

1 AGREEMENT

2 **29737**

3 THIS AGREEMENT is made and entered, in duplicate, as of August 1, 2006
4 for reference purposes only, pursuant to Resolution No. RES-06-0076 adopted by the City
5 Council of the City of Long Beach at its meeting on August 1, 2006, by and between
6 MCNEILUS TRUCK AND MANUFACTURING, INC. ("Contractor"), a Minnesota
7 corporation, located at 401 North Pepper, Colton, California 92324-1588 and the CITY OF
8 LONG BEACH ("City"), a municipal corporation.

9 WHEREAS, Section 1802 of the Long Beach City Charter permits the City
10 to make purchases under the purchasing contracts of other governmental agencies when
11 authorized to do so by a resolution; and

12 WHEREAS, the City desires to purchase three 20-yard rear loaders and six
13 28-yard automated side loaders; and

14 WHEREAS, the Long Beach Unified School District (the "District") has a
15 contract for the purchase of these vehicles, Purchase Order No. P928189 ("District
16 Purchase Order"); and

17 WHEREAS, Resolution No. RES-06-0076 authorizes the City Purchasing
18 Agent to purchase this equipment from Contractor by virtue of the District Purchase Order;

19 NOW, THEREFORE, in consideration of the terms and conditions contained
20 in this Agreement, the parties agree as follows:

21 1. The District Purchase Order with Contractor is incorporated by this
22 reference as if fully set forth, and the same terms and conditions contained in the District
23 Purchase Order shall be applicable here except as follows:

24 a. Wherever the District Purchase Order refers to the District, it shall be
25 deemed to refer to the City of Long Beach;

26 b. Contractor shall sell, furnish and deliver to the City equipment of
27 substantially the same type and kind purchased by the Long Beach Unified School District
28 and on the same terms and conditions offered to the Long Beach Unified School District,
except as modified by Exhibit "A" attached to and incorporated in this Agreement, for an

Robert E. Shannon
City Attorney of Long Beach
333 West Ocean Boulevard
Long Beach, California, 90802-4664
Telephone (562) 570-2200

Robert E. Shannon
City Attorney of Long Beach
333 West Ocean Boulevard
Long Beach, California 90802-4664
Telephone (562) 570-2200

1 amount not to exceed \$2,059,257 plus tax plus a 10% contingency. To the extent that the
2 District Purchase Order and this Agreement are inconsistent, the following priority shall
3 govern: (1) this Agreement and (2) the District Purchase Order.

4 c. Payment for the equipment purchased from Contractor by City shall be
5 made by the City on delivery to and acceptance of the equipment by the City and submittal
6 of an invoice to the City. Payment is due thirty (30) days after the date of the invoice.

7 d. All warranties shall accrue to the City of Long Beach.

8 e. The parties may, by mutual agreement, amend this Agreement with the
9 approval of the City's City Council.

10 2. Neither this Agreement nor any money that becomes due to Contractor
11 under this Agreement may be assigned by Contractor without the prior written consent of
12 the City manager or his designee.

13 3. Any notice given under this Agreement shall be in writing and personally
14 delivered or deposited in the U.S. Postal Service, return receipt, and shall be delivered or
15 mailed to Contractor at the relevant address first stated above, and to the City at 333 West
16 Ocean Boulevard, Long Beach, California 90802 Attn: City Manager. Notice shall be
17 deemed given three days after deposit in the mail.

18 4. The terms appearing on the back of District's Purchase Order are
19 incorporated in this Agreement. Contractor is called "Vendor" in the District's Purchase

Robert E. Shannon
City Attorney of Long Beach
333 West Ocean Boulevard
Long Beach, California 90802-4664
Telephone (562) 570-2200

1 costs and expenses, including reasonable attorney's fees.

2 IN WITNESS WHEREOF, the parties have caused this document to be duly
3 executed with all formalities required by law as of the date first stated above.

4 MCNEILUS TRUCK AND MANUFACTURING,
INC., a Minnesota corporation

5 August 17, 2006 By Michael J. Wuest
6 President

7 August 17, 2006 By Michael J. Wuest
(Type or Print Name)

8 August 17, 2006 By JoAnn L. Scherger
Secretary

9 August 17, 2006 By JoAnn L. Scherger
(Type or Print Name)

10 "Contractor"

11 CITY OF LONG BEACH, a municipal corporation

12 Aug 25, 2006 By [Signature]
13 City Manager

14 "City"

15 This Agreement is approved as to form on 8/22, 2006.

16 ROBERT E. SHANNON, City Attorney

17 By [Signature]
18 Senior Deputy

EXHIBIT “A”

Quote No: 21456

To: City of Long Beach
2600 Temple Avenue
Long Beach, CA 90806

Attn: John Seevers

Date: April 17, 2006

McNeilus Companies is pleased to present you with the following quotation:

McNEILUS 28 YARD STREET FORCE AUTOMATED SIDE LOADER

BODY SPECIFICATIONS

- Body Floor: 10 Gauge AR200
- Body Roof: 10 Gauge AR200
- Body Side Walls, First Section Street Side: 1/8" AR500
- Body Side Walls, All Other Sections: 10 Gauge AR200
- Body Longitudinal: 10 Gauge GRD 50 high strength Steel (formed channel) w/1/4" Doubler Plates at Hinge and lift stress points
- Front Body Longitudinal: 3/8" A500 GRD B Tubing
- Bolt On Fender: 14 Gauge A569 Formed Steel
- Hopper Transition to Main Body, 1/4" AR400 Liner

HOPPER SPECIFICATIONS

- Hopper Sides, Lower Left Side and Right Side: 3/16" AR400
- Hopper Side, Upper Left: 10 Gauge GRD 50 high strength Steel
- Hopper Floor Wear Area: 1/4" AR400, Plus 1/4" AR400 Liner
- Hopper Assist Panel: 3/16" AR200
- Hopper Ribs: 10 Gauge GRD 50 high strength Steel
- Floor Support: 1/8" A500 GRD B Tubing, 10 Gauge GRD 50 Formed Steel

ARM SPECIFICATIONS

- Inner Arm: 5" x 7" x 1/4" Tubing
- Outer Arm: 1/4" GRD 50 high strength Steel Web, 1/2" GRD 50 high strength Steel Outer Plate
- Lifter Link Arm: 3/4" GRD 50 high strength Steel welded structure
- Arm Mounting Bracket: 1/2" GRD 50 high strength Steel (bolted to chassis)
- Grabber: 2-piece bolt on welded structure—Inner Section 3/8" x 1/4" GRD 50 high strength steel, Outer Section 3/8" T-1

TAILGATE SPECIFICATIONS

- Side and Rear Walls: 1/8" AR500
- Post and Bolsters (Header and Footer): 10 Gauge A607 GRD 50 high strength Steel

PACKER SPECIFICATIONS

- Packing Face: 1/4" AR200
- Sides: 1/4" A572 GRD 50 high strength Steel
- Follower Panels (2 sections): 10 Gauge A569 GRD 50 high strength Steel
- Support Frame: 3/16" A500 GRD B Tubing

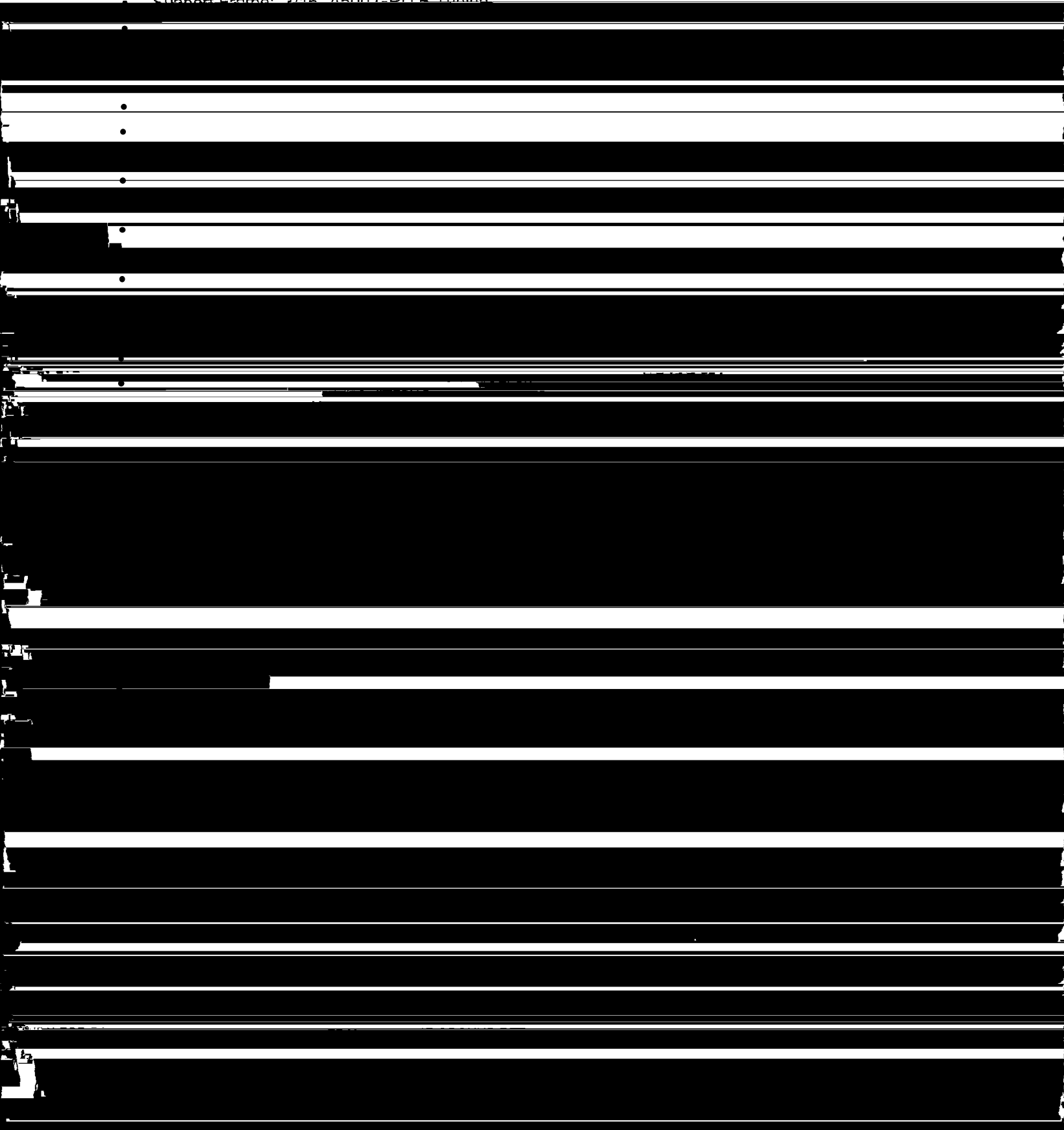

PRICE: \$238,410.00 Price does not include FET See Attached Body Specs

Options Included in Price:

- 1 Hopper Work Light
- Arm Work Light
- Cameras, Dual Intec MCN-2N
- Decals- "Frequent Stops" and "Backup"
- Body Paint Blue FLNA 50396
- Drip Pan Under Bumper
- Plastic Spillshield on Arm
- Pall Return Line Filter
- Auto Load
- Filter Bypass Monitor in Cab
- AVL System
- SI Axle Scales 3 Point Installed in CA
- Mudflaps (Front of Tandem)
- Packer Assist Panel Lightweight
- Roadway Sign Brackets Only
- 17 Gallon Spill Kit
- Peterson Smartlight System
- Plastic Shovel
- Outside Controls
- 3 Year Packer Warranty
- Cummins 5 Year 150,000 Mile Warranty
- Allison 5 Year Warranty

Prepared for:
Barry Torgerson
McNeilus Companies
401 North Pepper
PO Box 1588
Colton, CA 92324
Phone: 909-370-2100
Cell: 909-374-2876
E-Mail:
btorgerson@mcneilusco.com

Prepared by:
Ron Creighton
LOS ANGELES FREIGHTLINER
- WESTERN STAR
2429 S. PECK ROAD
WHITTIER, CA 90601
Phone: 562-447-1200
Cell: 562-755-6108
E-Mail:
RCreighton@lafreightliner.com

A proposal for
McNeilus Companies

Prepared by
LOS ANGELES FREIGHTLINER - WESTERN STAR
Ron Creighton

April 11, 2006

CONDOR LOW CAB FORWARD CHASSIS

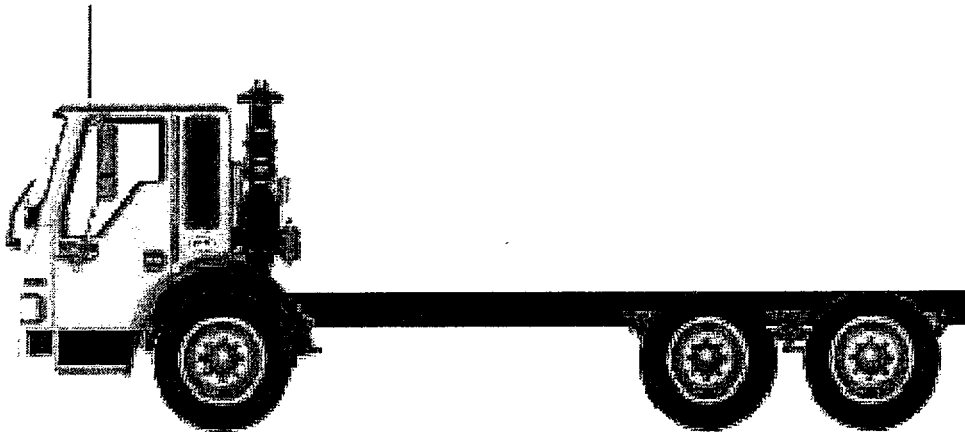

Prepared for:
Barry Torgerson
McNeilus Companies
401 North Pepper
PO Box 1588
Colton, CA 92324
Phone: 909-370-2100
Cell: 909-374-2876
E-Mail:
btorgerson@mcneilusco.com

Prepared by:
Ron Creighton
LOS ANGELES FREIGHTLINER
- WESTERN STAR
2429 S. PECK ROAD
WHITTIER, CA 90601
Phone: 562-447-1200
Cell: 562-755-6108
E-Mail:
RCreighton@lafreightliner.com

S P E C I F I C A T I O N P R O P O S A L

Price Level	Description	Weight Front	Weight Rear
-------------	-------------	-----------------	----------------

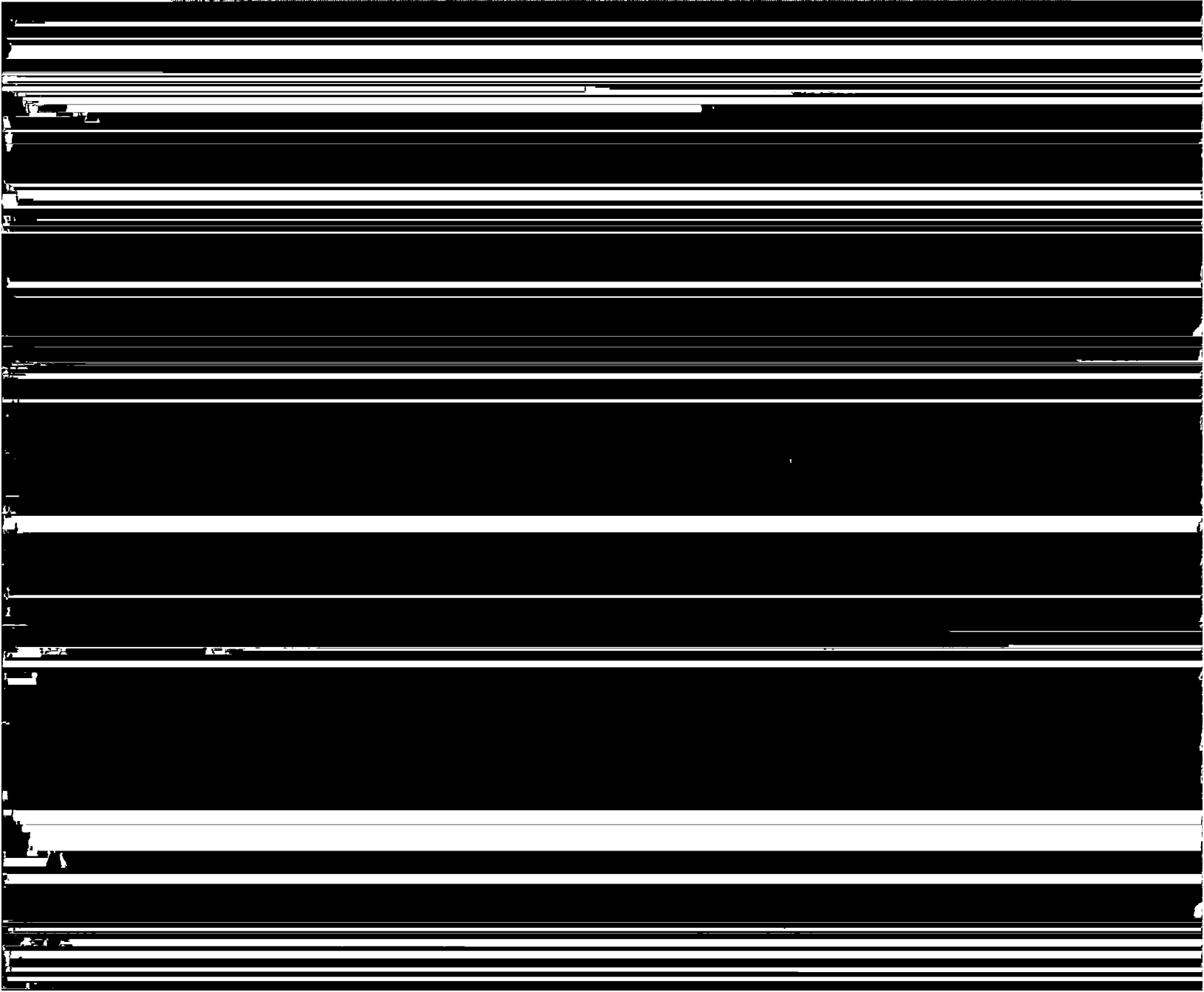

Prepared for:
 Barry Torgerson
 McNeilus Companies
 401 North Pepper
 PO Box 1588
 Colton, CA 92324
 Phone: 909-370-2100
 Cell: 909-374-2876
 E-Mail:
 btorgerson@mcneilusco.com

Prepared by:
 Ron Creighton
 LOS ANGELES FREIGHTLINER
 - WESTERN STAR
 2429 S. PECK ROAD
 WHITTIER, CA 90601
 Phone: 562-447-1200
 Cell: 562-755-6108
 E-Mail:
 RCreighton@lafreightliner.com

Description	Weight Front	Weight Rear
Engine		
* CUM C 8.3G+ 280 HP @ 2400 RPM ELEC N-GAS850 LB/FT @ 1400 RPM		
Engine Equipment		
* 2004 EPA/CARB EMISSION CERTIFICATION ENGINE MOUNTED OIL CHECK AND FILL		
* ONE PIECE VALVE COVER VERTICAL SNORKEL AND DONALDSON HIGH CAPACITY AIR CLEANER MOUNTED HORIZONTALLY BACK OF CAB		
STATIONARY VERTICAL AIR INTAKE SNORKEL, LOCATED RH SIDE OUTBOARD		
DONALDSON ONE-STAGE AIR CLEANER WITH SY- KLONE SERIES 9000 PRECLEANER	15	
AIR INTAKE PIPING - CLEANER TO ENGINE PLAIN BONNET AIR INTAKE HOOD/CAP		
* LN 12V 200 AMP 4863 ALTERNATOR WITH AC TAPS (3) ALLIANCE 1231 GROUP 31 12V MF 3300 CCA THREADED STUD BATTERIES	30	30
* ALUM BATT BOX FRAME MTD RH, SHORT SIDE TO RAIL		

Prepared for:
 Barry Torgerson
 McNeilus Companies
 401 North Pepper
 PO Box 1588
 Colton, CA 92324
 Phone: 909-370-2100
 Cell: 909-374-2876
 E-Mail:
 btorgerson@mcneilusco.com

Prepared by:
 Ron Creighton
 LOS ANGELES FREIGHTLINER
 - WESTERN STAR
 2429 S. PECK ROAD
 WHITTIER, CA 90601
 Phone: 562-447-1200
 Cell: 562-755-6108
 E-Mail:
 RCreighton@lafreightliner.com

Description	Weight Front	Weight Rear
FLEXIBLE STAINLESS STEEL EXHAUST PIPING		
STANDARD EXHAUST SYSTEM LENGTH		
SINGLE VERTICAL MUFFLER		
* STAINLESS STEEL MUFFLER INLET ELBOW(S) WITH CHROME STACK(S)		
VERTICAL TAILPIPE, LH		
STAINLESS STEEL AFTERTREATMENT DEVICE/MUFFLER/TAILPIPE SHIELD		
CHROME EXHAUST RAIN CAP		
HORTON DRIVEMASTER ON/OFF FAN DRIVE		
AUTOMATIC FAN CONTROL-WITHOUT DASH SWITCH		
* CUMMINS SUPPLIED FLEETGUARD COALESCING FILTER (LOW PRESSURE) CNG		
* FLEETGUARD LF-3000 COMBINATION FULL FLOW/BYPASS OIL FILTER - ENGINE MOUNTED		
* FLEETGUARD COOLANT FILTER, PLAIN		
1164 SQUARE INCH COPPER/BRASS RADIATOR		
REMOTE MOUNTED SURGE TANK		
ANTIFREEZE TO -34F, ETHYLENE GLYCOL PRE-CHARGED SCA HEAVY DUTY COOLANT		
GATES BLUE STRIPE COOLANT HOSES		
CONSTANT TENSION HOSE CLAMPS FOR COOLANT HOSES		
HEAVY DUTY CHARGE AIR COOLER		
HEAVY-DUTY RADIATOR MOUNTING		
RADIATOR DRAINCOCK		
* 1350 ADAPTER FLANGE FOR FRONT PTO PROVISION		
ALUMINUM FLYWHEEL HOUSING		
* NO AIR INTAKE WARMER		
* DELCO 12V 37MT STARTER; SEALED MOTOR AND SOLENOID		
FLYWHEEL HOUSING REAR ENGINE SUPPORT		
Transmission		
ALLISON 4500 RDS AUTOMATIC TRANSMISSION WITH PTO PROVISION	240	70
Transmission Equipment		
WTEC CALIBRATION - 5 SPEED RDS (PACKAGE 142)		
VEHICLE INTERFACE WIRING FOR REFUSE BODY BUILDER CONNECTOR, BACK OF CAB		



Prepared for:
Barry Torgerson
McNeilus Companies

Prepared by:
Ron Creighton
LOS ANGELES FREIGHTLINER

Prepared for:
 Barry Torgerson
 McNeilus Companies
 401 North Pepper
 PO Box 1588
 Colton, CA 92324
 Phone: 909-370-2100
 Cell: 909-374-2876
 E-Mail:
 btorgerson@mcneilusco.com

Prepared by:
 Ron Creighton
 LOS ANGELES FREIGHTLINER
 - WESTERN STAR
 2429 S. PECK ROAD
 WHITTIER, CA 90601
 Phone: 562-447-1200
 Cell: 562-755-6108
 E-Mail:
 RCreighton@lafreightliner.com

Description	Weight Front	Weight Rear
INTERAXLE AND/OR DIFFERENTIAL LOCKOUT WITH INDICATOR LIGHT		
CASTROL TRANSYND SYNTHETIC AUTOMATIC TRANSMISSION OIL AND MOBIL SYNTHETIC 75W-90W ALL AXLES		
MERITOR 16.5X8.62 Q+ CAST SPIDER CAM REAR BRAKES, DOUBLE ANCHOR, FABRICATED SHOES		120
REFUSE SEVERE SERVICE, NON-ASBESTOS REAR LINING		
BRAKE CAMS AND CHAMBERS ON FORWARD SIDE OF DRIVE AXLE(S)		
GUNITE CAST IRON REAR BRAKE DRUMS		
CHICAGO RAWHIDE SCOTSEAL REAR OIL SEALS		
MGM TR-T LONGSTROKE 2-DRIVE AXLES SPRING PARKING CHAMBERS		
HALDEX AUTOMATIC REAR SLACK ADJUSTERS		

Rear Suspension

TUFTRAC 40,000# REAR SPRING SUSPENSION
 TUFTRAC LOW RIDE HEIGHT
 AXLE CLAMPING GROUP
 54" AXLE SPACING
 FORE/AFT AND TRANSVERSE CONTROL RODS
 REAR SHOCK ABSORBERS - TWO AXLES (TANDEM)

Brake System

WABCO 4S/4M ABS WITHOUT TRACTION CONTROL ENHANCEMENT
 REINFORCED NYLON, FABRIC BRAID AND WIRE BRAID CHASSIS AIR LINES
 FIBER BRAID HOSE FRONT SERVICE BRAKE
 FIBER BRAID HOSE REAR SERVICE BRAKE
 FIBER BRAID PARKING BRAKE HOSE
 BENDIX BRAKE VALVES WHERE POSSIBLE
 STD U.S. FRONT BRAKE VALVE
 RELAY VALVE WITH 5-8 PSI CRACK PRESSURE NO REAR PROPORTIONING VALVE
 BW AD-9 BRAKE LINE AIR DRYER WITH HEATER
 ALUMINUM AIR BRAKE RESERVOIRS
 (1) 700 CU. IN. AUXILIARY AIR TANK, INLET CHECK VALVE
 PULL CABLES ON ALL AIR RESERVOIR(S)

Trailer Connections



Prepared for:
 Barry Torgerson
 McNeilus Companies
 401 North Pepper
 PO Box 1588
 Colton, CA 92324
 Phone: 909-370-2100
 Cell: 909-374-2876
 E-Mail:
 btorgerson@mcneilusco.com

Prepared by:
 Ron Creighton
 LOS ANGELES FREIGHTLINER
 - WESTERN STAR
 2429 S. PECK ROAD
 WHITTIER, CA 90601
 Phone: 562-447-1200
 Cell: 562-755-6108
 E-Mail:
 RCreighton@lafreightliner.com

Description	Weight Front	Weight Rear
AIR CONNECTIONS AND ANCHOR COUPLINGS TO FRONT OF FRAME FOR TOWING	10	
PLUMBING FOR AUXILIARY AIR TANK WITH PROTECTED SUPPLY		
OMISSION OF STANDARD CABLE		
Wheelbase & Frame		
5725MM (225") WHEELBASE		
* 7/16" X 3-11/16" X 11-1/8" STEEL FRAME (11.11MM X 282.6MM/.437" X 11.13")110KSI	390	170
1425MM (56") REAR FRAME OVERHANG		
FRAME OVERHANG RANGE: 51" TO 60"	-10	50
1" BOLT-ON FRONT FRAME SPACER		
UNDERSLUNG CROSSMEMBER		
SQUARE END OF FRAME		
HEAVY DUTY FRONT CLOSING CROSSMEMBER		
STANDARD CROSSMEMBER BACK OF TRANSMISSION		
STANDARD MIDSHIP #1 CROSSMEMBER(S)		
STANDARD REARMOST CROSSMEMBER		
HEAVY DUTY SUSPENSION CROSSMEMBER		
Chassis Equipment		
NO LH OR RH BACK OF CAB ACCESS		
8" PAINTED STEEL BUMPER - HD 1/4"		
FRONT TOW HOOKS - FRAME MOUNTED		
BUMPER MOUNTING FOR SINGLE LICENSE PLATE		
NO MUDFLAP BRACKETS		
NO REAR MUDFLAP		
FRONT ANTI-SPRAY FENDER MOUNTED MUDFLAPS	15	
CLEAR FRAME RAILS (EXCEPT FUEL TANKS AND BATTERY BOX) OUTBOARD BOTH RAILS BACK OF CAB TO REAR SUSPENSION		
HUCK-SPIN ROUND COLLAR CHASSIS FASTENERS		
Fuel Tanks		
* NO RH FUEL TANK		
* 119 GALLON / 450 LITER CHART LNG FUEL TANK		

Prepared for:
 Barry Torgerson
 McNeilus Companies
 401 North Pepper
 PO Box 1588
 Colton, CA 92324
 Phone: 909-370-2100
 Cell: 909-374-2876
 E-Mail:
 btorgerson@mcneilusco.com

Prepared by:
 Ron Creighton
 LOS ANGELES FREIGHTLINER
 - WESTERN STAR
 2429 S. PECK ROAD
 WHITTIER, CA 90601
 Phone: 562-447-1200
 Cell: 562-755-6108
 E-Mail:
 RCreighton@lafreightliner.com

	Description	Weight Front	Weight Rear
	PLAIN STEP FINISH		
*	CNG/LNG PARKER HANNIFIN TYPE LH FILLER RECEPTACLE AND DUST CAP		
*	NO FUEL TANK DRAIN VALVES		
*	MVE LNG FUEL HEATER		
*	FUEL LINES WITH NATURAL GAS CHECK VALVE, REGULATOR AND SHUTOFF SOLENOID WITH MACROTECH VENT FILL PIPE CON. ROUTED TO UPRIGHT		
*	CUSTOM FUEL HOSE		
*	STAINLESS STEEL HIGH PRESSURE FUEL HOSE		
*	NO FUEL LINE INSULATION		
Tires			
	315/80R22.5 20 PLY RADIAL FRONT TIRES		
	MICHELIN XZU-S 315/80R22.5 20 PLY RADIAL FRONT TIRES	78	
	315/80R22.5 20 PLY RADIAL REAR TIRES		
	MICHELIN XZU-S 315/80R22.5 20 PLY RADIAL REAR TIRES		312
*	MICHELIN XZU-S 315/80R22.5 20 PLY RADIAL SPARE TIRE		
*	MICHELIN XZU-S 315/80R22.5 20 PLY RADIAL ADDITIONAL SPARE TIRE		
Hubs			
	WEBB IRON FRONT HUBS		
	CONMET ALUMINUM REAR HUBS		
Wheels			
	ALCOA 893630 22.5X9.00 10-HUB PILOT 3.12 INSET 10-HAND ALUMINUM DISC FRONT WHEELS	-58	

Prepared for:
 Barry Torgerson
 McNeilus Companies
 401 North Pepper
 PO Box 1588
 Colton, CA 92324
 Phone: 909-370-2100
 Cell: 909-374-2876
 E-Mail:
 btorgerson@mcneilusco.com

Prepared by:
 Ron Creighton
 LOS ANGELES FREIGHTLINER
 - WESTERN STAR
 2429 S. PECK ROAD
 WHITTIER, CA 90601
 Phone: 562-447-1200
 Cell: 562-755-6108
 E-Mail:
 RCreighton@lafreightliner.com

Description	Weight Front	Weight Rear
Cab Exterior		
68" BBC LOW CAB FORWARD ALUMINUM CAB		
RH CAB DOOR WITH 70 DEGREE DOOR STRAP		
LH CAB DOOR WITH 70 DEGREE DOOR STRAP		
RUBBER CAB MOUNTS		
HYDRAULIC CAB TILT MECHANISM WITH MANUAL PUMP, LOCATED RH SIDE BOC OVER FENDER		
HYDRAULIC CAB LATCH		
NONREMOVABLE BUGSCREEN MOUNTED BEHIND GRILLE		
BLACK POLYURETHANE QUARTER FENDER BEHIND FRONT WHEEL		
2" FENDER EXTENSIONS		
INTERIOR AND EXTERIOR GRAB HANDLES FOR CAB ACCESS ON DRIVER AND PASSENGER SIDES		
TWO GRAB HANDLES MOUNTED ON FRONT OF CAB BELOW WINDSHIELD		
PAINTED CAB MOUNTED GRILLE WITH QUICK RELEASE LATCHES		
AMERICAN LAFRANCE CONDOR NAME PLATES		
TUNNEL/FIREWALL LINER		
HADLEY ROUND AIR HORN, SINGLE BASE; 2 TRUMPETS DUAL TONE 12.5/10.25" MOUNTED BEHIND GRILLE	8	
SINGLE ELECTRIC HORN		
ALL LOCKS KEYED THE SAME		
DUAL RECTANGULAR HALOGEN HEADLIGHTS		
(5) AMBER MARKER LIGHTS		
DAYTIME RUNNING LIGHTS		
WIRING HARNESS ONLY TO END OF FRAME FOR STOP, TAIL, TURN SIGNALS		
STANDARD FRONT WITH SURFACE MOUNTED SIDE AUXILIARY TURN SIGNAL		
DUAL MOLDED-IN COLOR WEST COAST MIRRORS		
DOOR MOUNTED MIRRORS		
LH/RH 8" MOLDED-IN COLOR CONVEX MIRRORS MOUNTED UNDER PRIMARY MIRRORS		
LH DOWN VIEW MIRROR		
STANDARD SIDE/REAR REFLECTORS		
FIXED CAB MOUNTED STEPS RH/LH FOR CAB ENTRY		



Prepared for:
Barry Torgerson
McNeilus Companies
401 North Pepper
PO Box 1588
Colton, CA 92324
Phone: 909-370-2100
Cell: 909-374-2876
E-Mail:
btorgerson@mcneilusco.com

Prepared by:
Ron Creighton
LOS ANGELES FREIGHTLINER
- WESTERN STAR
2429 S. PECK ROAD
WHITTIER, CA 90601
Phone: 562-447-1200
Cell: 562-755-6108
E-Mail:
RCreighton@lafreightliner.com

Description	Weight Front	Weight Rear
20"X36" TINTED CENTER AND (2) 20"X15" TINTED OUTBOARD REAR WINDOWS		20
TINTED DOOR GLASS		
RH AND LH ELECTRIC POWERED WINDOWS		4
8"X34" TINTED VERTICAL UPPER SIDE WINDOWS LH AND RH		6
TINTED WINDSHIELD		
ONE GALLON WINDSHIELD WASHER RESERVOIR LOCATED TO INBOARD SIDE OF UPRIGHT		

Cab Interior

Prepared for:
 Barry Torgerson
 McNeilus Companies
 401 North Pepper
 PO Box 1588
 Colton, CA 92324
 Phone: 909-370-2100
 Cell: 909-374-2876
 E-Mail:
 btorgerson@mcneliusco.com

Prepared by:
 Ron Creighton
 LOS ANGELES FREIGHTLINER
 - WESTERN STAR
 2429 S. PECK ROAD
 WHITTIER, CA 90601
 Phone: 562-447-1200
 Cell: 562-755-6108
 E-Mail:
 RCreighton@lafreightliner.com

Description	Weight Front	Weight Rear
DOOR ACTIVATED CENTER DOME LIGHT WITH LIGHT MOUNTED SWITCH		
CAB DOOR LATCHES WITH MANUAL DOOR LOCKS		
(1) 12V POWER SUPPLY IN DASH		
TRIANGULAR REFLECTORS WITHOUT FLARES, MOUNTED BEHIND DRIVER ON CAB BACKWALL	10	
NATIONAL 2000 SERIES MID BACK DRIVER SEAT WITH ACTIVE AIR LUMBAR SUPPORT		
NATIONAL 2000 SERIES MID BACK NON SUSPENSION PASSENGER SEAT		
CORDURA PLUS CLOTH DRIVER SEAT COVER		
CORDURA PLUS CLOTH PASSENGER SEAT COVER		
3 POINT ADJUSTABLE D-RING RETRACTOR DRIVER AND PASSENGER SEAT BELTS		
ADJUSTABLE TILT AND TELESCOPING STEERING COLUMN		
2-SPOKE 18" (450MM) BLACK STEERING WHEEL(S)		
DRIVER/PASSENGER INTERIOR SUN VISORS		

Instruments & Controls

CONDOR STANDARD GAUGE PACKAGE		
BLACK GAUGE BEZELS		
INTEGRAL GAUGES MOUNTED IN INSTRUMENT PANEL CLUSTER		
GRAY CENTER INSTRUMENT PANEL		
LOW AIR PRESSURE LIGHT AND BUZZER		
2" PRIMARY AND SECONDARY AIR PRESSURE GAUGES		
AIR RESTRICTION GAUGE, AIR CLEANER MOUNTED		
ECCO MODEL 917 AUTOMATIC SELF-ADJUSTING BACKUP ALARM WITH REVERSE MOTION SENSOR		2
KEY OPERATED IGNITION SWITCH AND INTEGRAL START POSITION; 4 POSITION OFF/RUN/START/ACCESSORY		
INTEGRATED SPEEDOMETER MESSAGE CENTER LCD DISPLAY, DATA LINKED		
DIAGNOSTIC INTERFACE CONNECTOR, 6 PIN, SAE J1587/1708, LOCATED BELOW DASH		
ELECTRIC FUEL GAUGE WITH MECHANICAL PRESSURE GAUGE AT TANK FOR LNG		
ELECTRICAL ENGINE COOLANT TEMPERATURE GAUGE		
2" TRANSMISSION OIL TEMPERATURE GAUGE		



Prepared for:
Barry Torgerson
McNeilus Companies
401 North Pepper
PO Box 1588
Colton, CA 92324
Phone: 909-370-2100
Cell: 909-374-2876

Prepared by:
Ron Creighton
LOS ANGELES FREIGHTLINER
- WESTERN STAR
2429 S. PECK ROAD
WHITTIER, CA 90601
Phone: 562-447-1200
Cell: 562-755-6108
E-Mail:

Wheelbase (545)

5725MM (225") WHEEL BASE

Prepared for:
Barry Torgerson
McNeilus Companies
401 North Pepper
PO Box 1588

Prepared by:
Ron Creighton
LOS ANGELES FREIGHTLINER
- WESTERN STAR
2429 S. PECK ROAD

Prepared for:
Barry Torgerson
McNeilus Companies
401 North Pepper
PO Box 1588
Colton, CA 92324
Phone: 909-370-2100
Cell: 909-374-2876
E-Mail:
btorgerson@mcneilusco.com

Prepared by:
Ron Creighton
LOS ANGELES FREIGHTLINER
- WESTERN STAR
2429 S. PECK ROAD
WHITTIER, CA 90601
Phone: 562-447-1200
Cell: 562-755-6108
E-Mail:
RCreighton@lafreightliner.com

DIMENSIONS

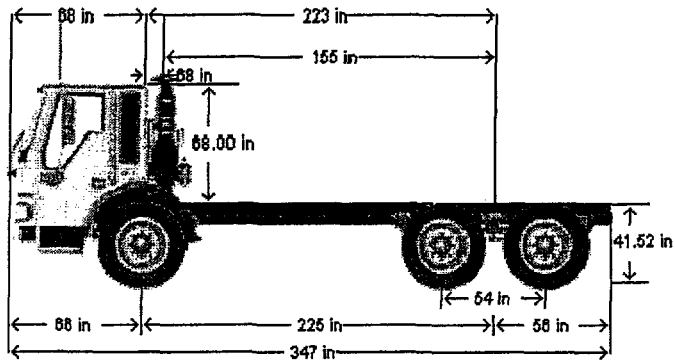

VEHICLE SPECIFICATIONS SUMMARY - DIMENSIONS

Model.....

FTLC

Prepared for:
 Barry Torgerson
 McNeilus Companies
 401 North Pepper
 PO Box 1588
 Colton, CA 92324
 Phone: 909-370-2100
 Cell: 909-374-2876
 E-Mail:
 btorgerson@mcneilusco.com

Prepared by:
 Ron Creighton
 LOS ANGELES FREIGHTLINER
 - WESTERN STAR
 2429 S. PECK ROAD
 WHITTIER, CA 90601
 Phone: 562-447-1200
 Cell: 562-755-6108
 E-Mail:
 RCreighton@lafreightliner.com

Exhaust System (016)..... SINGLE VERTICAL EXHAUST WITH PAINTED STACK LEFT SIDE

TABLE SUMMARY - DIMENSIONS

Dimension	Inches
Bumper to Back of Cab (BBC)	67.9
Bumper to Centerline of Front Axle (BA)	65.7
Min. Cab to Body Clearance (CB)	2.0
Back of Cab to Centerline of Rear Axle(s) (CA)	222.8
Effective Back of Cab to Centerline of Rear Axle(s) (Effective CA)	154.8
Back of Cab Protrusions (Exhaust/Intake) (CP)	29.7
Back of Cab Protrusions (Side Extenders/Trim Tab) (CP)	0.0
Back of Cab Clearance (CL)	68.0
Back of Cab to End of Frame	278.8
Cab Height (CH)	68.0
Wheelbase (WB)	225.0
Frame Overhang (OH)	56.0
Overall Length (OAL)	346.7
Rear Axle Spacing	54.0
Unladen Frame Height at Centerline of Rear Axle	41.5



Prepared for:
Barry Torgerson
McNeilus Companies
401 North Pepper
PO Box 1588
Colton, CA 92324
Phone: 909-370-2100
Cell: 909-374-2876
E-Mail:
btorgerson@mcneilusco.com

Prepared by:
Ron Creighton
LOS ANGELES FREIGHTLINER
- WESTERN STAR
2429 S. PECK ROAD
WHITTIER, CA 90601
Phone: 562-447-1200
Cell: 562-755-6108
E-Mail:
RCreighton@lafreightliner.com

	Front	Rear 1	Rear 2
Axle Component Weight Ratings			
Axles	20000	20000	20000

Prepared for:
 Barry Torgerson
 McNeilus Companies
 401 North Pepper
 PO Box 1588
 Colton, CA 92324
 Phone: 909-370-2100
 Cell: 909-374-2876
 E-Mail:
 btorgerson@mcneilusco.com

Prepared by:
 Ron Creighton
 LOS ANGELES FREIGHTLINER
 - WESTERN STAR
 2429 S. PECK ROAD
 WHITTIER, CA 90601
 Phone: 562-447-1200
 Cell: 562-755-6108
 E-Mail:
 RCreighton@lafreightliner.com

FRAME RBM

VEHICLE SPECIFICATIONS SUMMARY - FRAME RBM

Wheelbase (545)..... 5725MM (225") WHEELBASE
 Frame Rails (546) 7/16" X 3-11/16" X 11-1/8" STEEL FRAME (11.11MM X 282.6MM/.437" X 11.13")110KSI(546)
 Yield Strength (psi) 110000
 Section Modulus (per rail) (cu in) 22.25
 RBM (per rail) (lbf-in) 2448000

TABLE SUMMARY - FRAME RBM

Item	Description / Value
------	---------------------

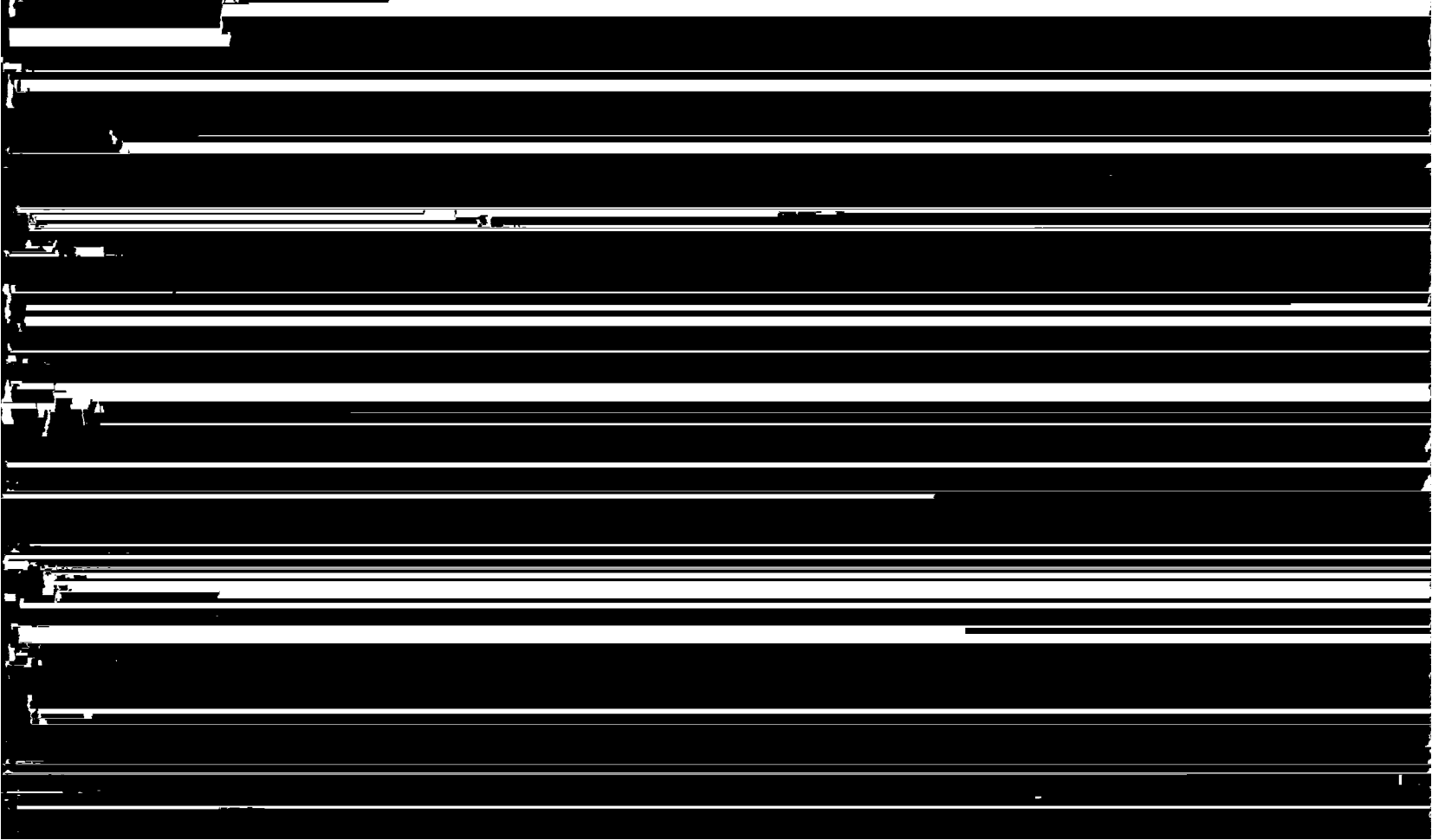

Customer: City of Long Beach X
 Freightliner Condor
 28 Yard Streetforce Autoreach

Requestor: B. Torgerson
 Preparer: J Bomgren 02/27/2006
 VIN:

Payload Total: 18,880 (674 lbs/yd)

Notes: Chassis weights supplied by Freightliner, LNG system included in chassis weight, Body weight actual from Key# 7391

Number of Axles: 3

Number of Rear Axles: 2

Auxillary Axles: Description	Distance	Weight	CG	Force
Pusher <input type="checkbox"/>	0.00	0.00	0.00	0.00
Tag <input type="checkbox"/>	0.00	0.00	0.00	0.00

Weight Summary

	Front Axle Tandem	Pusher	Rear Axle Tandem	Tag	Rear Group	Gross
Rating	20,000.0		40,000.0		40,000.0	
Bridge Law Max Weight	20,000.0		34,000.0		34,000.0	51,500.0
Chassis & Options Weight	9,819.0		6,591.0		6,591.0	16,410.0
Body & Options Weight	6,457.3		9,752.7		9,752.7	16,210.0
TARE Weight	16,276.3		16,343.7		16,343.7	32,620.0
Payload Weight	1,342.6		17,537.4		17,537.4	18,880.0
Total Weight	17,618.9	0.0	33,881.1	0.0	33,881.1	51,500.0
Weight %	34.2%	0.0%	65.8%	0.0%	65.8%	100.0%
Bridge Law Compliant?	Compliant		Compliant		Compliant	Compliant

Inches

- 225.00 A: Wheelbase
- 1.50 B: Back of Cab to Center of Front Axle
- 35.50 C: Back of Cab to Front of Body
- 54.00 D: Rear Tandem Spread
- 0.00 E: Center of Tandem or Center of Single Axle to Pusher Axle
- 0.00 F: Center of Tandem or Center of Single Axle to Tag Axle

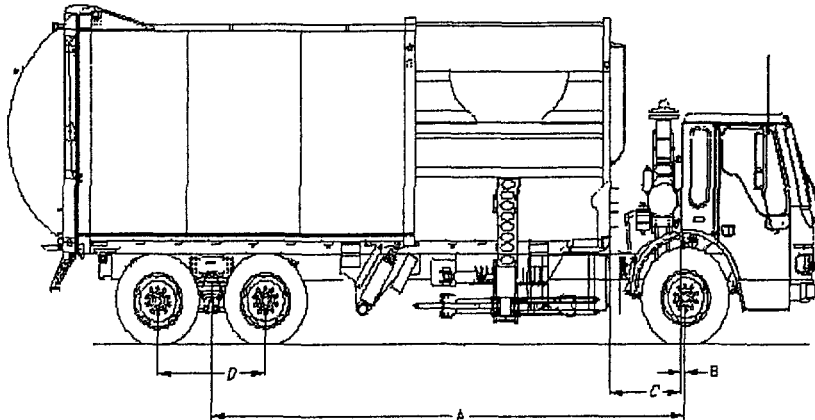

Note: Body and chassis weights are informational and subject to change. Payload configurations are approximate due to variations in payload content and consistency. Under no circumstance does McNeilus guarantee payload due to these variables.

	Inches	Feet		CG	Weight		Weight	CG
Outer Bridge:	252	21	Chassis Total:	90.4	16,410	Body:	16,210.00	98.37
Rear Inner Bridge:	54	5	Chassis Front:	0.0	9,819	Payload:	18,880.00	172.00
Front Tandem Bridge:	0	0	Chassis Rear:	225.0	6,591			
Rear Tandem Bridge:	54	5	Chassis Options Total:	0.0	0			
			Body Total:	135.4	16,210			
			Body Options Total:	37.0	0			
			Tag:	0.0	0			
			Pusher:	0.0	0			
			Payload:	209.0	18,880			
					51,500			

<u>Center of Gravity Summary</u>				
Front of Body Location from Front Axle			37.0	
Wheelbase			225.0	
Actual Back of Cab to Rear Axle/Tandem			223.5	
	<u>Chassis</u>	<u>Body</u>	<u>Payload</u>	<u>Body+Payload</u>
CG	90.4	98.4	172.0	138.0
Weight	16,410	16,210	18,880	35,090

<u>Auxiliary Axle Effects</u>	Front	Pusher	Rear	Tag	Total
Chassis	9,819	N/A	6,591	N/A	16,410
Body	6,457	N/A	9,753	N/A	16,210
Pusher Up	0	UP	0	UP	0
Tag Up	0	UP	0	UP	0
Tare Weight	16,276	UP	16,344	UP	32,620
Payload	1,343	N/A	17,537	N/A	18,880
Total Aux Axles Up	17,619	UP	33,881	UP	51,500
Pusher Down	0	0	0	N/A	0
Tag Down	0	N/A	0	0	0
Net Pusher Down	0	0	0	N/A	0
Net Tag Down	0	N/A	0	0	0
Total Aux Axles Down	17,619	0	33,881	0	51,500

Base Chassis Weight: 16,410

Chassis Options

Weight CG

Totals: 0.00 0.00

Total Chassis Weight with Options: 16,410

Maximum Axle Loading

Warning: Body and chassis weights are informational and subject to change. Payload configurations are approximate due to variations in payload content and consistency. Under no circumstance does McNeilus guarantee payload due to these variables.

	Bridge Law Compliant	Alternative Loading
Payload Weight:	18,880.00	25,465.00
(lbs/yard)	674	909
Pusher Force:	0.00	0.00
Tag Force:	0.00	0.00

<u>Axle Weights</u>	Front Axle Tandem	Pusher	Rear Axle Tandem	Tag	Rear Group	Gross
Axle Rating	20,000		40,000			
Bridge Law Compliant	17,619	0	33,881	0	33,881	51,500
Alternative Loading	18,087	0	39,998	0	39,998	58,085

Customer accepts this weight distribution and payload for this vehicle.

Signature: _____

Mr. John Seevers
City of Long Beach
2600 Temple Avenue
Long Beach, CA. 90806
Re: Pricing Differential & Deviations
from LBUSD Bid.

Side Loader

Engine & Equipment	\$37,228.00
Transmission & Equipment	\$217.00
Rear Axle & Equipment	\$3,600.00
Brake & Equipment	\$819.00
Frame	\$1,809.00
Fuel Tanks & Equipment	\$26,508.00
Tires & Wheels	\$8,971.00
Exterior Cab & Equipment	\$2,139.00
Interior Cab & Equipment	\$1,440.00
List Option Total	\$82,731.00
Net Option Total	\$62,048.25
Option Price Concession	<u>\$40,576.25</u>
	\$21,472.00

Best Regards,
Ron Creighton
Los Angeles Freightliner
2429 S. Peck Road
Whittier, CA. 90601
(562) 447-1515 office
(562) 695-2697 fax
(562) 755-6108 cellular

Quote No: 21455

To: City of Long Beach
2600 Temple Avenue
Long Beach, CA 90806

Attn: John Seevers

Date: April 17, 2006

McNeilus Companies is pleased to present you with the following quotation:

McNEILUS 20 YARD STANDARD REAR LOADER

BODY SPECIFICATIONS

- Floor: 3/16" AR200 (one piece)
- Floor Braces (width): 3/16" GRD 50 high strength Steel
- Floor Braces (length): C8 x 11.5" Channel
- Rear Floor Shelf: 5/16" AR200
- Side Wall, Rear Section: 1/8" AR500
- Side Wall, Front Section: 10 Gauge AR200
- Side Post: 3/16" GRD 50 high strength Steel
- Roof: 10 Gauge AR200
- Front: 3/16" GRD 50 high strength Steel (weldment)
- Access Door: 23 1/2" x 29 1/2" (located streetside)
- Body Bolsters: 10 Gauge GRD 50 high strength Steel

HOPPER SPECIFICATIONS

- 3.0 Cubic Yard Tailgate Capacity
- 55 1/2" Hopper Opening Height
- 80" Hopper Width
- 50" Hopper Tailgate Seal Height
- Hopper Braces and Support: 3/16" GRD 50 high strength Steel
- Upper Braces and Support: 11 Gauge GRD 50 high strength Steel (formed channel)
- Floor: 1/4" AR200
- Loading Edge: 1/4" GRD 50 high strength Steel
- Sides (bottom half): 3/16" AR200
- Sides (top half): 11 Gauge GRD 50 high strength Steel
- Tracks: 1/4" GRD 50 high strength Steel
- Wear Strips: 1/2" x 3" 1044 Steel

SLIDE SPECIFICATIONS

- Face: 3/16" GRD 50 high strength Steel
- Side Plates: 1/2" GRD 50 high strength Steel
- Braces: 3/16" GRD 50 high strength Steel
- Slide Shoes: A500 GRD B Rectangular Tubing with (2) 4" x 14" lower and (2) 4" x 14" upper high performance self-lubricating polymer pads

PACKING PANEL

- Face Plate: 1/4" AR200
- Cylinder Supports: 1/2" GRD 50 high strength steel plate
- Braces: 1/4" GRD 50 high strength Steel
- Ribs: 3/8" GRD 50 high strength Steel
- Packer Edge Strip: 3/4" GRD 50 high strength Steel
- Packer Bearing: 3 1/2" ID Bronze Bushings

EJECTOR

- Upper Vertical Face: 11 Gauge GRD 50 high strength Steel
- Lower Sloped Face: 10 Gauge A569 HR Steel
- Braces: C4 x 5.4 Structural Channel with 1/4" welded structure
- Slide Blocks: UHMW Plastic (4 pieces per side)
- Track Guides: 1/4" GRD 50 high strength Steel
- Gussets: 1/4" GRD 50 high strength Steel
- Ejector Cylinder center mounted with a 45 degree welded mount assembly with 1" sides and 3/8" base fully welded to floor of body

HYDRAULICS

- Pump Make/Model: Commercial Intertech (front mount model: P75, transmission mount model: P365)
- Pump Size: P75—1 3/4", P365—2" x 2"
- Pump Flow: 35 gpm @ 800 RPM
- Control Valves: Commercial Intertech VA35, MRV Setting—2700 psi
- Oil Reservoir: 17 yard and 20 yard—40 Gallons
25 yard and 32 yard—50 Gallons
- Filter: Parker 40 CN
- Suction Strainer: 100 mesh stainless steel with magnets

CYLINDERS

- Ejector Cylinder: 17 yard—6 x 3 stage x 71"
20 yard—6 x 3 stage x 88"
25 yard—7 x 4 stage x 119"
32 yard—8 x 5 stage x 163"
- Sweep Cylinder: 4" bore x 3" cylinder size x 23" stroke
- Slide Cylinder: 4 1/2" bore x 3 1/2" cylinder size x 32 1/2" stroke
- Tailgate Cylinder: 2.88" bore x 2 1/2" cylinder size x 38" stroke

HARDWARE

- Weather Pak Connector—Deutsch Connectors
- Aeroquip Hoses and Fittings

Continuation of Quote # 21455

- Hydra-Zorb and Stauff Clamps
- Rear lights, signal lights, and back-up lights are 4" Truk-Lite brand with Bowman brand fasteners

McNEILUS WARRANTIES

- Cylinders: 5 year limited warranty from date of delivery
- Hydraulic Pump and Valves: 2 years from date of delivery
- Packer Unit: 6 months from date of delivery

PAINTING

- Packer and components steel shot blasted prior to priming with high solids epoxy primer. Finish Coat Akzo Coating's Sikkens high solids acrylic urethane. Solid white standard.

PRICE: \$209,599.00 Price does not include FET See Attached Body Specs

Options Included in Price:

- 4 Hopper Work Lights
- Dual Bayne Tippers BTL 1110
- Container Tipper
- Decal- "This Truck Backs Up"
- Body Paint, Blue FLNA 50396
- Manuals and CDs
- Roadway Sign Brackets only
- Peterson Smartlight System
- RH Tailgate and Ejector Pneumatic Controls
- Cover for Hydraulic Lines
- Liners: Hopper
- Mudflaps (Front and Rear of Tandem)

Throttle Advance RH Side

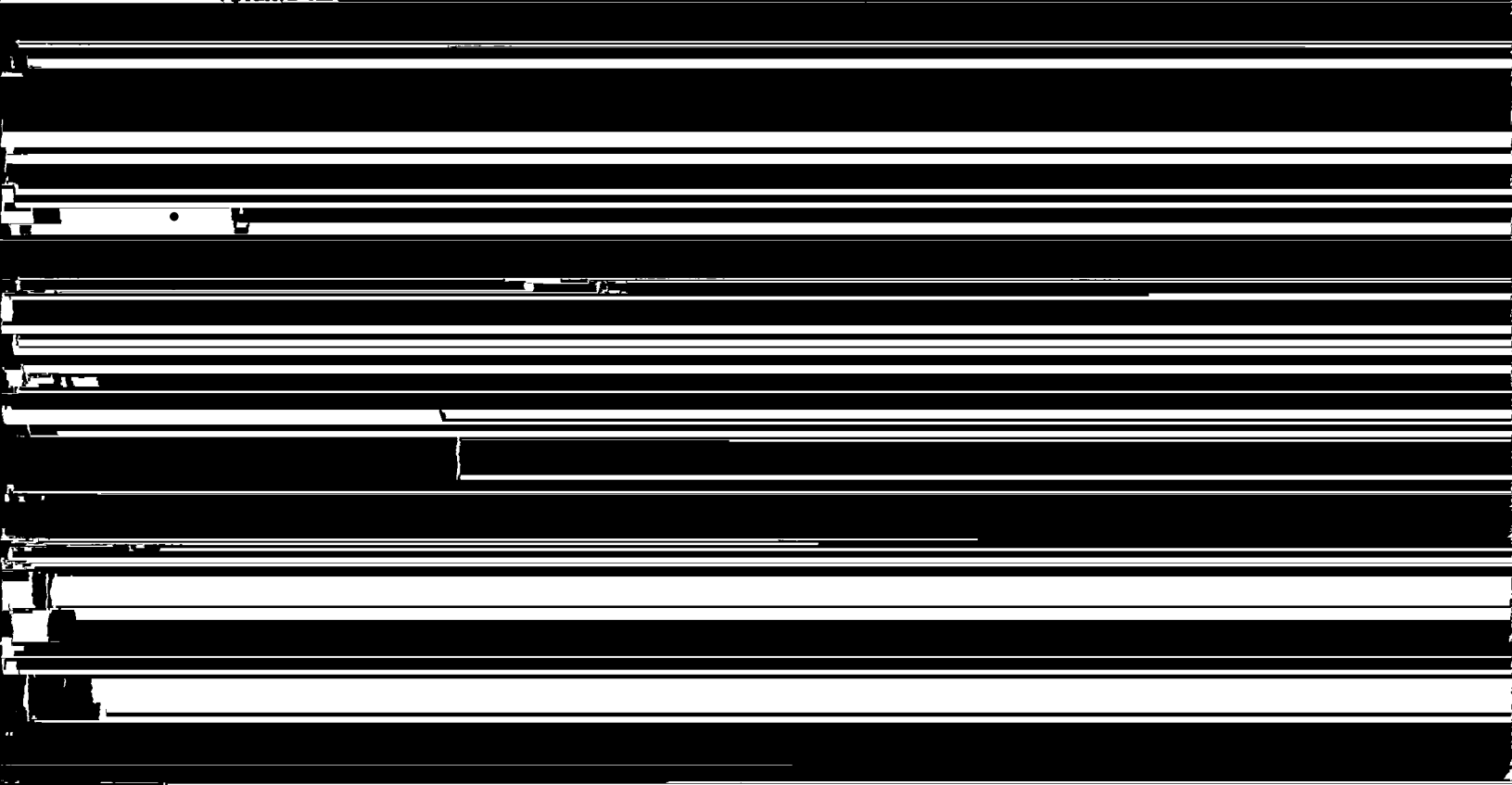

CHROME EXHAUST RAIN CAP
HORTON DRIVEMASTER ON/OFF FAN DRIVE
AUTOMATIC FAN CONTROL WITHOUT DASH SWITCH
* CUMMINS SUPPLIED FLEETGUARD COALESCING FILTER (LOW PRESSURE) CNG
* FLEETGUARD LF-3000 COMBINATION FULL FLOW/BYPASS OIL FILTER - ENGINE MOUNTED
* FLEETGUARD COOLANT FILTER, PLAIN
1164 SQUARE INCH COPPER/BRASS RADIATOR
REMOTE MOUNTED SURGE TANK
ANTIFREEZE TO -34F, ETHYLENE GLYCOL PRE-CHARGED SCA HEAVY DUTY COOLANT
GATES BLUE STRIPE COOLANT HOSES
CONSTANT TENSION HOSE CLAMPS FOR COOLANT HOSES

Prepared for:
Barry Torgerson
McNeilus Companies
401 North Pepper
PO Box 1588
Colton, CA 92324
Phone: 909-370-2100
Cell: 909-374-2876
E-Mail:
btorgerson@mcneilusco.com

Prepared by:
Ron Creighton
LOS ANGELES FREIGHTLINER
- WESTERN STAR
2429 S. PECK ROAD
WHITTIER, CA 90601
Phone: 562-447-1200
Cell: 562-755-6108
E-Mail:
RCreighton@lafreightliner.com

A proposal for
McNeilus Companies

Prepared by
LOS ANGELES FREIGHTLINER - WESTERN STAR
Ron Creighton

April 11, 2006

CONDOR LOW CAB FORWARD CHASSIS

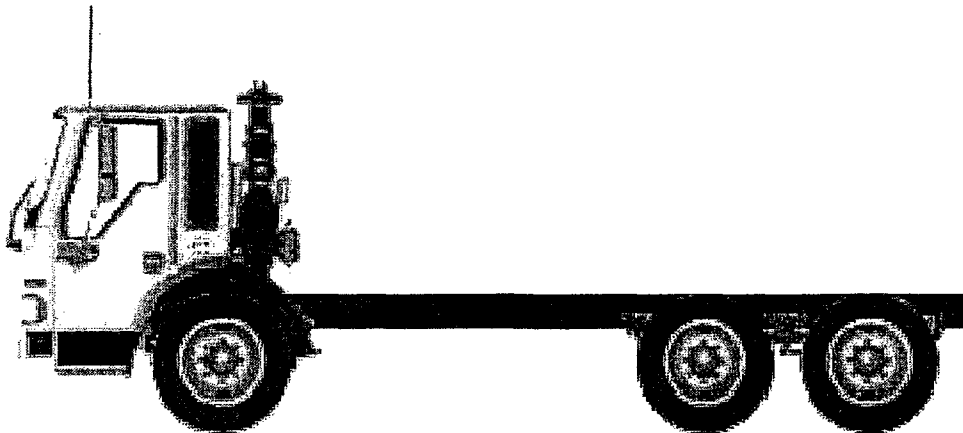

Prepared for:
Barry Torgerson
McNeilus Companies
401 North Pepper
PO Box 1588
Colton, CA 92324
Phone: 909-370-2100
Cell: 909-374-2876
E-Mail:
btorgerson@mcneilusco.com

Prepared by:
Ron Creighton
LOS ANGELES FREIGHTLINER
- WESTERN STAR
2429 S. PECK ROAD
WHITTIER, CA 90601
Phone: 562-447-1200
Cell: 562-755-6108
E-Mail:
RCreighton@lafreightliner.com

S P E C I F I C A T I O N P R O P O S A L

Description	Weight Front	Weight Rear
Price Level		
CONDOR PRL-42E (EFF:01/10/06)		
Data Version		
SPECPRO21 DATA RELEASE VER 001		

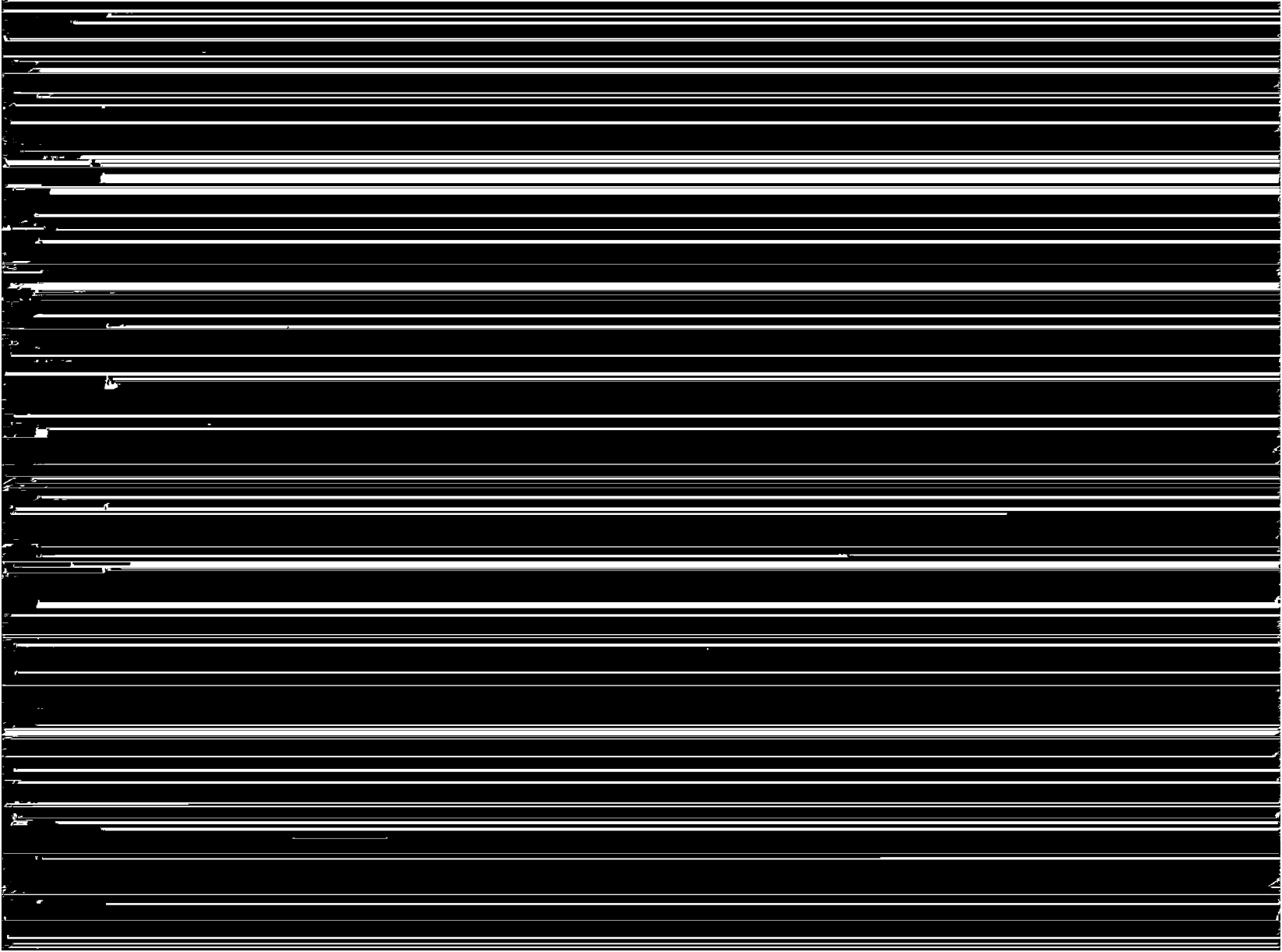

Prepared for:
 Barry Torgerson
 McNeilus Companies
 401 North Pepper
 PO Box 1588
 Colton, CA 92324
 Phone: 909-370-2100
 Cell: 909-374-2876
 E-Mail:
 btorgerson@mcneilusco.com

Prepared by:
 Ron Creighton
 LOS ANGELES FREIGHTLINER
 - WESTERN STAR
 2429 S. PECK ROAD
 WHITTIER, CA 90601
 Phone: 562-447-1200
 Cell: 562-755-6108
 E-Mail:
 RCreighton@lafreightliner.com

Description	Weight Front	Weight Rear
Engine		
* CUM C 8.3G+ 280 HP @ 2400 RPM ELEC N-GAS850 LB/FT @ 1400 RPM		
Engine Equipment		
* 2004 EPA/CARB EMISSION CERTIFICATION ENGINE MOUNTED OIL CHECK AND FILL		
* ONE PIECE VALVE COVER VERTICAL SNORKEL AND DONALDSON HIGH CAPACITY AIR CLEANER MOUNTED HORIZONTALLY BACK OF CAB STATIONARY VERTICAL AIR INTAKE SNORKEL, LOCATED RH SIDE OUTBOARD DONALDSON ONE-STAGE AIR CLEANER WITH SY-KLONE SERIES 9000 PRECLEANER AIR INTAKE PIPING - CLEANER TO ENGINE PLAIN BONNET AIR INTAKE HOOD/CAP	15	
* LN 12V 200 AMP 4863 ALTERNATOR WITH AC TAPS (3) ALLIANCE 1231 GROUP 31 12V MF 3300 CCA THREADED STUD BATTERIES	30	30
* ALUM BATT BOX FRAME MTD RH, SHORT SIDE TO RAIL		
* CUSTOM BATTERY BOX MOUNTING/LOCATION MOUNT BATTERY BOX 10" BELOW TOP OF CHASSIS FRAME AS FAR FORWARD ON RH RAIL FRAME GROUND RETURN FOR BATTERY CABLES; GROUND CABLE FROM LH AND RH FRAME TO ENGINE NON-METALLIC BATTERY BOX COVER FLAMING RIVER BATTERY SHUTOFF SW W/LOCK PROVISION MTD AFT SIDE OF BOX O/B OF FRM POLY-V BELTS WITH AUTOMATIC TENSIONER FOR FAN DRIVE		
* CUMMINS ENCORE ENGINE ELECTRONICS NO CLUTCH NO CLUTCH RELEASE BEARING LUBE		
* CUMMINS 18.7 CFM COMPRESSOR WITH INTERNAL SAFETY VALVE STANDARD AIR COMPRESSOR GOVERNOR TEFLON COMPRESSOR DISCHARGE LINE		
* ELECTRONIC ENGINE INTEGRAL SHUTDOWN PROTECTION SYSTEM SINGLE VERTICAL EXHAUST WITH PAINTED STACK LEFT SIDE	10	



Prepared for:
Barry Torgerson
McNeilus Companies
401 North Pepper
PO Box 1588
Colton, CA 92324
Phone: 909-370-2100
Cell: 909-374-2876
E-Mail:
btorgerson@mcneilusco.com

Prepared by:
Ron Creighton
LOS ANGELES FREIGHTLINER
- WESTERN STAR
2429 S. PECK ROAD
WHITTIER, CA 90601
Phone: 562-447-1200
Cell: 562-755-6108
E-Mail:
RCreighton@lafreightliner.com

Description	Weight Front	Weight Rear
FLEXIBLE STAINLESS STEEL EXHAUST PIPING		
STANDARD EXHAUST SYSTEM LENGTH		
SINGLE STAINLESS STEEL VERTICAL MUFFLER		
SINGLE STATIONARY OUTBOARD OF RAIL MOUNTED MUFFLER		
* STAINLESS STEEL MUFFLER INLET ELBOW(S) WITH CHROME STACK(S)		

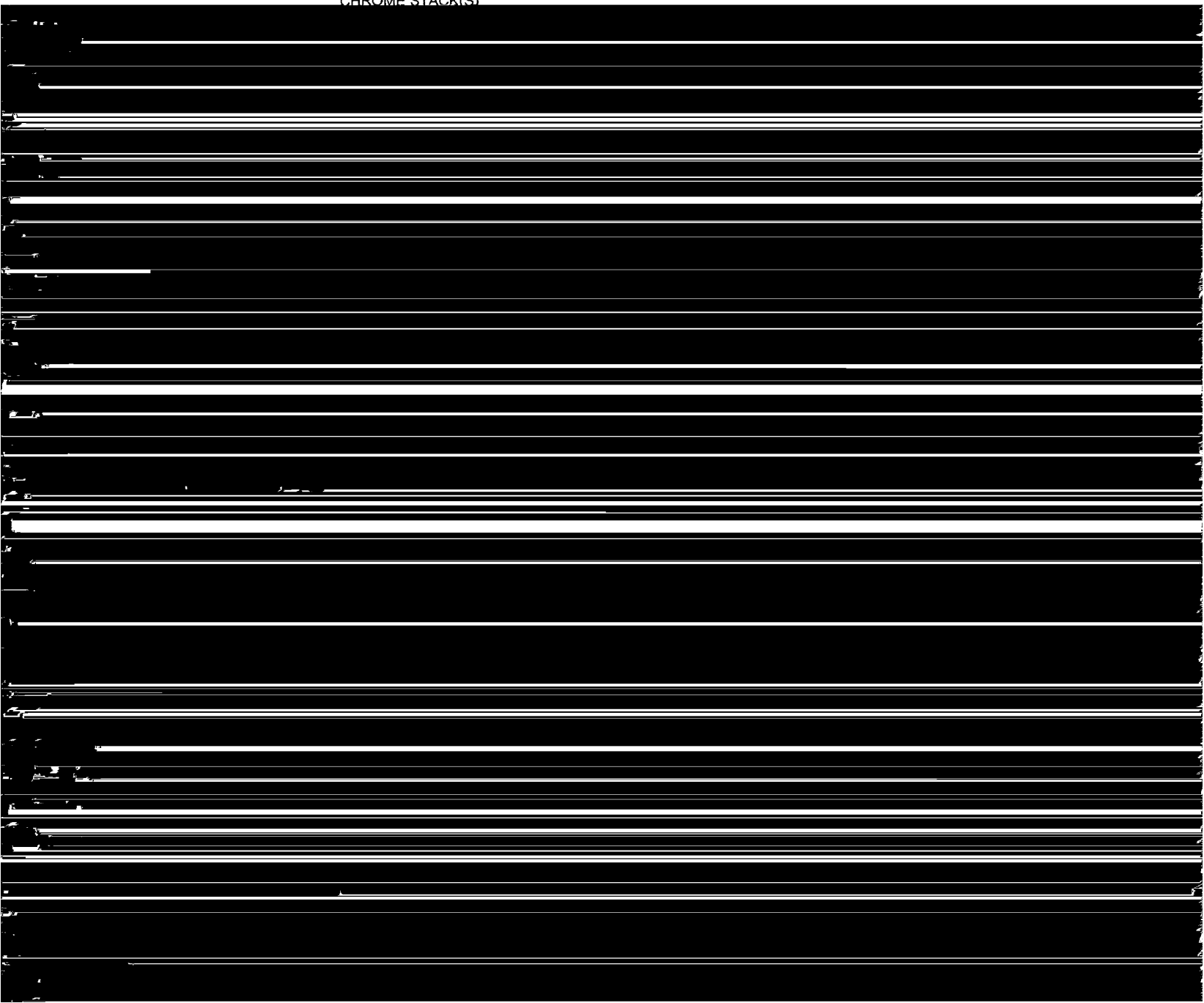

Prepared for:
Barry Torgerson
McNeilus Companies
401 North Pepper
PO Box 1588
Colton, CA 92324
Phone: 909-370-2100
Cell: 909-374-2876
E-Mail:
btorgerson@mcneilusco.com

Prepared by:
Ron Creighton
LOS ANGELES FREIGHTLINER
- WESTERN STAR
2429 S. PECK ROAD
WHITTIER, CA 90601
Phone: 562-447-1200
Cell: 562-755-6108
E-Mail:
RCreighton@lafreightliner.com

Description	Weight Front	Weight Rear
VEHICLE INTERFACE WIRING FOR REFUSE BODY BUILDER CONNECTOR, BACK OF CAB		
MAGNETIC PLUGS, ENGINE DRAIN, TRANSMISSION DRAIN, AXLE(S) FILL AND DRAIN		
* DASH MOUNTED ELECTRONIC CONTROL T- HANDLE SHIFT LEVER		
WATER TO OIL TRANSMISSION COOLER		
TRANSMISSION REAR SUPPORT LEAF SPRING		
TRANSMISSION OIL CHECK AND FILL WITH ELECTRONIC OIL LEVEL CHECK		

Front Axle and Equipment



Prepared for:
 Barry Torgerson
 McNeilus Companies
 401 North Pepper
 PO Box 1588
 Colton, CA 92324
 Phone: 909-370-2100
 Cell: 909-374-2876
 E-Mail:
 btorgerson@mcneilusco.com

Prepared by:
 Ron Creighton
 LOS ANGELES FREIGHTLINER
 - WESTERN STAR
 2429 S. PECK ROAD
 WHITTIER, CA 90601
 Phone: 562-447-1200
 Cell: 562-755-6108
 E-Mail:
 RCreighton@lafreightliner.com

Description	Weight Front	Weight Rear
17N MERITOR INTERAXLE DRIVELINE WITH FULL ROUND YOKES		
INTERAXLE AND/OR DIFFERENTIAL LOCKOUT WITH INDICATOR LIGHT		
CASTROL TRANSYND SYNTHETIC AUTOMATIC TRANSMISSION OIL AND MOBIL SYNTHETIC 75W-90W ALL AXLES		
MERITOR 16.5X8.62 Q+ CAST SPIDER CAM REAR BRAKES, DOUBLE ANCHOR, FABRICATED SHOES		120
REFUSE SEVERE SERVICE, NON-ASBESTOS REAR LINING		
STANDARD BRAKE CHAMBER LOCATION		
GUNITE CAST IRON REAR BRAKE DRUMS		
CHICAGO RAWHIDE SCOTSEAL REAR OIL SEALS		
MGM TR-T LONGSTROKE 2-DRIVE AXLES SPRING PARKING CHAMBERS		
HALDEX AUTOMATIC REAR SLACK ADJUSTERS		

Rear Suspension



Prepared for:
Barry Torgerson
McNeilus Companies
401 North Pepper
PO Box 1588
Colton, CA 92324
Phone: 909-370-2100
Cell: 909-374-2876
E-Mail:
btorgerson@mcneilusco.com

Prepared by:
Ron Creighton
LOS ANGELES FREIGHTLINER
- WESTERN STAR
2429 S. PECK ROAD
WHITTIER, CA 90601
Phone: 562-447-1200
Cell: 562-755-6108
E-Mail:
RCreighton@lafreightliner.com

Description	Weight Front	Weight Rear
BW DV-2 AUTO DRAIN VALVE WITH HEATER ON WET TANK, DV-2 WITHOUT HEATER ON ALL OTHER TANKS		
Trailer Connections		
AIR CONNECTIONS AND ANCHOR COUPLINGS TO FRONT OF FRAME FOR TOWING		10
PLUMBING FOR AUXILIARY AIR TANK WITH PROTECTED SUPPLY		
OMISSION OF STANDARD CABLE		

Wheelbase & Frame



Prepared for:
 Barry Torgerson
 McNeilus Companies
 401 North Pepper
 PO Box 1588
 Colton, CA 92324
 Phone: 909-370-2100
 Cell: 909-374-2876
 E-Mail:
 btorgerson@mcneilusco.com

Prepared by:
 Ron Creighton
 LOS ANGELES FREIGHTLINER
 - WESTERN STAR
 2429 S. PECK ROAD
 WHITTIER, CA 90601
 Phone: 562-447-1200
 Cell: 562-755-6108
 E-Mail:
 RCreighton@lafreightliner.com

	Description	Weight Front	Weight Rear
*	26" DIAMETER FUEL TANK(S)		
*	PLAIN ALUMINUM/PAINTED STEEL FUEL/HYDRAULIC TANK(S) WITH PAINTED BANDS FUEL TANK(S) FORWARD PLAIN STEP FINISH		
*	CNG/LNG PARKER HANNIFIN TYPE LH FILLER RECEPTACLE AND DUST CAP		
*	NO FUEL TANK DRAIN VALVES		
*	MVE LNG FUEL HEATER		
*	FUEL LINES WITH NATURAL GAS CHECK VALVE, REGULATOR AND SHUTOFF SOLENOID WITH MACROTECH VENT FILL PIPE CON. ROUTED TO UPRIGHT		
*	STAINLESS STEEL HIGH PRESSURE TUBING WITH FLEXIBLE STEEL WIRE REINFORCED NYLON LOW PRESSURE NATURAL GAS FUEL HOSE		
*	NO FUEL LINE INSULATION		

Prepared for:
Barry Torgerson
McNeilus Companies
401 North Pepper
PO Box 1588
Colton, CA 92324
Phone: 909-370-2100
Cell: 909-374-2876
E-Mail:
btorgerson@mcneilusco.com

Prepared by:
Ron Creighton
LOS ANGELES FREIGHTLINER
- WESTERN STAR
2429 S. PECK ROAD
WHITTIER, CA 90601
Phone: 562-447-1200
Cell: 562-755-6108
E-Mail:
RCreighton@lafreightliner.com

	Description	Weight Front	Weight Rear
*	ACCURIDE 29730A 22.5X9.00 10-HUB PILOT 10-HAND ALUMINUM DISC SPARE WHEEL		
*	SPARE WHEEL: ALCOA 893630 22.5X9.0 10-HUB PILOT ALUM, 3.12 INSET, 10-HAND		

Prepared for:
 Barry Torgerson
 McNeilus Companies
 401 North Pepper
 PO Box 1588
 Colton, CA 92324
 Phone: 909-370-2100
 Cell: 909-374-2876
 E-Mail:
 btorgerson@mcneilusco.com

Prepared by:
 Ron Creighton
 LOS ANGELES FREIGHTLINER
 - WESTERN STAR
 2429 S. PECK ROAD
 WHITTIER, CA 90601
 Phone: 562-447-1200
 Cell: 562-755-6108
 E-Mail:
 RCreighton@lafreightliner.com

Description	Weight Front	Weight Rear
RH DOWN VIEW MIRROR		
STANDARD SIDE/REAR REFLECTORS		
FIXED CAB MOUNTED STEPS RH/LH FOR CAB ENTRY		
20"X36" TINTED CENTER AND (2) 20"X15" TINTED OUTBOARD REAR WINDOWS	20	
TINTED DOOR GLASS		
RH AND LH ELECTRIC POWERED WINDOWS	4	
8"X34" TINTED VERTICAL UPPER SIDE WINDOWS LH AND RH	6	
TINTED WINDSHIELD		
ONE GALLON WINDSHIELD WASHER RESERVOIR LOCATED TO INBOARD SIDE OF UPRIGHT		
Cab Interior		
GRAY STANDARD INTERIOR		
ABS UPPER AND BALANCE PAINTED ALUMINUM LH DOOR TRIM		
ABS UPPER AND BALANCE PAINTED ALUMINUM RH DOOR TRIM		
SLIP RESISTANT FLOORING		
FORWARD ROOF MOUNTED CONSOLE		
LH/RH DOOR STORAGE POCKETS INTEGRATED INTO MOLDED DOOR PANELS		
(2) CUP HOLDERS LH AND RH INTEGRAL WITH ENGINE TUNNEL COVER		
(2) ROOF MOUNTED WINDSHIELD FANS	10	
2-1/2 LB. FIRE EXTINGUISHER	5	
FIRST AID KIT, MOUNTED BEHIND DRIVER ON CAB BACKWALL	2	
HEATER, DEFROSTER AND AIR CONDITIONER	60	
STANDARD HVAC DUCTING		
MAIN HVAC CONTROLS WITH RECIRCULATION SWITCH AND MANUAL AIR CONDITIONER ON/OFF SWITCH		
STANDARD HEATER PLUMBING		
SANDEN COMPACT AIR CONDITIONER COMPRESSOR		
RADIATOR MOUNTED AIR CONDITIONER CONDENSER		
BINARY CONTROL, R-134A, WITH RECEIVER DRIER		
CAB INSULATION WITH ADDITIONAL NOISE AND THERMAL TREATMENT		

Prepared for:
 Barry Torgerson
 McNeilus Companies
 401 North Pepper
 PO Box 1588
 Colton, CA 92324
 Phone: 909-370-2100
 Cell: 909-374-2876
 E-Mail:
 btorgerson@mcneilusco.com

Prepared by:
 Ron Creighton
 LOS ANGELES FREIGHTLINER
 - WESTERN STAR
 2429 S. PECK ROAD
 WHITTIER, CA 90601
 Phone: 562-447-1200
 Cell: 562-755-6108
 E-Mail:
 RCreighton@lafreightliner.com

Description	Weight Front	Weight Rear
AUTO SELF-RESET CIRCUIT BREAKERS AND FUSES		
12V NEGATIVE GROUND ELECTRICAL SYSTEM WITH SCHEMATIC MANUAL		
DOOR ACTIVATED CENTER DOME LIGHT WITH LIGHT MOUNTED SWITCH		
CAB DOOR LATCHES WITH MANUAL DOOR LOCKS		
(1) 12V POWER SUPPLY IN DASH		
TRIANGULAR REFLECTORS WITHOUT FLARES, MOUNTED BEHIND DRIVER ON CAB BACKWALL	10	
NATIONAL 2000 SERIES MID BACK DRIVER SEAT WITH ACTIVE AIR LUMBAR SUPPORT		
NATIONAL 2000 SERIES MID BACK NON SUSPENSION PASSENGER SEAT		
CORDURA PLUS CLOTH DRIVER SEAT COVER		
CORDURA PLUS CLOTH PASSENGER SEAT COVER		
3 POINT ADJUSTABLE D-RING RETRACTOR DRIVER AND PASSENGER SEAT BELTS		
ADJUSTABLE TILT AND TELESCOPING STEERING COLUMN		
2-SPOKE 18" (450MM) BLACK STEERING WHEEL(S)		
DRIVER/PASSENGER INTERIOR SUN VISORS		

Instruments & Controls

CONDOR STANDARD GAUGE PACKAGE		
BLACK GAUGE BEZELS		
INTEGRAL GAUGES MOUNTED IN INSTRUMENT PANEL CLUSTER		
GRAY CENTER INSTRUMENT PANEL		
LOW AIR PRESSURE LIGHT AND BUZZER		
2" PRIMARY AND SECONDARY AIR PRESSURE GAUGES		
AIR RESTRICTION GAUGE, AIR CLEANER MOUNTED		
ECCO MODEL 917 AUTOMATIC SELF-ADJUSTING BACKUP ALARM WITH REVERSE MOTION SENSOR		2
KEY OPERATED IGNITION SWITCH AND INTEGRAL START POSITION; 4 POSITION OFF/RUN/START/ACCESSORY		
INTEGRATED SPEEDOMETER MESSAGE CENTER LCD DISPLAY, DATA LINKED		
DIAGNOSTIC INTERFACE CONNECTOR, 6 PIN, SAE J1587/1708, LOCATED BELOW DASH		
ELECTRIC FUEL GAUGE WITH MECHANICAL PRESSURE GAUGE AT TANK FOR LNG		



Prepared for:
 Barry Torgerson
 McNeilus Companies
 401 North Pepper
 PO Box 1588
 Colton, CA 92324
 Phone: 909-370-2100
 Cell: 909-374-2876
 E-Mail:
 btorgerson@mcneilusco.com

Prepared by:
 Ron Creighton
 LOS ANGELES FREIGHTLINER
 - WESTERN STAR
 2429 S. PECK ROAD
 WHITTIER, CA 90601
 Phone: 562-447-1200
 Cell: 562-755-6108
 E-Mail:
 RCreighton@lafreightliner.com

Description	Weight Front	Weight Rear
ELECTRICAL ENGINE COOLANT TEMPERATURE GAUGE		
2" TRANSMISSION OIL TEMPERATURE GAUGE		
TRIP HOUR METER INTEGRAL WITH SPEEDOMETER MESSAGE CENTER (SMC)		
ELECTRIC ENGINE OIL PRESSURE GAUGE		
F/L XTA-2000 AM/FM/WB RADIO BY DELPHI	10	
ROOF/OVERHEAD CONSOLE MOUNTED RADIO		
(2) RADIO SPEAKERS (CAB ONLY)		
AM/FM FLEXIBLE COMPOSITE ANTENNA MOUNTED ON LH FRONT A-PILLAR		
NO CB RADIO/PROVISION		
NO CB ANTENNA, BRACKET OR LEAD		
* ELECTRONIC MPH SPEEDOMETER WITH SECONDARY KPH SCALE, WITHOUT ODOMETER		
ELECTRONIC TACHOMETER 3000 RPM		
IGNITION SWITCH CONTROLLED ENGINE STOP		
DASH CONTROL FOR REFUSE WORK BRAKE FOR FRONT AND REAR SERVICE BRAKES WITH TRANSMISSION AUTO NEUTRAL		
VOLTMETER; LOW VOLTAGE WARNING LIGHT AND BUZZER		
DUAL ELECTRIC MOTOR WINDSHIELD WIPER WITH DELAY		
MARKER LIGHT SWITCH INTEGRAL WITH HEADLIGHT SWITCH		
ONE VALVE PARKING BRAKE SYSTEM (PP1) OFFSET TOWARDS DRIVER POSITION		
SELF CANCELING TURN SIGNAL SWITCH WITH DIMMER, HEADLAMP FLASH, WASH/WIPE/INTERMITTENT		
NON-POLARITY SENSITIVE ELECTRONIC FLASHER		

Prepared for:
Barry Torgerson
McNeilus Companies
401 North Pepper
PO Box 1588
Colton, CA 92324
Phone: 909-370-2100
Cell: 909-374-2876
E-Mail:
btorgerson@mcneilusco.com

Prepared by:
Ron Creighton
LOS ANGELES FREIGHTLINER
- WESTERN STAR
2429 S. PECK ROAD
WHITTIER, CA 90601
Phone: 562-447-1200
Cell: 562-755-6108
E-Mail:
RCreighton@lafreightliner.com

Description	Weight Front	Weight Rear
Special Narrative Instructions		
* ULEV (ULTRA LOW-EMISSION VEHICLE) CERTIF		
TOTAL VEHICLE SUMMARY		

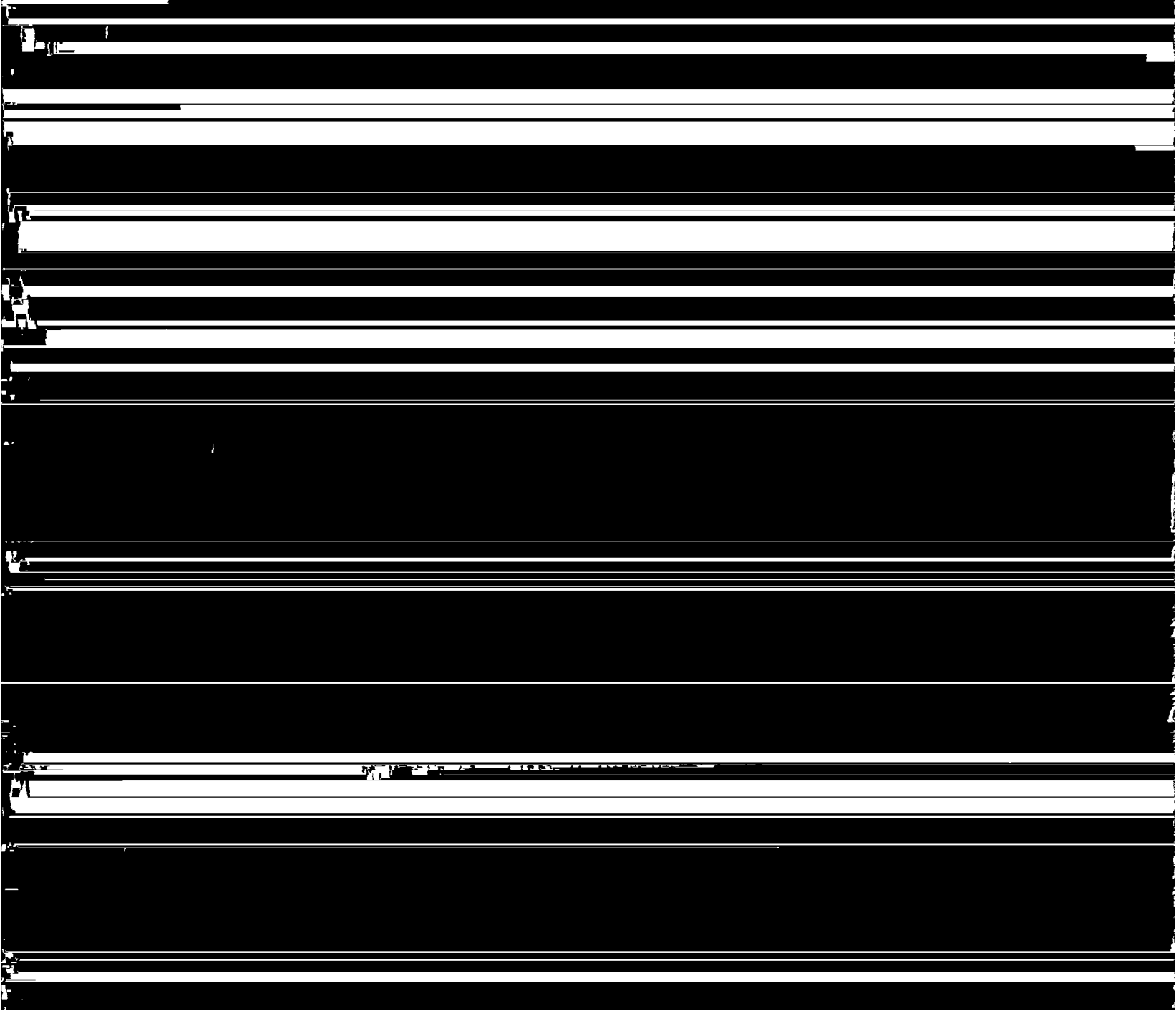

Prepared for:
 Barry Torgerson
 McNeilus Companies
 401 North Pepper
 PO Box 1588
 Colton, CA 92324
 Phone: 909-370-2100
 Cell: 909-374-2876
 E-Mail:
 btorgerson@mcneilusco.com

Prepared by:
 Ron Creighton
 LOS ANGELES FREIGHTLINER
 - WESTERN STAR
 2429 S. PECK ROAD
 WHITTIER, CA 90601
 Phone: 562-447-1200
 Cell: 562-755-6108
 E-Mail:
 RCreighton@lafreightliner.com

D I M E N S I O N S

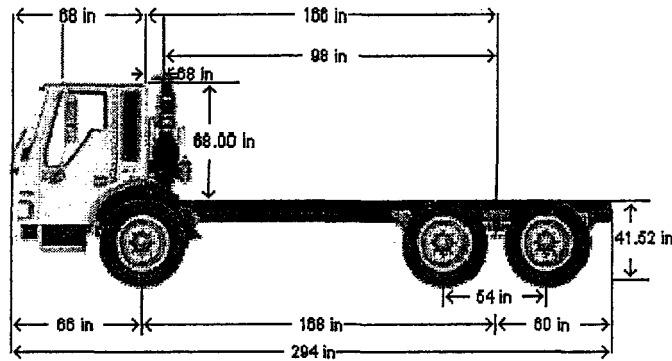

VEHICLE SPECIFICATIONS SUMMARY - DIMENSIONS

Model	FTLC
Wheelbase (545).....	4275MM (168") WHEELBASE
Rear Frame Overhang (552).....	1525MM (60") REAR FRAME OVERHANG
Cab Size (829).....	.68" BBC LOW CAB FORWARD ALUMINUM CAB



Prepared for:
 Barry Torgerson
 McNeilus Companies
 401 North Pepper
 PO Box 1588
 Colton, CA 92324
 Phone: 909-370-2100
 Cell: 909-374-2876
 E-Mail:
 btorgerson@mcneilusco.com

Prepared by:
 Ron Creighton
 LOS ANGELES FREIGHTLINER
 - WESTERN STAR
 2429 S. PECK ROAD
 WHITTIER, CA 90601
 Phone: 562-447-1200
 Cell: 562-755-6108
 E-Mail:
 RCreighton@lafreightliner.com

Exhaust System (016)..... SINGLE VERTICAL EXHAUST WITH PAINTED STACK LEFT SIDE

TABLE SUMMARY - DIMENSIONS

Dimension	Inches
Rim to Back of Cab (RBC)	67.0

Prepared for:
Barry Torgerson
McNeilus Companies
401 North Pepper
PO Box 1588
Colton, CA 92324
Phone: 909-370-2100
Cell: 909-374-2876
E-Mail:
btorgerson@mcneilusco.com

Prepared by:
Ron Creighton
LOS ANGELES FREIGHTLINER
- WESTERN STAR
2429 S. PECK ROAD
WHITTIER, CA 90601
Phone: 562-447-1200
Cell: 562-755-6108
E-Mail:
RCreighton@lafreightliner.com

GVWR

VEHICLE SPECIFICATIONS SUMMARY - GVWR

Model	FTLC
Cab Size (829)68" BBC LOW CAB FORWARD ALUMINUM CAB
Expected Front Axle(s) Load (lbs)	20000.0
Expected Pusher Axle(s) Load (lbs)	0.0
Expected Rear Axle(s) Load (lbs)	40000.0
Expected Tag Axle(s) Load (lbs)	0.0
Expected GVW (lbs)	60000
Expected GCW (lbs)	0.0
Front Axle (400)	FL-943 FL1 20,000# SINGLE FRONT AXLE
Front Suspension (620)	20,000# TAPERLEAF FRONT SUSPENSION
Front Hubs (418)	GUNITE IRON FRONT HUBS

Prepared for:
 Barry Torgerson
 McNeilus Companies
 401 North Pepper
 PO Box 1588
 Colton, CA 92324
 Phone: 909-370-2100
 Cell: 909-374-2876
 E-Mail:
 btorgerson@mcneilusco.com

Prepared by:
 Ron Creighton
 LOS ANGELES FREIGHTLINER
 - WESTERN STAR
 2429 S. PECK ROAD
 WHITTIER, CA 90601
 Phone: 562-447-1200
 Cell: 562-755-6108
 E-Mail:
 RCreighton@lafreightliner.com

	Front	Rear 1	Rear 2
Axle Component Weight Ratings			
Axles	20000	20000	20000
Suspension	20000	20000	20000
Hubs	20000	23000	23000
Brakes	21500	22500	22500
Wheels	20000	36000	36000
Tires	20000	33080	33080
Power Steering	22000	N/A	N/A
GAWR (per axle)	20000	20000	20000
GAWR (per axle system)	20000		40000
Expected Load (per axle system)	20000		40000
Vehicle GVWR Summary			
Calculated GVWR	60000		
Expected GVWR	60000		
All weights displayed in pounds			

Prepared for:
 Barry Torgerson
 McNeilus Companies
 401 North Pepper
 PO Box 1588
 Colton, CA 92324
 Phone: 909-370-2100
 Cell: 909-374-2876
 E-Mail:
 btorgerson@mcneilusco.com

Prepared by:
 Ron Creighton
 LOS ANGELES FREIGHTLINER
 - WESTERN STAR
 2429 S. PECK ROAD
 WHITTIER, CA 90601
 Phone: 562-447-1200
 Cell: 562-755-6108
 E-Mail:
 RCreighton@lafreightliner.com

F R A M E R B M

VEHICLE SPECIFICATIONS SUMMARY - FRAME RBM

Wheelbase (545) 4275MM (168") WHEELBASE
 Frame Rails (546) 7/16" X 3-11/16" X 11-1/8" STEEL FRAME (11.11MM X 282.6MM/.437" X 11.13")110KSI(546)
 Yield Strength (psi) 110000
 Section Modulus (per rail) (cu in) 22.25
 RBM (per rail) (lbf-in) 2448000

TABLE SUMMARY - FRAME RBM

Item	Description / Value
Wheelbase	4275MM (168") WHEELBASE
Frame	7/16" X 3-11/16" X 11-1/8" STEEL FRAME (11.11MM X 282.6MM/.437" X 11.13")110KSI
Inner Frame Reinforcement	None
Outer Frame Reinforcement	None
Yield Strength (psi)	110000
Section Modulus - per rail (cu in)	22.25
Frame RBM - per rail (lbf-in)	2448000



Weight Distribution

Customer: City of Long Beach XII

Requestor: B. Torgerson

Stirling Cooper

Prepared: J. Peterson

04/19/2006

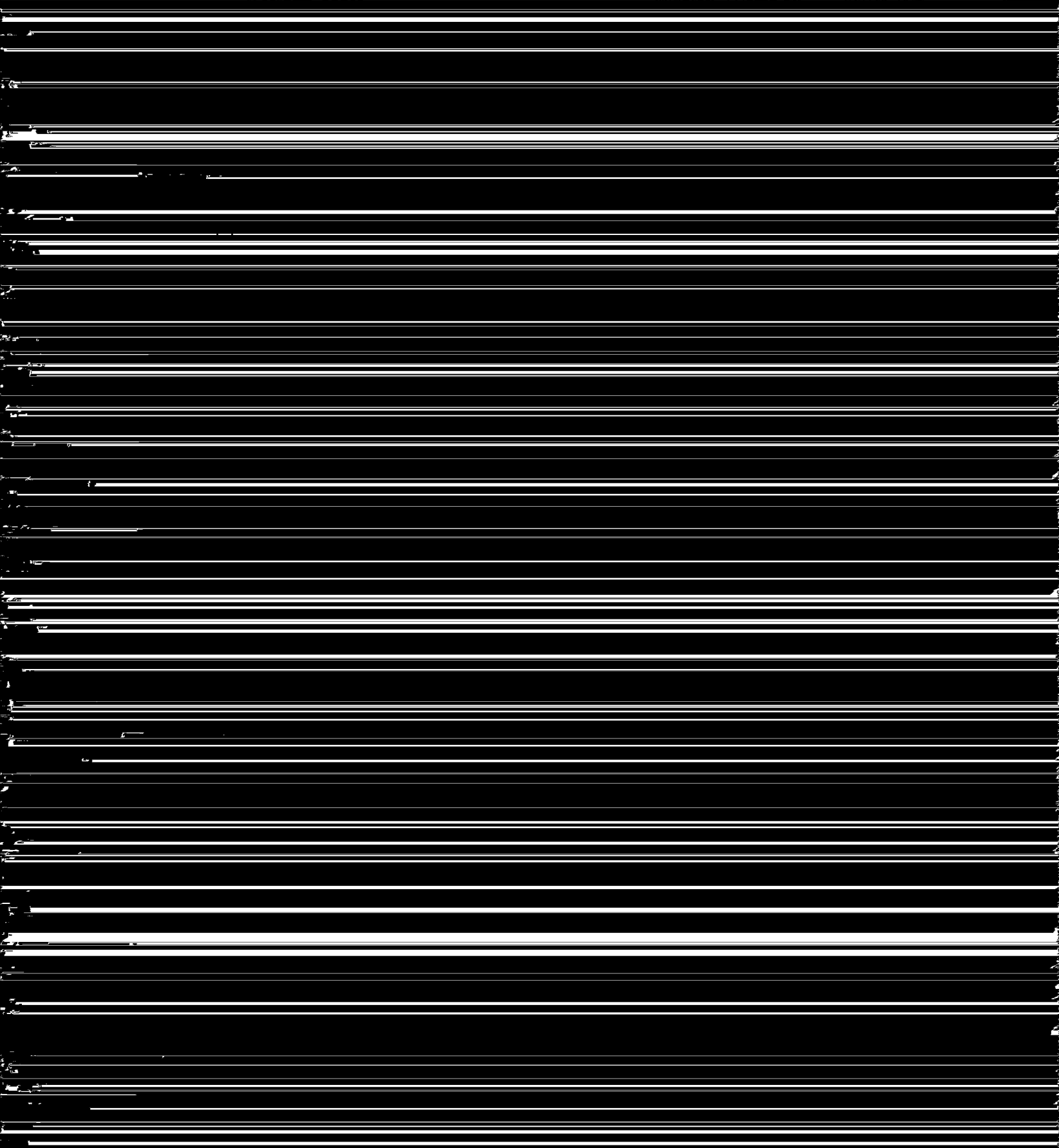

	Inches	Feet		CG	Weight		Weight	CG
Outer Bridge:	195	16	Chassis Total:	67.7	16,056	Body:	14,760.00	121.00
Rear Inner Bridge:	54	5	Chassis Front:	0.0	9,586	Payload:	14,695.00	107.00
Front Tandem Bridge:	0	0	Chassis Rear:	168.0	6,470			
Rear Tandem Bridge:	54	5	Chassis Options Total:	0.0	0			
			Body Total:	164.0	14,760			
			Body Options Total:	43.0	0			
			Tag:	0.0	0			
			Pusher:	0.0	0			
			Payload:	150.0	14,695			
					45,511			

<u>Center of Gravity Summary</u>				
Front of Body Location from Front Axle				43.0
Wheelbase				168.0
Actual Back of Cab to Rear Axle/Tandem				166.5
	<u>Chassis</u>	<u>Body</u>	<u>Payload</u>	<u>Body+Payload</u>
CG	67.7	121.0	107.0	114.0
Weight	16,056	14,760	14,695	29,455

<u>Auxillary Axle Effects</u>	Front	Pusher	Rear	Tag	Total
Chassis	9,586	N/A	6,470	N/A	16,056
Body	351	N/A	14,409	N/A	14,760
Pusher Up	0	UP	0	UP	0
Tag Up	0	UP	0	UP	0
Tare Weight	9,937	UP	20,879	UP	30,816
Payload	1,574	N/A	13,121	N/A	14,695
Total Aux Axles Up	11,512	UP	33,999	UP	45,511
Pusher Down	0	0	0	N/A	0
Tag Down	0	N/A	0	0	0
Net Pusher Down	0	0	0	N/A	0
Net Tag Down	0	N/A	0	0	0
Total Aux Axles Down	11,512	0	33,999	0	45,511

Base Chassis Weight: 16,056

Chassis Options

	<u>Weight</u>	<u>CG</u>
Totals:	0.00	0.00

Total Chassis Weight with Options: 16,056

Body Options

Total Body Weight with Options: 14,760

Note: Body and chassis weights are informational and subject to change. Payload configurations are approximate due to variations in payload content and consistency. Under no circumstance does McNeilus guarantee payload due to these variables.

Maximum Axle Loading

Warning: Body and chassis weights are informational and subject to change. Payload configurations are approximate due to variations in payload content and consistency. Under no circumstance does McNeilus guarantee payload due to these variables.

	Bridge Law Compliant	Alternative Loading
Payload Weight:	14,695.00	20,000.00
(lbs/yard)	735	1000
Pusher Force:	0.00	0.00
Tag Force:	0.00	0.00

<u>Axle Weights</u>	Front Axle Tandem	Pusher	Rear Axle Tandem	Tag	Rear Group	Gross
Axle Rating	20,000		40,000			
Bridge Law Compliant	11,512	0	33,999	0	33,999	45,511
Alternative Loading	12,080	0	38,736	0	38,736	50,816

Customer accepts this weight distribution and payload for this vehicle.

Signature: _____

Mr. John Seevers
City of Long Beach
2600 Temple Avenue
Long Beach, CA. 90806
Re: Pricing Differential & Deviations
from LBUSD Bid.

	Rear Loader	
Engine & Equipment	\$37,228.00	
Transmission & Equipment	\$217.00	
Rear Axle & Equipment	\$3,600.00	
Brake & Equipment	\$819.00	
Frame	\$1,045.00	
Fuel Tanks & Equipment	\$26,508.00	
Tires & Wheels	\$8,971.00	
Exterior Cab & Equipment	\$0.00	
Interior Cab & Equipment	\$1,440.00	
List Option Total	\$79,828.00	
Net Option Total	\$59,871.00	
Option Price Concession	<u>\$41,164.00</u>	
	\$18,707.00	\$0.00

Best Regards,
Ron Creighton
Los Angeles Freightliner
2429 S. Peck Road
Whittier, CA. 90601
(562) 447-1515 office
(562) 695-2697 fax
(562) 755-6108 cellular