

ORDINANCE NO.

AN ORDINANCE OF THE CITY COUNCIL OF THE CITY OF LONG BEACH AMENDING THE LONG BEACH MUNICIPAL CODE BY AMENDING SECTIONS 21.15.2510, 21.15.2520, 21.15.2550, 21.15.2570, 21.15.2571, 21.15.2573, 21.15.2577, 21.15.2580, 21.15.2600, 21.15.2620, 21.15.2630, 21.15.2700, 21.15.2710, 21.15.2720, 21.15.2730, 21.15.2740, 21.15.2750, 21.15.2980, BY AMENDING AND RESTATING IN ITS ENTIRETY CHAPTER 21.44, AND BY AMENDING SECTION 21.52.229; BY ADDING SECTIONS 21.15.2570.5, 21.15.2575, 21.15.2595, 21.15.2665, 21.15.2721, 21.15.2723, 21.15.2743, 21.15.2745, AND 21.15.2755; AND BY REPEALING SECTIONS 21.15.2540, 21.15.2560, 21.15.2640, 21.15.2670, 21.15.2680, 21.15.2690, AND 21.15.2725, ALL RELATING TO SIGNS

Section 1. Section 21.15.2510 of the Long Beach Municipal Code is amended to read as follows:

21.15.2510 Sign.

"Sign" means any device or structure used for visual communication or attraction, including any announcement, declaration, demonstration, display, illustration, insignia, model, statue, or symbol used to identify a place, or to advertise or promote the interest of any person; together with all appurtenant components, backgrounds, and supporting structures, except the building upon which a sign is placed. Official traffic-control devices are specifically exempted from this definition. The official flags of nations, states, counties, cities and recognized nonprofit

OFFICE OF THE CITY ATTORNEY
 CHARLES PARKIN, City Attorney
 333 West Ocean Boulevard, 11th Floor
 Long Beach, CA 90802-4664

1
2
3
4
5
6
7
8
9
10
11
12
13
14
15
16
17
18
19
20
21
22
23
24
25
26
27
28

1 organizations shall not be considered signs, but flags, banners or similar
2 devices containing a commercial message shall be signs.

3

4 Section 2. Section 21.15.2520 of the Long Beach Municipal Code is
5 amended to read as follows:

6 21.15.2520 Sign, abandoned.

7 "Abandoned sign" means the sign face, frame and supporting pole
8 or structure, and all appurtenances, of any sign for a business, institution,
9 or other land use which has abandoned the premises for ninety (90) days
10 or more, or any land use for which the business license has expired and
11 remained expired for one year. Abandoned sign also includes any
12 promotional activity sign for which the permit has expired. Signs
13 associated with a demolished or abandoned building shall also be
14 considered abandoned signs. See also "Abandoned" (Section 21.15.030).

15

16 Section 3. Section 21.15.2550 of the Long Beach Municipal Code is
17 amended to read as follows:

18 21.15.2550 Sign, awning.

19 "Awning sign" means a sign that is applied, painted or affixed to an
20 awning.

21

22 Section 4. Section 21.15.2570 of the Long Beach Municipal Code is
23 amended to read as follows:

24 21.15.2570 Sign, banner.

25 See "Sign, promotional activity – commercial" (Section 21.15.2720).

26 //

27 //

28 //

1 Section 5. Section 21.15.2571 of the Long Beach Municipal Code is
2 amended to read as follows:

3 21.15.2571 Sign, changeable copy.

4 A sign whose copy is periodically changed to advertise events,
5 sales, and the like, with detachable but motionless lettering that must be
6 manually installed, usually on a series of parallel tracks. A changeable
7 copy sign shall not include a "trivision" sign, electronic sign, electronic
8 message center sign, or time, date, and temperature sign.

9
10 Section 6. Section 21.15.2573 of the Long Beach Municipal Code is
11 amended to read as follows:

12 21.15.2573 Sign, residential neighborhood or commercial district identification.

13 A "residential neighborhood identification sign" or "commercial
14 district identification sign" identifies a residential neighborhood and/or
15 commercial or industrial district(s), and may announce its geographical
16 boundaries (i.e., now entering or leaving neighborhood or district name)
17 within the City. This sign shall always identify that the respective
18 neighborhood or district is part of the City.

19
20 Section 7. Section 21.15.2577 of the Long Beach Municipal Code is
21 amended to read as follows:

22 21.15.2577 Sign, electronic message center.

23 "Electronic message center sign" is a sign whose alphabetic,
24 pictographic, or symbolic informational content can be changed or altered
25 on a fixed display surface composed of electrically-illuminated or
26 mechanically driven changeable segments. This includes signs whose
27 informational content can be changed or altered by means of computer- or
28 circuit-driven electronic impulses. An electronic message center sign

1 displays only on-site sign copy, information, and advertising; otherwise it
2 shall be considered a billboard. Electronic message center sign does not
3 include a sign that displays only time, date, and/or temperature if it is six
4 (6) square feet or smaller.

5
6 Section 8. Section 21.15.2580 of the Long Beach Municipal Code is
7 amended to read as follows:

8 21.15.2580 Sign, freestanding.

9 "Freestanding sign" means a sign which is supported by a structure
10 connected permanently to the ground, or displayed directly upon a base
11 connected permanently to the ground, and which is not structurally
12 connected to a building or other structure. This includes but is not limited
13 to those signs known as "pole signs." See also "Monument sign" (Section
14 21.15.2620).

15
16 Section 9. Section 21.15.2600 of the Long Beach Municipal Code is
17 amended to read as follows:

18 21.15.2600 Sign, marquee/canopy.

19 "Marquee/canopy sign" means a sign that is attached to the vertical
20 face or the soffit of a marquee or canopy. See "Awning sign" (Section
21 21.15.2550).

22
23 Section 10. Section 21.15.2620 of the Long Beach Municipal Code is
24 amended to read as follows:

25 21.15.2620 Sign, monument.

26 "Monument sign" means a sign that is displayed directly on the
27 ground, on a base connected permanently to the ground, and which is not
28 structurally connected to a building or structure. See also "Freestanding

1 sign" (Section 21.15.2580).

2

3 Section 11. Section 21.15.2630 of the Long Beach Municipal Code is
4 amended to read as follows:

5 21.15.2630 Sign, neighborhood marker.

6 "Neighborhood marker sign" means a sign placed upon a street
7 light standard or traffic signal pole to identify a residential neighborhood or
8 commercial district. These signs are administered by the Department of
9 Public Works, and not regulated in Title 21 (see Section 21.44.240).

10

11 Section 12. Section 21.15.2700 of the Long Beach Municipal Code is
12 amended to read as follows:

13 21.15.2700 Sign, portable.

14 "Portable sign" means a sign standing upon the ground but not
15 permanently located upon a foundation. This includes, but is not limited to,
16 those signs known as "sandwich-board signs," "A-frame signs," and
17 "sidewalk signs."

18

19 Section 13. Section 21.15.2710 of the Long Beach Municipal
20 Code is amended to read as follows:

21 21.15.2710 Sign, projecting.

22 "Projecting sign" means a sign which is attached to, and projects
23 outward at an angle from, a wall or other essentially vertical plane of a
24 building or structure. A projecting sign also may be known as a "blade
25 sign."

26 //

27 //

28

1 Section 14. Section 21.15.2720 of the Long Beach Municipal
2 Code is amended to read as follows:

3 21.15.2720 Sign, promotional activity - commercial.

4 "Promotional activity sign-commercial" means any sign utilized to
5 promote or advertise a commercial activity or event that is permitted on a
6 temporary basis under the provisions of Section 21.44.410, for the
7 purpose of announcing an event, product, service, or sale of a temporary
8 nature. Promotional activity signs are made of non-permanent materials
9 such as cloth, vinyl, or mesh, and are not permanently attached or affixed
10 to a building. Promotional activity signs commonly are known as
11 "banners."

12
13 Section 15. Section 21.15.2730 of the Long Beach Municipal
14 Code is amended to read as follows:

15 21.15.2730 Sign, roof.

16 "Roof sign" means a sign that is mounted or positioned on the roof
17 of a building and which projects above the parapet wall of a building with a
18 flat roof, or above the eave line of a building with a sloped roof (gambrel,
19 gable or hip roof), or above the deck line of a building with a mansard roof.

20
21 Section 16. Section 21.15.2740 of the Long Beach Municipal Code is
22 amended to read as follows:

23 21.15.2740 Sign, temporary.

24 "Temporary sign" refers to those signs that are permitted on a
25 temporary basis in Division IV of Chapter 21.44. See also "Promotional
26 activity sign-commercial" (Section 21.15.2720).

27 //

28 //

1 Section 17. Section 21.15.2750 of the Long Beach Municipal
2 Code is amended to read as follows:

3 21.15.2750 Sign, wall.

4 "Wall sign" means a sign fastened to the wall of a building or
5 structure in such a manner that the wall becomes the supporting structure
6 for or forms the background surface of the sign. Such a sign may not
7 project more than fourteen inches (14") beyond the vertical wall surface or
8 it shall be considered a projecting sign.

9
10 Section 18. Section 21.15.2980 of the Long Beach Municipal
11 Code is amended to read as follows:

12 21.15.2980 Supergraphics.

13 "Supergraphic" means a sign, containing either on-site or off-site
14 advertising, consisting of sign copy and/or an image that is applied to a
15 building, structure, or wall, or projected onto a building, structure, or wall,
16 or printed on vinyl, mesh, fabric, or any other material, and hung from or
17 wrapped about a building or structure, and which does not comply with the
18 requirements for a permitted sign type under the provisions of Chapter
19 21.44, or the requirements for a billboard under Chapter 21.54. The term
20 "supergraphic" also shall include signs known as "building wraps."

21
22 Section 19. Chapter 21.44 of the Long Beach Municipal Code is
23 amended and restated in its entirety to read as shown on Attachment "A."

24
25 Section 20. Section 21.52.229 of the Long Beach Municipal Code
26 is amended to read as follows:

27 21.52.229 Electronic message center signs.

28 In addition to the required findings for a conditional use permit

1 (Section 21.25.206), the Planning Commission shall not approve a
2 conditional use permit for an Electronic Message Center sign unless
3 positive findings can be made for the following:

4 A. The proposed design of the electronic message center sign
5 is complete and consistent within itself and is compatible in design with
6 the architectural theme or character of the existing or proposed
7 development it will serve and the community in which it will be located.

8 B. The establishment of the proposed electronic message
9 center sign will not adversely affect the character, livability, or quality of life
10 of any residential community it will be adjacent to or located in.

11 C. The electronic message center sign shall not constitute a
12 hazard to the safe and efficient operation of vehicles upon a street or
13 freeway.

14 D. The applicant has demonstrated that the proposed electronic
15 message display surface is factory-certified as capable of complying with
16 the brightness standards in Section 21.44.850.

17
18 Section 21. Section 21.15.2570.5 is added to the Long Beach
19 Municipal Code to read as follows:

20 21.15.2570.5 Sign, building identification.

21 "Building identification sign" means a sign which serves to identify
22 only the name, address, and use or principal tenant of the premises upon
23 which it is located and provides no other advertisements or product
24 identification.

25
26 Section 22. Section 21.15.2575 is added to the Long Beach Municipal
27 Code to read as follows:

28 21.15.2575 Sign, cabinet.

1 “Cabinet sign” means sign with one or several faces, which
2 contains all the text and/or logo symbols of each face upon a facing made
3 of translucent and/or opaque material contained within a single enclosed
4 cabinet, box or can. A cabinet sign may or may not be internally
5 illuminated.

6
7 Section 23. Section 21.15.2595 is added to the Long Beach Municipal
8 Code to read as follows:

9 21.15.2595 Sign, interior.

10 “Interior sign” means a sign that is located between one (1) and six
11 (6) feet to the interior of any window through which the sign is visible.

12
13 Section 24. Section 21.15.2665 is added to the Long Beach Municipal
14 Code to read as follows:

15 21.15.2665 Sign, on-site directional.

16 “On-site directional sign” means a class of sign that directs persons
17 to a destination within the subject site, typically a parking lot. An on-site
18 directional sign contains simple information such as “Enter,” “Exit,” “This
19 Way,” or “Do Not Enter,” as well as a business name and/or logo. An on-
20 site directional sign is intended for traffic internal to the site, and is not
21 directed at traffic on an adjacent road or right-of-way.

22
23 Section 25. Section 21.15.2721 is added to the Long Beach Municipal
24 Code to read as follows:

25 21.15.2721 Sign, promotional activity – non-commercial.

26 “Promotional activity sign – non-commercial” means any sign made
27 of cloth or paper taking the form of a banner, placard, sign board, or
28 similar device or structure and which is utilized to promote, advertise, or

1 advocate for or against a particular person, event or activity in a non-
2 commercial context. Non-commercial promotional activity signs shall be
3 removed from a premise no later than five (5) days following the
4 conclusion of the activity or event promoted by such sign.

5
6 Section 26. Section 21.15.2723 is added to the Long Beach Municipal
7 Code to read as follows:

8 21.15.2723 Sign, push-through.

9 "Push-through sign" or "push-through cabinet sign" refers to a
10 cabinet sign with sign copy rendered in relief either in front of or behind
11 the sign face, similar to channel letters. A push-through sign typically is
12 internally illuminated with an opaque face, creating a halo effect, although
13 other designs such as illuminated letters or exposed neon in open-faced
14 letters are acceptable as well.

15
16 Section 27. Section 21.15.2743 is added to the Long Beach Municipal
17 Code to read as follows:

18 21.15.2743 Sign, through-the-face.

19 See "Sign, push-through" (Section 21.15.2723).

20
21 Section 28. Section 21.15.2745 is added to the Long Beach Municipal
22 Code to read as follows:

23 21.15.2745 Sign, traffic directional.

24 "Traffic directional sign" means any sign displayed to ensure the safe
25 and orderly flow of automobile traffic on private property. These consist of
26 stop signs, one-way signs, do not enter signs, speed limit signs, left/right
27 turn-only signs, no left/right turn signs, and other traffic signs of like
28 purpose. Traffic directional signs do not contain business information or

1
2
3
4
5
6
7
8
9
10
11
12
13
14
15
16
17
18
19
20
21
22
23
24
25
26
27
28

directions to a destination. Traffic directional signs shall conform to official traffic control device standards as directed by the City Traffic Engineer.

Section 29. Section 21.15.2755 is added to the Long Beach Municipal Code to read as follows:

21.15.2755 Sign, wall painted.

“Wall-painted sign” means a sign that is painted on a building wall in lieu of a permanent, fixed wall sign structure.

Section 30. Sections 21.15.2540, 21.15.2560, 21.15.2640, 21.15.2670, 21.15.2680, 21.15.2690, and 21.15.2725 of the Long Beach Municipal Code are hereby repealed.

Section 31. The City Clerk shall certify to the passage of this ordinance by the City Council and cause it to be posted in three conspicuous places in the City of Long Beach, and it shall take effect on the thirty-first day after it is approved by the Mayor.

//
//

OFFICE OF THE CITY ATTORNEY
CHARLIE PARKIN, City Attorney
333 West Ocean Boulevard, 11th Floor
Long Beach, CA 90802-4664

1
2
3
4
5
6
7
8
9
10
11
12
13
14
15
16
17
18
19
20
21
22
23
24
25
26
27
28

I hereby certify that the foregoing ordinance was adopted by the City Council of the City of Long Beach at its meeting of _____, 2013, by the following vote:

Ayes:	Councilmembers:	_____

Noes:	Councilmembers:	_____

Absent:	Councilmembers:	_____

City Clerk

Approved: _____

Mayor

Chapter 21.44 – On-Premises Signs

Contents

Introduction and General Provisions	
Division I	Major Signs
Division II	Special Major Signs
Division III	Minor Signs
Division IV	Temporary Signs
Division V	Permit Exempt Signs
Division VI	Prohibited Signs
Division VII	Nonconforming and Illegal Signs and Other Provisions
Division VIII	Electronic Message Center Signs
Division IX	Signs on Public Property

21.44.010 – Purpose.

This Chapter provides standards for on-premises signs to safeguard life, health, property, safety, and public welfare, including aesthetics and the visual environment, while encouraging creativity, variety, compatible design, and enhancement of the City's image. The City recognizes that the location, number, size and design of signs significantly influences the City's visual environment and the perception of the City's economic condition. The specific purposes of this Chapter are to:

- A. Provide each sign user an opportunity for effective identification by regulating the time, place, and manner under which signs may be displayed;
- B. Maintain a content-neutral approach to sign regulation so as not to inhibit protected forms of freedom of expression;
- C. Regulate the number and size of signs according to standards consistent with the purpose of the City's various zoning districts and the intent of the Zoning Regulations;
- D. Protect all zoning districts from the adverse impacts of excessive numbers or sizes of signs, and signs of poor quality design;
- E. Encourage creative, well-designed signs that contribute in a positive way to the City's visual environment, and help maintain an image of quality for the City;
- F. Ensure that signs are responsive to the aesthetics and character of their particular location (adjacent buildings and surrounding neighborhood), and that signs are compatible and integrated with their building's architectural character and design (including historic elements), and with other signs on the site; and
- G. Ensure the quality of the City's visual environment and appearance by avoiding sign clutter, signs of excessive size, and signs of poor quality design, and by subjecting certain signs to the necessary discretionary processes.

21.44.020 – Accessory uses. On-premises signs are permitted in all districts as accessory uses only, subject to the provisions outlined in this Chapter.

21.44.030 – Sign permit required.

- A. **Required.** A sign permit is required to display, enlarge, modify, relocate or change in any way, other than to perform general maintenance, repair or complete removal, an on-premises sign in any zoning district, unless such action is expressly exempted by this Chapter.
- B. **Jurisdiction.** The Department of Development Services shall be responsible for reviewing sign permit applications and issuing sign permits.
- C. **Filing Of Application.** Applications for sign permits shall be filed with the Director of Development Services on forms provided by the Department of Development Services. Filing fees, as established by resolution of the City Council, shall be filed with the application. Additional information shall be provided as required by the Director of Development Services.
- D. **Time Limit.** Permits shall be used within one hundred eighty (180) days of issuance, otherwise they shall be null and void.

21.44.035 – Discretionary processes. A waiver from the provisions of these sign regulations may be considered through the procedures set forth in this Section. However, any prohibited signs, including those listed in Section 21.44.600 and any sign not specifically permitted, shall not be approved except through the provisions of Division III (Standards Variance) of Chapter 21.25—Specific Procedures.

- A. **Sign standards waiver.** Repealed.
- B. **Creative sign permit.**
 1. This Section establishes standards and procedures for the review and approval of Creative Sign Permits. The purposes of the Creative Sign Permit are to:
 - a. Encourage signs of unique design that exhibit a high degree of imagination, inventiveness, spirit, and thoughtfulness; and
 - b. Provide a process for the application of sign regulations in ways that will allow creatively designed signs that make a positive visual contribution to the overall image of the City, while mitigating the impacts of large or unusually designed signs.
 2. **Applicability.** An applicant may apply for a Creative Sign Permit in order to request approval of development standards that differ from the provisions of this Chapter, but comply with the purpose and findings of this Section. However, the Creative Sign Permit process shall not be used to allow any prohibited sign type or feature.
 3. **Application.** A Creative Sign Permit application shall include all information and materials required by the Department, and the filing fee as specified in a fee resolution to be adopted by the City Council.
 4. **Approval authority.** An application for a Creative Sign Permit shall be subject to review and approval or disapproval by the Site Plan Review

Committee, under the procedures set forth in Chapter 21.25 (Specific Procedures), Division III—Site Plan Review.

5. **Findings.** The Site Plan Review Committee shall not approve a Creative Sign Permit unless the proposed sign meets the following design criteria (in addition to the findings required in Chapter 21.25—Specific Procedures):
 - a. **Design quality.** The sign shall:
 - i. Constitute a substantial aesthetic improvement to the site and shall have a positive visual impact on the surrounding area;
 - ii. Be of unique design, and exhibit a high degree of imagination, inventiveness, spirit, and thoughtfulness; and
 - iii. Provide strong graphic character through the imaginative use of color, graphics, proportion, quality materials, scale, and texture.
 - b. **Contextual criteria.** The sign shall contain at least one of the following elements:
 - i. Classic historic design style;
 - ii. Creative image reflecting current or historic character of the City; or
 - iii. Inventive representation of the logo, name, or use of the structure or business.
 - c. **Architectural criteria.** The sign shall:
 - i. Utilize or enhance the architectural elements of the building; and
 - ii. Be placed in a logical location in relation to the overall composition of the building's facade and not cover any key architectural features and details of the facade.
 - d. **Impacts on surrounding uses.** The sign shall be located and designed not to cause light and glare impacts on surrounding uses, especially residential uses.

C. Sign Program.

1. This Section establishes standards and procedures for the review and approval of Sign Programs. The purpose of a Sign Program is to:
 - a. Ensure that all signs on a subject property are of complementary style and design, and are compatible with the architecture and theme of the property,
 - b. Provide a process for the review of said signs to ensure that new developments or major remodels achieve the highest quality of design by complementing the development with high-quality signs, and
 - c. Establish special sign criteria and standards for a given property when such additional regulation or waivers from the provisions of this Chapter are considered appropriate and beneficial.

2. **Applicability.** Application for a Sign Program shall be required for the following:
 - a. Any sign application submittal for five (5) or more new or replacement signs (not including minor, exempt, or temporary signs) intended to be placed on a site,
 - b. Any new commercial, industrial or, institutional building(s),
 - c. Any new mixed-use development with 3 or more non-residential tenant spaces, and
 - d. Any residential project consisting of 5 or more new dwelling units.
 3. **Application.** A Sign Program application shall include all information and materials required by the Department, and the filing fee as specified in a fee resolution to be adopted by the City Council.
 4. **Approval authority.** An application for a Sign Program shall be subject to review and approval or disapproval by the Site Plan Review Committee, under the procedures set forth in Chapter 21.25 (Specific Procedures), Division III—Site Plan Review.
 5. **Findings.** The Site Plan Review Committee shall not approve a Sign Program unless the proposed Sign Program meets the following design criteria (in addition to the findings required in Chapter 21.25—Specific Procedures):
 - a. All signs in the Sign Program are designed in such a manner so as to be internally consistent, coordinated, and whole within themselves, and harmonious with any existing signs remaining on the site.
 - b. Any existing signs on the site, if they are to remain, are of high quality design and materials, and complement the existing or proposed building and architecture, and will be complemented by the new signs in the Sign Program as well.
 - c. All signs in the Sign Program will complement and enhance the architectural theme of the subject property.
 - d. All signs in the Sign Program comply with the standards of this Chapter, unless specific exemptions have been granted in the interest of enhanced design and compatibility, and such exemptions are not contrary to the intent of this Chapter.
 6. **Waiver of standards.** A waiver from the development standards of this Chapter may be granted for signs in a Sign Program if the findings required for a Creative Sign Permit are made by the Site Plan Review Committee, and the waiver will achieve the specified purpose of a Creative Sign Permit. However, prohibited signs shall not be approved through a Sign Program.
- D. Neon Outlining or Architectural lighting of Buildings.** Neon tubing lighting, stringed lighting, and other architectural lighting used to outline buildings or emphasize architectural elements of a building shall not be considered signs or sign illumination, but rather an architectural element

subject to review and approval through the site plan review process as specified in Division V of Chapter 21.25—Specific Procedures.

21.44.050 – General performance and development standards for all signs.

- A. **Signs Subject To Standards.** All signs shall be subject to the development standards specified in this Chapter. The only exceptions shall be for signs that receive waivers from specific standards subject to the Creative Sign Permit or Standards Variance processes; all other standards shall continue to apply.
- B. **Measurement of sign area.** Where sign area is required to be measured for the purposes of this Chapter, it shall be measured in accordance with the definition of “sign area” contained in Section 21.15.2530. See Figure 44-1.

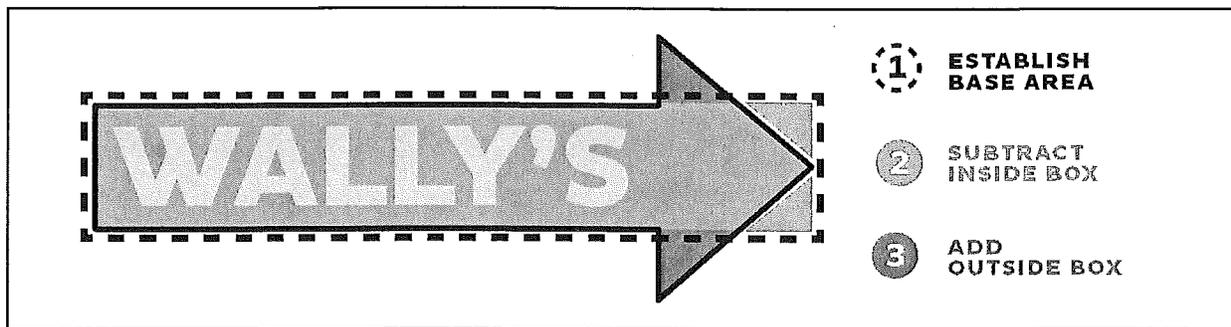

Figure 44-1. Measurement of sign area.

- C. **Maintenance.** All signs shall be kept in a well-maintained condition. No sign shall be displayed which, in the judgment of the Director of Development Services, or his or her designee, is not in good repair and maintained in a safe condition. All signs must be kept free from deterioration, free from defective parts, free from burned out lamps and peeling paint, and must be able to withstand the wind pressure for which it was originally designed.
- D. **Removal of signs.** The following shall apply to removal of signs:
1. **Time limit.** Except as otherwise specifically provided for in this Chapter, a sign shall be removed within thirty (30) days of disuse of the business, building, or other establishment for which it was emplaced.
 2. **Repair of building after removal.** Within thirty (30) days of the removal of a sign from a building, the wall of the building shall be repaired to remove any blemish left by the removal.
 3. **Complete removal.** When a sign is removed, all supporting structures, cabinets, frames and other appurtenances of the sign shall be removed as well.
- E. **Prohibited sign copy.** The primary purpose of an on-premises sign is identification, and not advertising; therefore no major sign, special major sign, or minor sign subject to this Chapter shall display prices for products or services. Changeable copy signs, promotional activity signs, electronic message center signs, and gas station price signs are exempt from this restriction.

- F. **Contact information.** In addition to other permitted sign copy, up to three (3) square feet of the allowable sign area may be used to display contact information for the on-premises establishment where the sign is located. This may take the form of telephone numbers, email or web addresses, and the like.
- G. **Clearance.** The vertical clearance between grade and the lowest point of a sign projecting over a pedestrian or vehicular path shall be eight (8) feet for pedestrian use and fifteen (15) feet for vehicular use. No sign shall project over an alley or at-grade parking space.
- H. **Light control.** No sign or sign lighting source shall cause or allow trespass of light onto any adjacent property, any residential dwelling unit, or into the public right-of-way.

21.44.060 – Design standards for all signs. The following standards shall apply to the design of all signs subject to this Chapter, for the purpose of carrying out the intent and achieving the goals of this Chapter set forth in Section 21.44.010 – Purpose.

- A. **Character.** Signs shall enhance the public realm and aid in the creation of a street's character. No sign shall impede pedestrian traffic, block sight lines in the public viewshed, or disturb adjacent residences.
- B. **Complementary.** The color, material, scale, lettering, and lighting shall complement the surrounding street environment and buildings that the sign addresses.
- C. **Size.** Signs shall never overpower the building. The sign shall fit comfortably into the architecture and character of the building or storefront. Signs shall be mounted in a manner that does not detract from the building's architectural presence and aesthetics.
- D. **Audience.** Signs intended for tourists, locals, or different age groups can suffer from poor sign design. Therefore, regardless of the intended audience, sign design shall conform to these design principles.
- E. **Concise.** Information on signs shall be brief, clear, and simple with appropriately-sized lettering, and a clear information hierarchy. When appropriate, symbols may be used in place of text.
- F. **Illumination.** Lighting used with signs shall be focused and minimal, especially for exterior-lit signs. Lighting shall be in scale with the sign and building. Design of sign illumination shall make every effort to avoid contributing to night-sky light pollution.
- G. **Consistency.** Signs shall be consistent across a building or property. If multiple tenants are listed on a single sign or a multi-tenant building, variation between size and typeface of tenant names and color shall be limited to a palette of three or fewer options.
- H. **Timelessness.** Sign design should convey a timeless character of a street, place, or business, and should avoid design tendencies associated with fleeting trends. Signs also shall be designed with durable, long-lasting materials, and shall be well-maintained.

21.44.062 – Additional design standards for non-residential signs. In addition to the design standards for all signs specified in Section 21.44.060, the following design standards shall apply to all non-residential signs:

- A. Signs should be consistent with the overall design and identity of the building, including the architecture and landscaping. Signs should complement the overall aesthetic of the building and site.
- B. If more than one sign type is necessary on a single façade, all signs shall be scaled in a clear hierarchy and shall address different viewer orientations and audiences.
- C. Buildings with multiple tenants or storefronts shall use the same sign strategy at every entrance, storefront, or tenant suite, in order to reduce sign confusion and present an organized visual environment.
- D. If multiple tenants are listed on a single sign, size and typeface of tenant names shall be kept consistent.
- E. For sites with several buildings, or buildings that are part of an industrial, business, or institutional campus, sign consistency shall be ensured through the following:
 1. Signs shall be visible from the public rights-of-way bounding the site, and shall communicate the necessary information clearly.
 2. Since campuses may house multiple tenants of differing types, the design identity of signs shall be capable of incorporating an array of styles and typefaces for the differing names and logos. However, the size of tenant names, logos, and color palettes shall be consistent with each other.
- F. Pedestrian-oriented signs are encouraged. Signs shall be scaled appropriately, including window signs, projecting (blade) signs, directory signs, and other pedestrian-oriented signs.
- G. Illumination should be used to accent signs, consistent with the building's character. Trespass of light and glare from sign illumination onto any adjacent dwelling units or other property, whether residential or nonresidential, is strictly prohibited.
- H. Signs and wayfinding features shall be incorporated with public art or placemaking objects where possible.
- I. Placement of signs in the public right-of-way should be uniform and designed at the correct scale for the intended reader, for both motorists and pedestrians.

21.44.064 – Additional design standards for residential signs. In addition to the design standards for all signs specified in Section 21.44.060, the following design standards shall apply to all residential signs:

- A. Signs should be integrated with the building's architecture and landscaping. Signs should be consistent with the design approach and convey a clear hierarchy of information.
- B. Signs shall identify primary entrances, the street address, and other necessary information, while maintaining an understated and minimal aesthetic.

- C. Mixed-use (commercial and residential) projects with commercial uses on the ground floor shall comply with the design standards for non-residential signs specified in Section 21.44.062.
- D. Illumination shall be designed to ensure adequate sign visibility and safety, but shall never create light trespass into residential units or onto adjacent properties.

Division I – Major Signs

21.44.100 – Development Standards—Major signs. Wall signs, projecting (blade) signs, freestanding or monument signs, awning signs, and building identification signs shall all be considered major signs. A freestanding sign and a projecting sign may not be located on the same property, but any other major sign combination is possible subject to the development standards outlined in this Chapter. See Figure 44-2, Major Signs.

21.44.102 – Copy. For all major sign types, sign copy shall be limited to the identification of the business, and up to two products or services sold or available on the premises. Copy shall not be placed on the edges of any sign.

21.44.105 – Standards by zoning districts. Each type of major sign shall be allowed in certain zoning districts as provided in Table 44-1.

**Table 44-1
Zoning Districts for Major Signs**

Zoning Districts	Sign Types					
	Wall sign	Projecting sign	Free-standing sign	Monument sign	Awning sign	Building Identification Sign
CNP, CNA, CNR	Y	Y	N	Y	Y	Y
CCA, CCP, CCR, CCN	Y	Y	Y	Y	Y	Y
CHW, IL, IM, IG, IP	Y	Y	Y	Y	Y	Y
R-1 and R-2 zones*	N	N	N	N	Y	N
R-3*, R-4*, and RM zones	N	N	N	N	Y	Y
I, P, PR	Y	Y	Y	Y	Y	Y
Residential and mixed-use character PDs**	Y	Y	N	Y	Y	Y
Commercial and industrial character PDs**	Y	Y	Y	Y	Y	Y
Abbreviations: Y = Yes (permitted), N = Not permitted, PD = Planned Development District						
* Commercial uses in these zoning districts, including legal nonconforming uses, shall be subject to the sign types restrictions specified for the CNP, CNA, and CNR districts.						
** In all PDs, sign regulations specified within each PD ordinance take precedence over the provisions of this Chapter. In cases of doubt, or where the several subareas of a given PD are of differing character, the Zoning Administrator shall determine which standards should apply.						

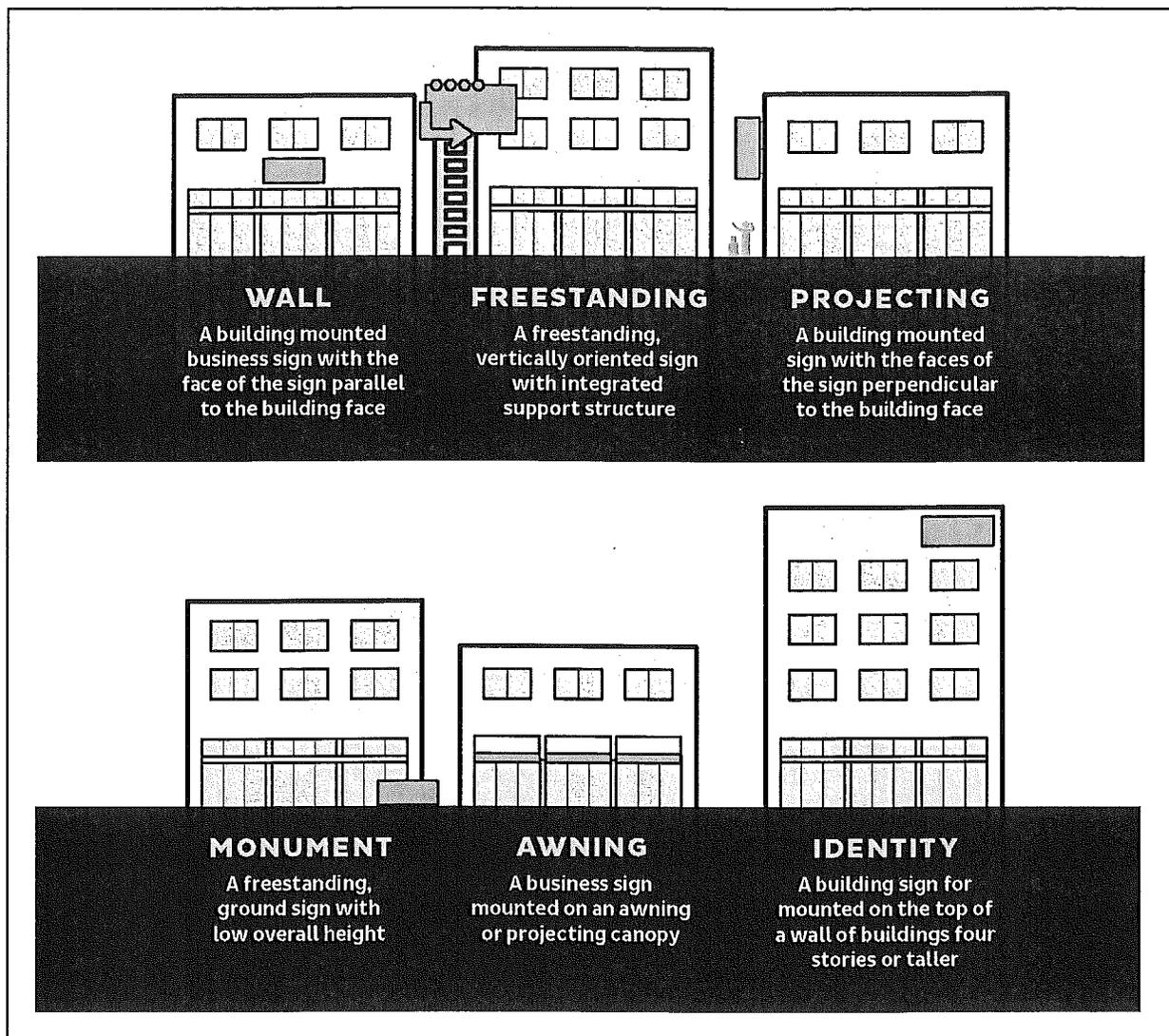

Figure 44-2. Major Signs.

21.44.120 – Wall signs. Wall signs are permitted for any business with frontage on a street, parking lot, public walkway within a mall, or which has exterior building frontage without facing a street, parking lot or mall.

A. **Number.** One per wall, or one per business for buildings with multiple tenants/businesses fronting on a street. In addition to the primary wall sign, secondary wall signs identifying up to two products or services are permitted provided that the cumulative wall sign area does not exceed the allowable limits established in Subsection 21.44.120.B.

B. **Area.**

1. **Wall Facing Street.** The total area of all wall signs facing a street shall not exceed one square foot of sign area per linear foot of building wall; provided, that not more than one hundred (100) square feet shall be allowed on any sign facing a residential, local or collector street and not

more than two hundred fifty (250) square feet shall be allowed for any sign facing a major or minor arterial. See Figure 44-3.

2. **Wall Facing Side Or Rear Yard.** The area of permitted wall signs facing side or rear yards shall not exceed one square foot of sign area for each linear foot of building wall.
3. **Curved or Angled Wall on a Corner.** A curved or angled wall located on a corner shall be considered to be a separate wall for purposes of this Section.
4. **Transference Of Sign Area.** Allowed sign area cannot be transferred from one building side or wall to another.
5. **Icons And Models.** Wall signs in the shape of icons, models, or logos shall be permitted provided that the cumulative wall sign area for all signs does not exceed the allowable limits. To calculate the area of two-dimensional (2-D) signs, the sign's length and width shall be multiplied. The area of three-dimensional (3-D) signs shall be measured as a longitudinal section of the icon or model.

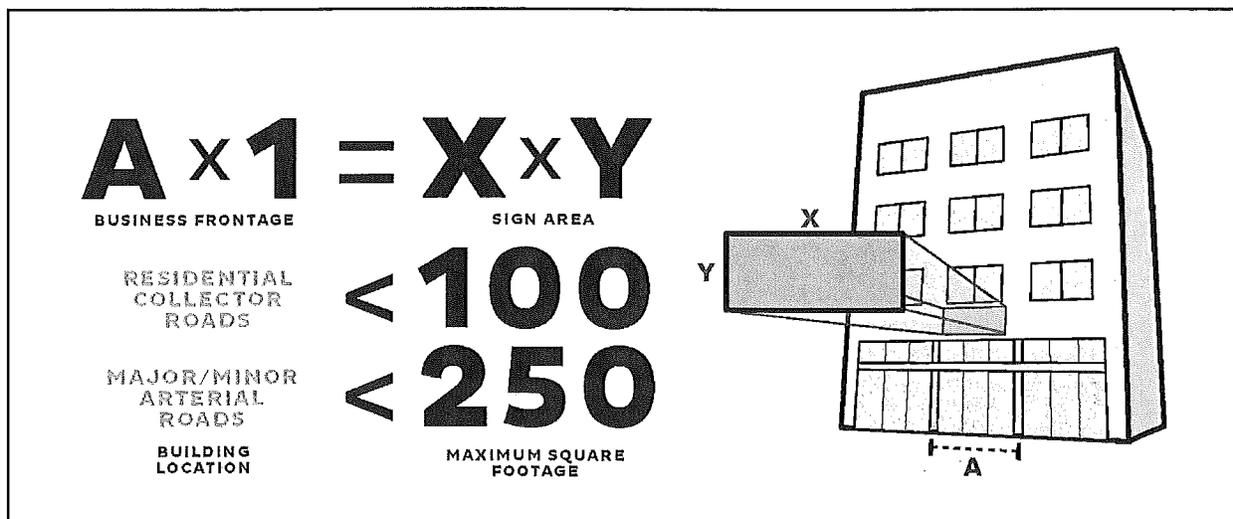

Figure 44-3. Area of a wall sign.

C. **Height.** The maximum height of wall signs above grade, to the highest point of the sign shall be as follows:

1. For a one-story building, the highest point of the sign shall not be located above the top of the parapet wall for a flat roof, or above the top of a mansard roof, or above the ridge of a sloped roof.
2. For a multi-story building with commercial tenants on the ground floor only, a wall sign shall not be located above the windowsill line of the second floor. This does not include building identification signs.
3. For a multi-story building with commercial tenants on the ground floor and floor(s) above, a wall sign shall be located on the same floor as

said tenant, and shall not be located above the windowsill line of the floor above said tenant. Wall signs shall not be allowed for commercial tenants on the third story and above. This does not include building identification signs.

4. For buildings with glass curtain wall systems, signs shall be allowed for ground-floor tenants only and not on any stories above the ground floor. This does not include building identification signs.

D. **Location.** No wall sign shall extend beyond the perimeter of the signable area (as defined in Section 21.15.2770) on which it is displayed, or above the top of the parapet wall of a flat-roofed building, or above the top of a mansard roof. A sign displayed above the eave line of a sloped roof building shall be considered a roof sign. No wall sign shall be located upon an architectural protrusion. See Figure 44-4.

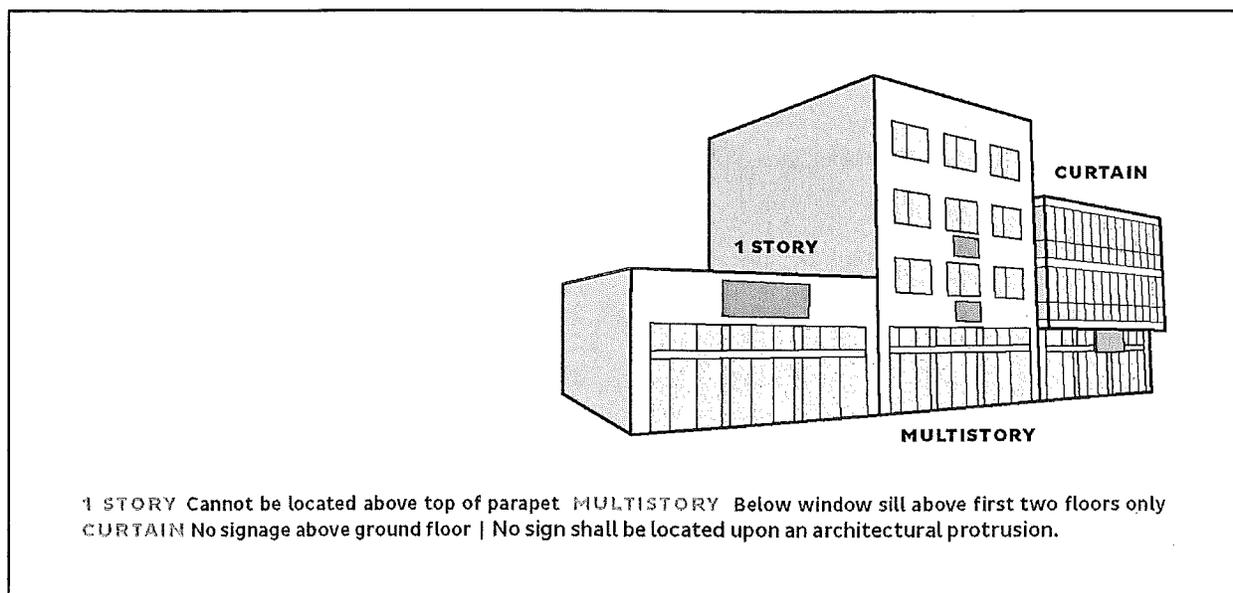

Figure 44-4. Locations of a wall sign.

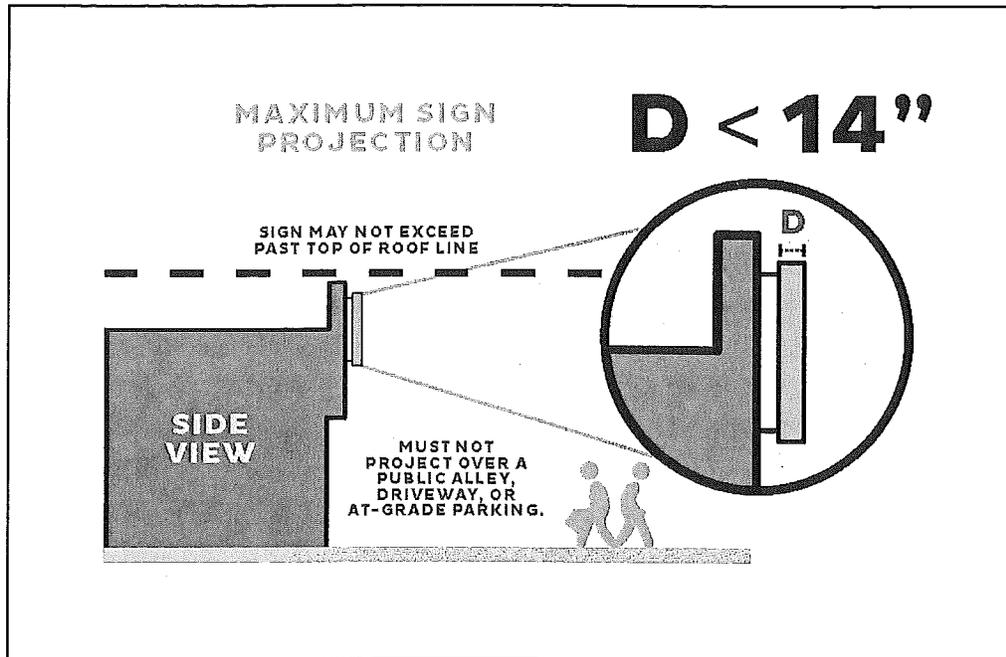

Figure 44-5. Maximum projection of a wall sign.

- E. **Projection.** The maximum projection shall be fourteen inches (14"). No wall sign shall project over a public alley, driveway, or parking above grade. See Figure 44-5.
- F. **Design.** The following design standards shall apply to all wall signs:
1. **Channel letters preferred.** Signs consisting of individual channel letters are strongly preferred. Exposed raceways are prohibited unless necessitated by structural considerations.
 2. **Foam letters.** Foam letter signs are strongly discouraged. Foam letters must be faced with a material such as plastic or metal. Un-faced foam letters (including those that are painted only) are prohibited. Wall painted signs are preferred over foam letter signs.
 3. **Cabinet signs.**
 - a. New cabinet ("can") signs are strongly discouraged, except in the case of unusually shaped signs or logos that would be onerous to render in channel letter form. Channel letter signs are preferred instead.
 - b. Existing cabinet signs may continue to be used and maintained, subject to the regulations of this Chapter. However, upon replacement of the sign face or copy, use of a "push-through" cabinet sign face shall be required, with the sign copy rendered in relief either in front of or behind the sign face. The purpose of this regulation is to obtain higher-quality sign design for the remaining lifespan of existing sign cabinets.

4. **Flat wall signs.** Wall signs consisting of copy that is painted or otherwise applied or rendered, with no surface relief, onto a background sheet product of wood (including plywood, fiberboard, etc.), plastic, or metal, which is then affixed to the building wall, shall not be permitted, unless approved through the Creative Sign Permit process, in order to ensure that the sign is of a high-quality design. The purpose of this regulation is to avoid the use of these materials in low-quality sign designs.

G. **Wall Painted Signs.** Wall painted signs are regulated in Division II – Special Major Sign Types.

21.44.130 – Projecting (blade) signs. Projecting signs (also known as blade signs), are permitted subject to the following provisions.

- A. **Number.** A business may display one projecting sign per street frontage or parking lot frontage on an adjacent property. Where freestanding signs are allowed, a projecting sign may be permitted in lieu of each freestanding sign.
- B. **Area.** The maximum area of a projecting sign shall not exceed one square foot per linear foot of building frontage from which the sign projects. For double-sided signs, sign area shall be taken from one side of the sign only. See Figure 44-6.

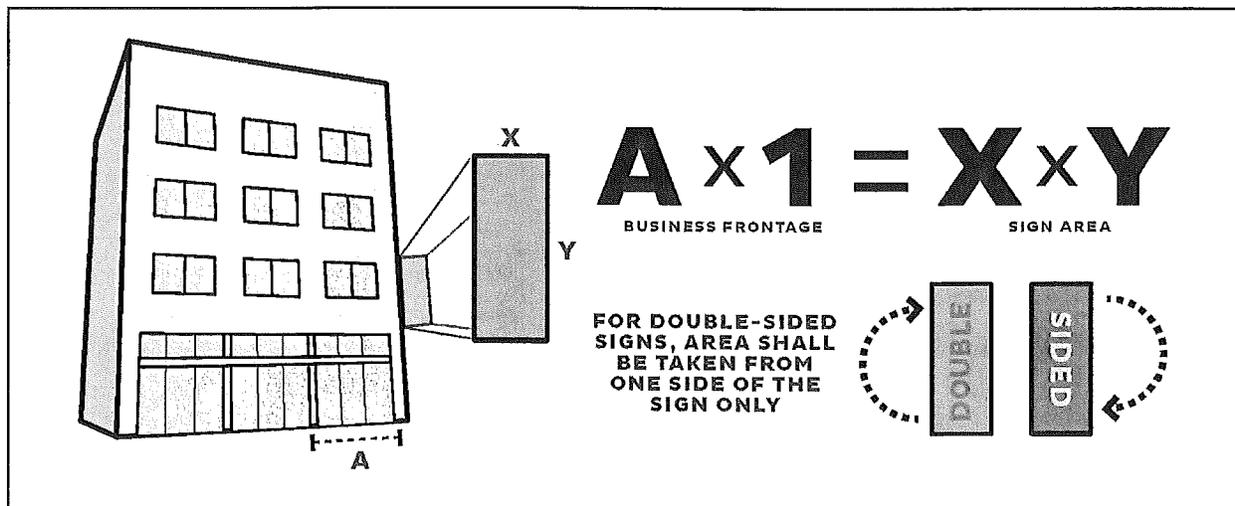

Figure 44-6. Measurement and allowable area of a projecting sign.

C. **Height.** No projecting sign shall extend above the adjacent eaves of a sloped roof. A projecting sign shall not extend more than one-third (1/3) of the sign's vertical length above the parapet line of a flat roof; or be less than eight (8) feet above the grade of the adjoining pedestrian right-of-way. A projecting sign shall be exempt from the building height limits of the zoning district.

D. **Location.**

1. Projecting signs shall be attached to a building, and not a pole or other structure.
2. For buildings with multiple businesses, multiple projecting signs shall be separated by at least twenty-five (25) feet, and only one projecting sign may be located on each building corner. See Figure 44-7.
3. If any portion of a projecting sign is located above a second floor windowsill line, it shall be located a distance away from any such window(s) equal to twice the projection of the sign from the wall in which the window is located, unless the building has a glass curtain wall system.
4. For a building located on a corner lot, the projecting sign is encouraged to be located on the corner or face of the building on the street corner. A vertical projecting sign on a building corner should be mounted at a 45-degree horizontal angle so that its two sides are equally visible from both streets.

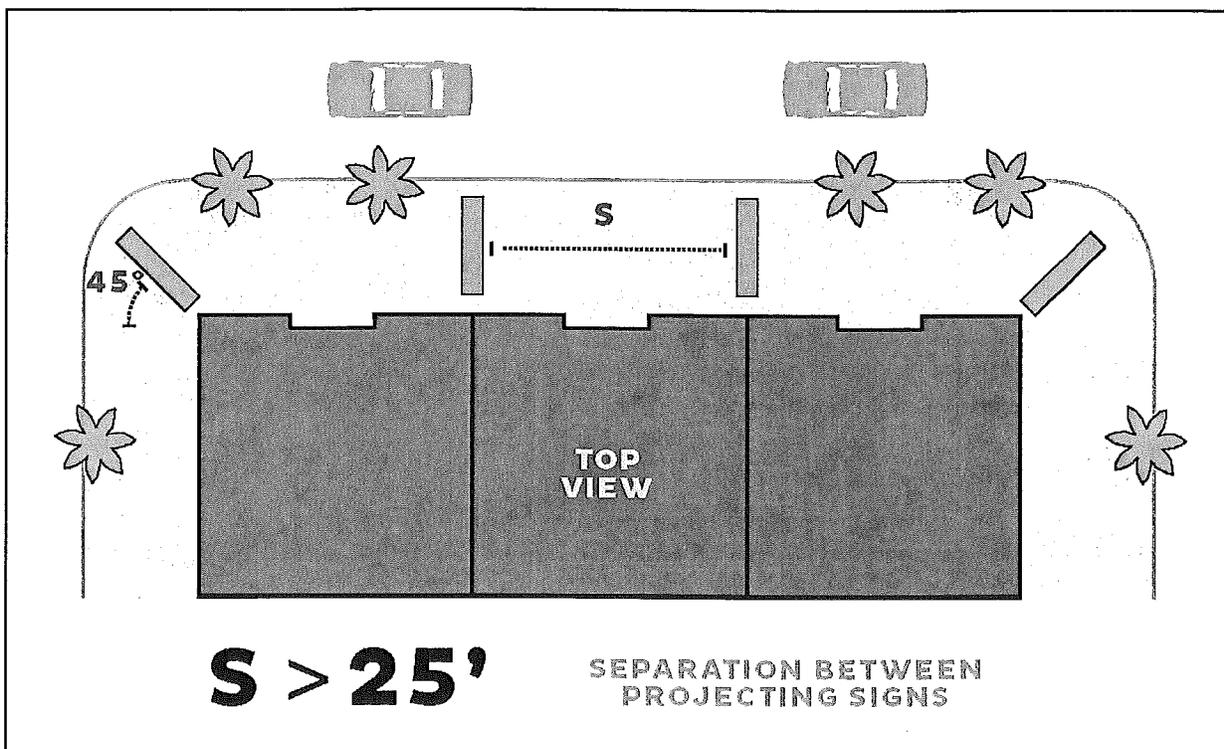

Figure 44-7. Required separation between projecting signs.

E. Projection.

1. No projecting sign shall project more than four (4) feet from the face of the building wall upon which the sign is mounted. If such sign projects into the public right-of-way, then an encroachment permit must be obtained from the Department of Public Works. See Figure 44-8.

2. No sign may project closer than two (2) feet to the curb line.
3. No sign may project over a public alley.

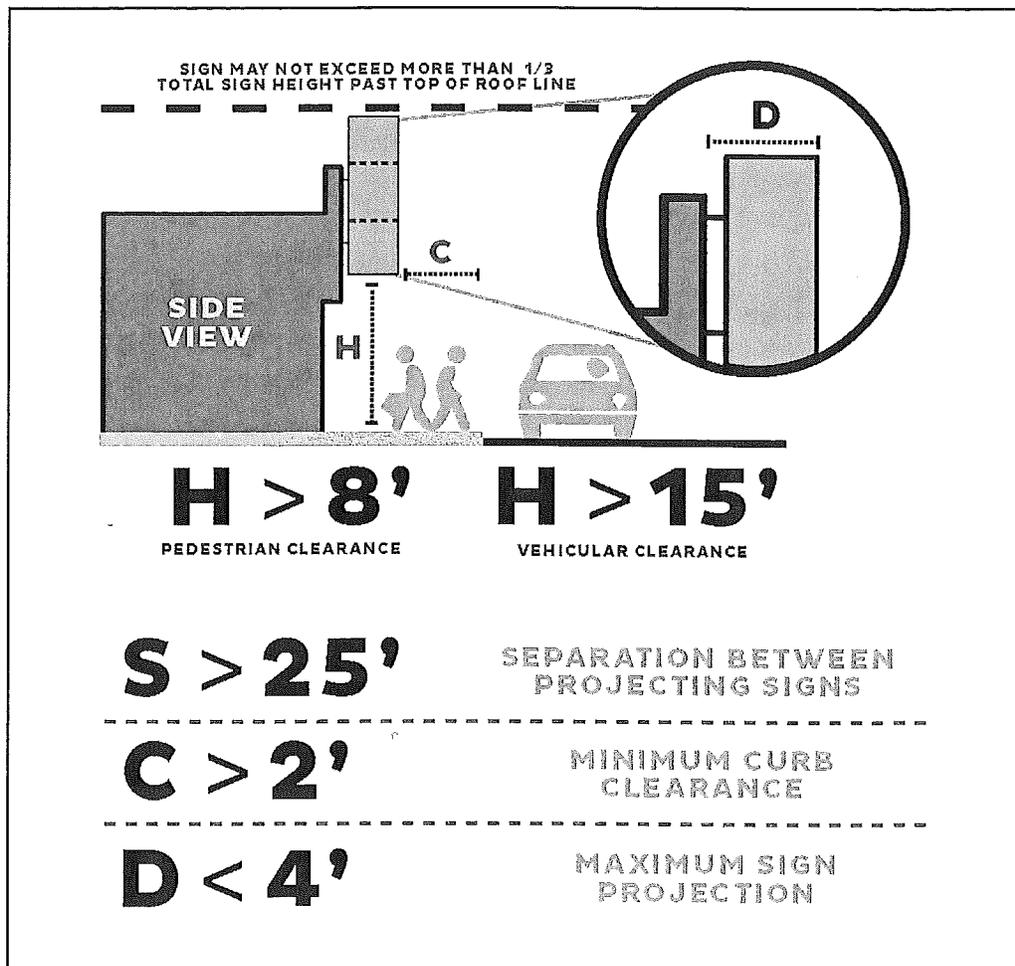

Figure 44-8. Projection and required clearance of a projecting sign.

- F. **Design.** The following design standards shall apply to all projecting signs:
1. Individual channel letters on a background are preferred.
 2. Plastic-faced cabinet signs are prohibited for use as projecting signs. However, other internally illuminated sign types, such as reverse-channel letter signs, are suitable for use as projecting signs.
 3. Projecting signs shall be constructed of high-quality, durable materials and shall be of a permanent nature.
- G. **Building permit required.** No sign permit shall be issued for a projecting sign unless a building permit also is obtained. The purpose of this requirement is to prohibit temporary, flimsy, fragile, or other projecting signs of a less-than-permanent nature that would not require a building permit for attachment to a building.

- H. **Supporting Device.** Guy wires may be used for lateral support when fully within the horizontal plane of the sign. Any angle iron or secondary support, other than guy wires, must be enclosed in a form constructed of impermeable material so as not to be visible.

21.44.140 Freestanding/monument signs. Any self-supporting permanent on-premises sign that is not attached to a building is either a freestanding sign (see Section 21.15.2580), or a monument sign (see Section 21.15.2620). Table 44-1 sets forth the zoning districts in which freestanding and monument signs are allowed. Freestanding and monument signs are permitted subject to the following provisions:

A. **Number.**

1. **Individual Businesses or Shopping Centers.** Any individual business or a shopping center may display one freestanding/monument sign on a property. For each length of street frontage in excess of three hundred (300) feet, a business or group of businesses may display one additional freestanding/monument sign for each additional three hundred (300) feet, or portion thereof, of street frontage abutting the developed portion of the property occupied by the businesses.
2. **Automobile Service Station.** In addition to other signs, an automobile service station may display one freestanding/monument sign per street frontage for the display of fuel prices.

B. **Area.** The permitted area of freestanding/monument signs shall be as provided in Table 44-2. No sign shall be permitted to exceed the maximum area indicated, regardless of street frontage.

C. **Height.** The maximum permitted height of a freestanding/monument sign shall not exceed the limits set forth in Table 44-2. The height of a freestanding/monument sign is measured from grade to the highest point of the sign, except that the height of the freeway-oriented freestanding signs, where the freeway elevation is greater than the base of the sign, may be measured from the grade of the freeway lane nearest the sign not including on and off ramps to the highest point of the sign, as illustrated in Figure 44-9.

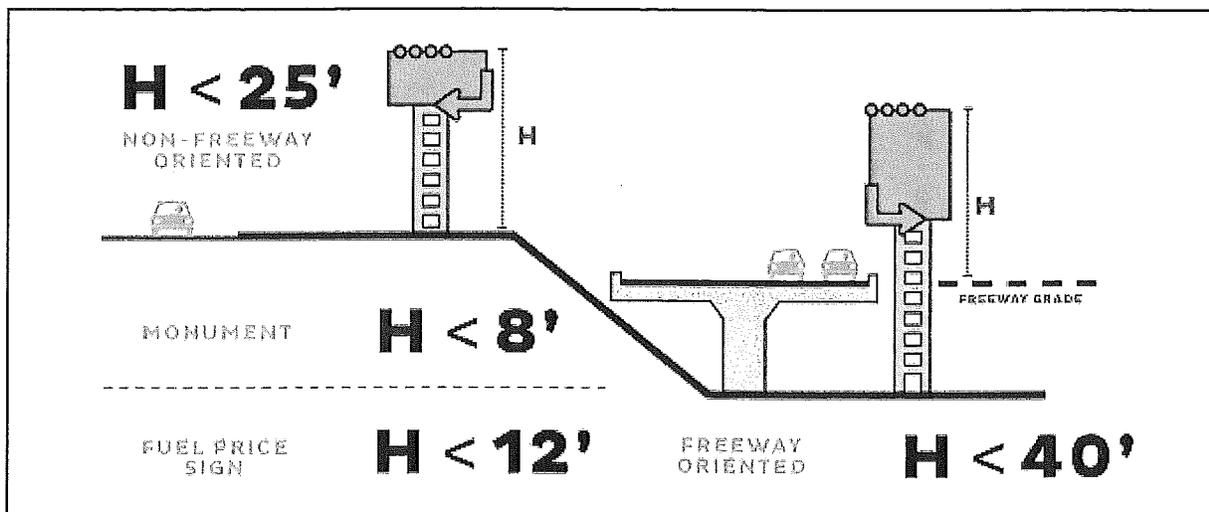

Figure 44-9. Maximum heights of freestanding signs.

D. Location.

1. No freestanding/monument sign shall be located in such a manner that it blocks, obscures, or obstructs existing signs, or signable area, on any building, including buildings on abutting property, nor shall any freestanding/monument sign be located in such a manner that it blocks, obscures, or obstructs another freestanding/monument sign, including one on abutting property.
2. Where more than one freestanding sign is used for one business or group of businesses, the minimum distance between two (2) freestanding signs on the same property shall be one hundred (100) feet.
3. No freestanding/monument sign shall be located within the required corner cut-off area of a driveway, alley, or street, as defined in Section 21.15.660 and illustrated in Figure 15-4.
4. A freeway-oriented freestanding sign must be located within one thousand five hundred (1,500) feet of the intersection of the freeway off-ramp with the surface street providing access to the premises on which the sign is located.

E. **Projection and overhang.** No freestanding sign shall overhang the property line adjoining a public right-of-way unless approval has been granted by the Department of Public Works. In any case, no freestanding sign shall project closer than two (2) feet to the curb line. Neither shall any freestanding sign shall overhang the property line between parcels.

F. **Design.** The following design standards shall apply to all freestanding/monument signs:

1. New plastic sign faces on sign cabinets for freestanding/monument signs are prohibited, except for "push-through/through-the-face" types. The

portion of a sign cabinet identifying individual tenants may consist of an internally-illuminated cabinet with individual plastic faceplates for each tenant; however, these faceplates shall be push-through/through-the-face types whenever feasible. All tenant faceplates shall be of a harmonious theme, with complementary lettering, design, and colors.

2. Freestanding signs should be architectural in nature. The slab-monolith type is encouraged, or alternately a slab with an architectural base, middle, and capital; other architectural designs can be acceptable also. Freestanding signs mounted on one or several bare poles are prohibited.
3. If a freestanding sign is not a slab-type, its support shall be at least half the width of the sign portion and shall be enclosed in an interesting architectural element that complements the sign structure and adjacent building(s). Uncovered structural poles are prohibited.
4. Individual channel letters on a background, reverse channel letters, or push-through/through-the-face designs are preferred, both for the main sign and the identification of tenants.
5. Any angle iron or secondary support shall be enclosed in a form constructed of impermeable material, such that the angle iron or secondary support is not visible.

**Table 44-2
Permitted Size, Max. Area, and Max. Height of Freestanding/Monument Signs**

Type of Freestanding/Monument Sign and Orientation	Permitted Area ^(a)	Maximum Area	Maximum Height
Freestanding sign			
Freeway-oriented ^(b)	3 sq. ft./L.F. frontage	300 sq. ft.	40 ft.
Non-freeway oriented	2 sq. ft./L.F. frontage	150 sq. ft.	25 ft.
Monument sign			
Fuel price sign (gas stations only)	15 sq. ft. ^(c)	15 sq. ft. ^(c)	12 ft.
(a) Square feet of sign area permitted per linear foot of frontage along the abutting street. (b) See location requirement in Section 21.44.140(D)(4) (c) In addition to the permitted freestanding sign, a price sign is also permitted.			

21.44.160 Awning (or marquee or canopy) signs. Awning and marquee/canopy signs are permitted for each business located on the ground floor and abutting a street, parking lot or public walkway within a mall, excluding alleys and serviceways. Each awning or marquee/canopy may display one sign subject to the following provisions:

- A. **Area.** The area of the sign may not exceed forty percent (40%) of the total face of the awning or marquee/canopy, not to exceed one hundred (100)

- square feet. The face of the awning shall be measured as shown in Figure 44-10.
- B. **Projection.** The sign may not project closer than two (2) feet to the curb line. Any encroachment over public property shall require approval from the Department of Public Works.
 - C. **Limits.** Marquee/canopy signs shall be contained entirely within the perimeter of the fascia of the marquee or canopy.
 - D. **Slope.** The face of the marquee, canopy or awning shall slope not more than sixty degrees (60°) from the vertical plane.
 - E. **Additional under-mounted signs.** In addition to a surface-mounted marquee/canopy sign, a sign which displays the business name only may be mounted on the under surface of the marquee or canopy, provided:
 1. The area of the sign does not exceed eight (8) square feet;
 2. The clearance from grade is eight (8) feet for pedestrian use and fifteen (15) feet for vehicular use; and
 3. The signs are mounted perpendicular to the building wall.

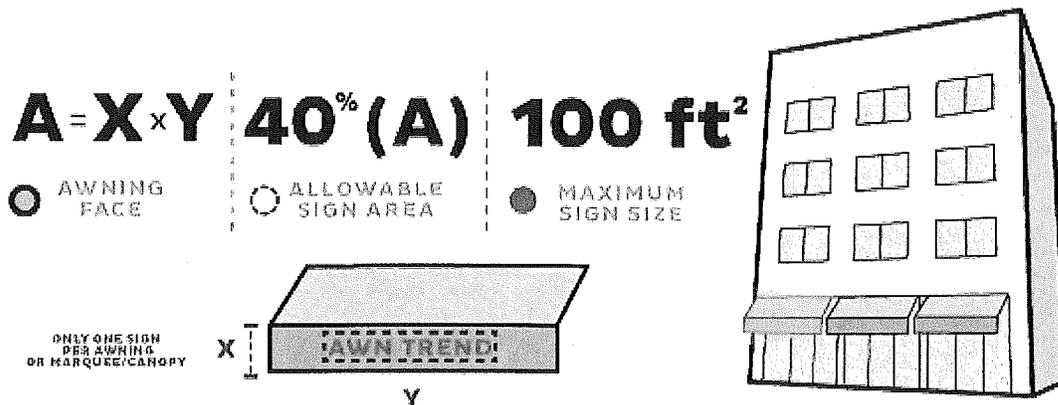

Figure 44-10. Maximum size and area measurement of an awning sign.

21.44.170 Building identification signs (commercial and residential).

- A. **Commercial Buildings.** Commercial building identification signs in the form of a wall sign or a projecting sign may be displayed on any building that is composed of one or more businesses and is at least four (4) stories high.
 1. **Number.** One building identification sign is permitted per building face/wall and shall be comprised of the business/building name and/or logo. If a projecting sign is used as the building identification sign, no other projecting sign shall be allowed for that building face, and no freestanding sign shall be allowed on the site.

2. **Area.** Commercial building identification signs shall not exceed one and one-half (1½) square feet of sign area per every linear foot of building wall and shall not exceed a maximum of three hundred (300) square feet.
 3. **Placement.** No commercial building identification sign shall extend beyond the perimeter of the signable wall area on which it is placed, nor shall it be displayed above the peak of the roof or the top of the parapet of a building, or below the lower one-third (1/3) of a building on which it is placed, unless a Creative Sign Permit is approved.
 4. **Projection.** The maximum projection shall be fourteen inches (14') from the face of the wall. Any building identification sign projecting over the right-of-way shall require approval from the Director of Public Works.
- B. Multifamily Residential Building Identification.** Multifamily building identification signs are permitted in the form of a wall sign, a monument sign, an awning or a marquee/canopy sign, or a projecting sign, subject to the following restrictions:
1. **Number.** One sign is permitted for each street the building abuts.
 2. **Design Standards.** The manner in which building identification signs may be displayed shall determine the design standards.
 - a. **Wall Sign.** The identification sign shall comply with all applicable wall sign provisions of this Chapter, except that the total area shall not exceed twenty percent (20%) of the signable area, nor more than five percent (5%) of the building face.
 - b. **Monument Sign.** The building identification sign shall comply with all applicable monument sign provisions of this Chapter, except that the maximum area shall not exceed twenty-seven (27) square feet and the maximum height above grade shall not exceed four (4) feet above grade.
 - c. **Awning or Marquee/Canopy Sign.** The identification sign shall comply with all applicable awning or marquee/canopy sign provisions of this Chapter.
 - d. **Projecting Sign.** The identification sign shall comply with all applicable projecting sign provisions of this Chapter, except that the maximum area shall not exceed twenty-seven (27) square feet.

Division II – Special Major Signs

21.44.200 – Development Standards—Special major signs. Wall painted signs, roof signs, changeable copy signs, residential neighborhood and commercial district identification signs, and historic signs shall all be considered special major signs. These sign types occur less frequently throughout the City and require specific regulation to ensure compatible design with surrounding architecture, signs, and land uses, to ensure that the City's aesthetic goals are achieved.

21.44.210 – Wall-painted signs. A wall-painted sign is intended to take the place of a wall sign, and is painted directly onto the building wall. Wall-painted signs fill an important niche in the sign types this Chapter makes available to the public—they can be established with no building permit or structural review required, at considerably less cost than a permanent wall sign. This is advantageous to small businesses just starting out, and others in similar situations. Wall painted signs also have the potential to make a significant character-enhancing contribution to their immediate surroundings and neighborhood, becoming something of a landmark if well executed. For these reasons, wall-painted signs are preferred over foam letter wall signs in the gamut of low-cost sign types.

- A. **Number, height, location and copy.** Standards for the number, height, location, and copy of wall-painted signs shall be the same as for wall signs, as specified in this Chapter.
- B. **Area.** In order to encourage the selection of a wall-painted sign over foam letters or other low-cost sign types, the allowable area is increased such that wall-painted signs shall not exceed one and one-half (1½) square feet of sign area per every linear foot of building wall and shall not exceed a maximum of one hundred (100) square feet on any sign facing a residential, local or collector street, and not more than two hundred fifty (250) square feet for any sign facing a major or minor arterial.
- C. **Review.** In order to assure a quality design for each wall-painted sign, the wall-painted sign application shall be reviewed by the Site Plan Review Committee, or a sub-committee designated by the SPR Committee for this purpose, within three weeks of filing, at no fee to the applicant. The SPR Committee shall either approve the application, or direct the applicant to alter the plans in a way that would allow the Committee to approve the application.

21.44.220 – Roof signs. Roof signs shall be permitted through the Creative Sign Permit process only. The area standards for projecting signs shall apply to roof signs. The building height limits established for the zoning districts shall not apply to roof signs.

21.44.230 – Changeable copy signs. Changeable copy signs shall be allowed subject to the following:

- A. **Users limited.** Changeable copy signs are limited to the following users: churches, florists, public schools, public colleges and universities, movie theaters, and gasoline price signs for gas stations. Exceptions to this rule shall require a Standards Variance as described in Division V of Chapter 21.25—Specific Procedures.
- B. **Size.** Changeable copy displays may be installed on freestanding, monument, and wall signs. The area of the changeable copy display shall be counted toward the allowable sign area for the type of sign upon which the changeable copy is installed.

21.44.240 – Residential neighborhood and commercial district identification signs. The City recognizes the desire for unique communities within its boundaries, both residential and commercial, to positively identify themselves and their geographic boundaries. To this end, the following guidelines are established to control the design, content, and location of such identification signs on both private and public property. In addition to these standards, the provisions of Section 21.44.900.A.6 (Signs on public property) also shall apply to any such sign located on public property. Street-name-style Neighborhood Marker Signs mounted on street lights or traffic signal poles are not regulated by this Chapter, and are administered by the Department of Public Works.

- A. **Type of Sign.** Limited to monument signs for residential neighborhood identification. Monument or freestanding signs are allowed for commercial district identification.
- B. **Number of Signs.** Each residential neighborhood or commercial district shall display no more than one sign on each side, or corner, or boundary of the neighborhood or district. In cases of irregularly-shaped or unclear boundaries, the Zoning Administrator shall be authorized to determine if a given proposal conforms to this regulation.
- C. **Maximum Height, Width, and Area.** The maximum height, width, and area allowed for residential neighborhood and commercial district identification signs shall be as provided in Table 44-3.

**Table 44-3
Height, Width, and Area Development Standards for Residential Neighborhood and Commercial District Identification Signs**

Type of sign	Maximum Height (ft.)	Maximum Width (ft.)	Maximum Area (sq. ft.)
Monument	4	9	36
Freestanding	15	4	32

- D. **Thickness.** Minimum of three inches (3”) to a maximum of one foot (1’).
- E. **Materials.** Wood, stone, concrete, stucco, or metal or a combination of these materials.
- F. **Lettering.** Individual letters carved from display or bolted onto display. Fragile or glued-on lettering is prohibited.
- G. **Lighting.** Exterior light sources or internal illumination are allowed. External lights shall be aimed and shielded to prevent any light trespass into the adjacent roadway or adjacent properties.
- H. **Prohibited.** Cabinet signs are prohibited as residential neighborhood and commercial district identification signs, as well as any plastic or fabric panels or fascia.
- I. **Identification.** Each sign must indicate that the respective neighborhood or commercial district is part of the City of Long Beach, using the name “City of Long Beach” in at least 3-inch-tall letters. The purpose of this regulation is to avoid giving the impression that an area is a separate city or otherwise not a member of the City as a whole.
- J. **Site Plan Review required.** Prior to the issuance of a sign permit (and prior to issuance of a right-of-way permit by the Department of Public Works in the case of a sign located on public property), an identification sign for a residential neighborhood or commercial district shall be subject to review by the Site Plan Review Committee. A fee equivalent to the fee for a Creative Sign Permit, as specified in a fee resolution to be adopted by the City Council, shall be required.
- K. **Waiver of standards.** The Site Plan Review Committee may, at its discretion, waive the following development standards: type of sign, number of signs, height, length, thickness, materials, and lettering. The Site Plan Review Committee shall approve such waivers only if the findings required for a Creative Sign Permit are made, and the waiver will achieve the specified purpose of a Creative Sign Permit. However, prohibited sign types and materials shall not be approved through a waiver.

21.44.250 – Historic signs. Any sign designated by City ordinance as a Historic Landmark, or granted historic designation by the California State Historic Preservation Office, or the United States Secretary of the Interior, or any sign that is a historic element of such a designated building or site, shall be considered a historic sign. Historic signs shall be exempt from the requirements of this Chapter as to height, illumination, location, movement, sign area, and materials, and may be maintained as legally conforming signs subject to the following conditions.

- A. All parts of the exempted historic sign including neon tubes, incandescent lights and shields, and sign faces shall be maintained in a functioning condition as historically intended for the sign to the greatest degree possible.
- B. Parts of historic signs originally designed to flash or move may be allowed to continue to flash or move. There shall be no alterations to the historic pattern, speed, or direction of flashing or moving elements.
- C. The wording or image of a historic sign may be altered only if the alterations do not substantially change the historic dimensions, height, scale, style, character, or type of materials of the historic sign.
- D. Failure to maintain a historic sign as required above shall be grounds for disallowing an exemption from the requirements of this Chapter. The Cultural Heritage Commission shall be authorized to make a determination of revocation of exemption. The sign shall thereafter be brought into compliance with the requirements of this Chapter to the satisfaction of the Director of Development Services.
- E. Full reconstruction or major alteration of a historic sign shall require approval of the Site Plan Review Committee, and the Cultural Heritage Commission in the case of a City-designated Historic Landmark.

Division III – Minor Signs

21.44.300 – Development standards—Minor signs. Menu boards, on-site directional signs, and traffic directional signs shall be considered minor signs subject to the development standards outlined in this Division.

21.44.310 – Menu boards. Menu boards are permitted for drive-through fast food restaurants subject to the following restrictions:

- A. **Number.** In addition to other permitted signs, two freestanding menu boards and one wall sign are permitted for each automobile service window.
- B. **Area.** Menu boards shall not contain more than forty (40) square feet in area.
- C. **Height.** Menu boards shall not exceed seven (7) feet in height above grade.
- D. **Copy.** Menu boards shall contain only the business name, and information related to the food items and prices. The maximum letter size shall be three inches (3”).
- E. **Orientation and location.** Each sign shall be oriented to customers on the site, and not toward the adjacent right-of-way. The purpose of these signs is to provide information to customers already on site, and not passers-by. Signs shall not be located within the required corner cutoff areas at driveway or drive-through entrances/exits.

21.44.320 – On-site directional signs. On-site directional signs are permitted at business and institutional sites, for the purpose of directing persons to destinations within the site, subject to the following restrictions. They are intended primarily for land uses with larger parking lots, and/or drive-thru lanes.

- A. **Number.** In addition to other permitted signs, a business or site may display up to four (4) on-site directional signs by right. If a business or site wishes to display five (5) or more on-site directional signs, a Sign Program shall be required.
- B. **Area.** On-site directional signs shall not be more than sixteen (16) square feet in area.
- C. **Height.** On-site directional signs shall not exceed four (4) feet in height above grade.
- D. **Copy.** On-site directional signs shall contain only words such as “Drive-through” (or “Drive-thru”), “Enter,” “Exit,” “This Way,” and “Do Not Enter,” as well as the business name and/or logo. The maximum letter size shall be three inches (3”).
- E. **Orientation.** On-site directional signs shall be oriented toward on-site traffic, and not toward the adjacent right-of-way. The purpose of these signs is to provide direction to traffic already on site, and not to traffic on the adjacent

right-of-way. Signs shall not be located within the required corner cutoff areas at driveway or drive-through entrances/exits.

21.44.330 – Traffic directional signs. Traffic directional signs, either wall or freestanding, may be displayed as necessary for all land uses to ensure the safe and orderly flow of automobile traffic on private property.

- A. **Copy.** Traffic directional signs are limited to non-commercial messages for the purposes of directing safe flow of automobile traffic. A traffic directional sign shall not provide directions to a particular business, location, or event. Traffic directional signs shall be limited to stop signs, one-way signs, do not enter signs, speed limit signs, left/right turn only signs, no left/right turn signs, and other traffic signs of like purpose.
- B. **Area and Size.** Each sign shall have a maximum area of six (6) square feet, and a maximum height of seven (7) feet, unless waived by the Zoning Administrator upon the recommendation of the City Traffic Engineer.
- C. **Interference with Official Traffic Control Devices.** No traffic directional sign shall interfere with any official public traffic control device. Any traffic directional sign that is found to do so shall be removed or remedied by the property owner upon order by the City Traffic Engineer.
- D. **Conformance with Traffic Control Device Standards.** All traffic directional signs shall be in conformance with the national, state, and local standards for traffic control devices in effect in the City of Long Beach to the satisfaction of the City Traffic Engineer.

Division IV – Temporary Signs

21.44.400 – Temporary signs. Certain classes of signs may be erected as temporary signs subject to the following regulations.

21.44.410 – Promotional activity signs (banners). Promotional activity signs, as defined in Section 21.15.2720 of this Title, are permitted, subject to the following:

- A. **Area.** A promotional activity sign (banner) shall not exceed one square foot of banner area for each linear foot of building street frontage and shall not exceed one hundred (100) square feet, whichever is less.
- B. **Number.** Only one (1) promotional activity sign shall be allowed per street frontage, or per business in the case of a commercial building with multiple business tenants.
- C. **Aspect ratio.** A promotional activity sign shall not have an aspect ratio exceeding 3.0 (3 units length per 1 unit height).
- D. **Location.** Promotional activity signs shall be placed on a building wall only. It shall be prohibited to place a promotional activity sign on a fence, supported from poles or trees, between buildings or walls, upon an existing sign cabinet or structure (whether in use or not), on a building roof or extending above the parapet wall, or upon another structure. Promotional activity signs shall not be placed overhanging or obscuring windows.
- E. **Time Limit.** The following time limits shall apply to promotional activity signs:
 - 1. A promotional activity sign permit shall be valid for only ninety (90) days and shall not be renewable in the same calendar year.
 - 2. The allowed time period shall be measured in calendar days. The 90-day period may be broken into two 45-day periods or three 30-day periods, provided that the sign is removed at the end of each period.
 - 3. If the 90 days includes December 31 and January 1, the permit shall be prorated or adjusted accordingly, such that permits are not issued for a site for more than 90 days in a given calendar year, including prior promotional activity sign permits having a portion of the 90 days period in the same year.
- F. **Legalization of promotional activity signs (banners) without permits.** Any promotional activity sign placed without a valid permit shall be subject to the following:
 - 1. If a permit is to be issued, the applicant shall pay double fees;
 - 2. The duration (in days) that the sign was in place without a permit shall be subtracted from the 90 days allowed for a promotional activity sign if it is to be legalized through a permit;

3. If the sign was in place for 90 days or more without a permit, the sign shall be removed and no permit shall be issued for the subject location in that calendar year; and
4. If the duration that the sign was in place without a permit is not known or is not divulged by the applicant, the sign shall be assumed to have been in place for 90 days, and the sign shall be removed, and no promotional activity sign permit shall be issued for the subject location in that calendar year.

G. Exceptions.

1. **Real estate signs and banners.** Real estate signs and banners are considered “permit exempt” signs and are subject to the restrictions specified in Table 44-4.
 2. **Grand opening signs.** One promotional activity sign for a grand opening event shall be allowed for a period of ninety (90) days in a calendar year, in addition to one other promotional activity sign in the same calendar year.
 3. **Automobile sales businesses/dealerships.** Vehicle sales businesses may be exempted from the limitations of this Section on promotional activity signs through the Creative Sign Permit process; except that all pennants, streamers, and inflatable, air-blown, balloon-type and all other prohibited signs or decorations shall be prohibited regardless.
 4. **Non-commercial promotional activity signs.** Non-commercial promotional activity signs are considered permit exempt signs and are subject to the restrictions specified in Table 44-3.
- H. Street Banners.** Street banners and banners hung across a public street are subject to approval by the City Manager as provided in Section 18.56.050 of the Municipal Code, and are not regulated by this Chapter.
- I. Maintenance.** Promotional signs shall not be in a condition of disrepair. Disrepair shall include torn, faded, sagging, or dirty signs, and signs with a message that is outdated or no longer relevant. Signs in disrepair shall be removed, or may be restored or repaired if still within the permitted 90-day period.

21.44.420 – Political signs. Political campaign signs are not regulated as a separate class of signs.

21.44.430 – Subdivision signs. Subdivision signs advertising the initial sale or lease of residential units within a single contiguous grouping comprised of fifteen or more dwelling units, or fifteen or more lots, are permitted, subject to the following regulations:

- A. **Display Period.** A subdivision sign may be displayed during the period of construction and for a period not to exceed six months from the date which eighty percent of the units have received certificate of occupancy, or until all of the units or lots have been sold or leased, whichever occurs first.
- B. **Permitted Sign Types.** Only non-illuminated, freestanding signs are permitted.
- C. **Number.** One sign is allowed, plus one additional sign for each fifty dwelling units or lots in the subdivision, or one plus one for each five acres in the subdivision, whichever is less.
- D. **Sign Area and Height.** The size of a subdivision sign shall not exceed two hundred (200) square feet, and the height shall not exceed fifteen (15) feet, measured from grade to the highest point of signs.

Division V – Permit Exempt Signs

21.44.500 – Permit exempt signs. The classes of signs set forth in this Section are exempt from the application, permit and fee requirements for on-premises signs, provided the exempt sign conforms to Table 44-4—Exempt Signs. This Section shall not exempt such signs from other provisions of the Municipal Code, including but not limited to those that may require building or electrical permits.

**Table 44-4
Permit Exempt Signs**

Class of Sign	Maximum Size	Maximum Number	Other Conditions
1. Building directory sign identifying building occupants	18 sq. ft.	1 per parking lot entry and building entry	–If changeable copy used, must be glass encased –Must be visible from sidewalk or parking lot
2. Interior signs	Area of sign must be less than 25% of total area of window through which it is exhibited	3 per window	–Must be located between 1 foot to 6 feet to the interior of any window from which sign is visible –Sign may not flash, rotate or exhibit any other prohibited characteristics
3. Public service and accessory signs identifying public conveniences (e.g., restrooms, telephones, hours of operation, vacancies)	Total area of all signs visible from any one street shall not exceed 10 sq. ft.	One per service, accessory, or convenience per street frontage	None
4. Theater outer lobby posters advertising current or coming attractions	20 sq. ft. per poster	2 posters per movie screen, per street frontage	Must be glass encased
5. Window signs	Total of all signs displayed in any one window may not cover more than 10% of total window area	1 sign per 3 linear feet of window	–Each window shall be calculated separately. –Must be placed in such a manner so as to not obstruct visibility into business.
6. Any other non-prohibited sign, if less than 3 sq. ft.	Less than 3 sq. ft.	1 sign per 10 linear feet of building frontage facing street(s)	No sign shall be placed in the public right-of-way or on vacant property.

Class of Sign	Maximum Size	Maximum Number	Other Conditions
7. Construction sign identifying firms involved in construction site, future tenants, or announcing development	Height—15 ft. Area—16 sq. ft.	1 per street abutting construction site	–Must be removed within 15 days of completion of construction –No illumination permitted
8. Flags	Length—9 ft. Width—6 ft.	3 flags	–Flag pole height shall be limited to the established building height for each respective zoning district. –Flag signs are prohibited, as defined in Section 21.15.2510. –Decorative flags are prohibited; see Section 21.44.600.
9. Garage sale signs	Height—4 ft. Area—6 sq. ft.	1 per garage sale on same premises	No sign shall be placed on public property.
10. Open house signs or flags/banners	Height—4 ft. Area—6 sq. ft.	1 per 300 feet of street frontage	–May be used on temporary basis only when house is open for inspection without an appointment –May not be placed on public property
11. Real estate signs (on-premises) advertising sale, rental or lease of property	Height—8 ft. Area— a) Non-residential use—16 sq. ft. b) Residential use—6 sq. ft. for first dwelling unit plus 1 sq. ft. for each additional unit up to 16 sq. ft. maximum	1 per 300 feet of street frontage	–Types limited to non-illuminated wall, window, or freestanding signs –No signs may be placed on public property –Signs may be displayed only during the period the premises is held for sale, rental or lease, and for not more than 15 days thereafter –Signs must be maintained in good condition.
12. Real estate banners	Height—same limitations as wall signs Area—16 sq. ft., or 6 sq. ft. plus 1 sq. ft. for each additional unit, whichever is less Aspect Ratio—maximum aspect ratio of 3.0 (3 units length to 1 unit height)	1 banner in addition to 1 other real estate sign per 300 feet of street frontage	–Banners must be placed on a building wall and may not be mounted on poles, fences, above the roof deck/roof line, etc. –Banners may be displayed only during the period the premises is held for sale, rental or lease, and for not more than 15 days thereafter –Banners must be maintained in good condition, with current information, and must be replaced when worn or dilapidated.
13. Single-family residential sign identifying resident	Not to exceed 2 sq. ft.	1 per residence	None
14. Warning signs (e.g., “Danger,” “No Dumping”)	3 sq. ft. per warning	As necessary per warning	None

Class of Sign	Maximum Size	Maximum Number	Other Conditions
15. Street address signs	No maximum if sign contains address only	1 per address per street frontage	Minimum letter height of 4 inches
16. Signs painted on parking lot surface	½ width of drive aisle	As necessary	Must contain parking or directional information only and no commercial message
17. Non-commercial promotional activity signs	16 sq. ft per sign; not to exceed a maximum total area of 80 sq. ft. for all such signs on a lot or parcel whether such lot is zoned commercial, residential or industrial.	No limit on the number of signs provided the maximum area of 80 sq. ft. for each lot or parcel is not exceeded.	Signs shall not interfere with or be designed in such a manner that they will be confused with a traffic control signal or sign, or obstruct the vision of traffic. They shall not be placed on any public property or right of way or posted on any utility pole or device. Signs shall be removed from a premise no later than 5 days following the conclusion of the activity or event promoted by such sign.
Abbreviations: sq. ft. = square feet ft. = feet			

Division VI – Prohibited Signs

21.44.600 – Prohibited signs. The following signs shall be prohibited:

- A. **Unlawful Sign Projections.** No sign shall project into an adjoining private property under separate ownership, or into a public right-of-way or into an established setback unless an encroachment permit has been issued by the City Engineer.
- B. **Flashing Signs.** No sign shall flash, shimmer or glitter, nor give the appearance of flashing, shimmering or glittering.
- C. **Moving or Rotating Signs.** No sign shall rotate, oscillate or otherwise move, nor give the appearance of rotating, oscillating or moving.
- D. **Sound, Odor, Particulate Matter.** No sign shall emit audible sound, odor or particulate matter.
- E. **Unlawful Illumination.**
 - 1. No sign illumination system shall contain or use any beacon, spot, or stroboscopic light, or reflector which is visible from any public right-of-way or adjacent property.
 - 2. Generally, illuminated signs shall not be allowed to change color or light intensity. The exception being neon, fiber optic, or light-emitting diode (LED) light sources, which are permitted to gradually change color. Light intensity shall not be allowed to change.
 - 3. No floodlight shall be used which is not hooded or shielded so that the light source is not visible from any public right-of-way, adjacent property, or residential dwelling unit.
- F. **Portable Signs.** Portable signs are prohibited, except that a portable sign may be displayed to indicate a temporarily closed vehicular entrance or exit for purposes of public safety or convenience.
- G. **Street Furniture.** Signs shall not be placed on street furniture, as defined in this Title.
- H. **Vehicle Signs.** Signs identifying a business shall not be affixed to or placed in or on vehicles parked in the public right-of-way or on private property in a manner such that the vehicle functions as a sign for the business. This regulation shall not apply to buses and taxicabs legally operating within the City limits, or to other permitted uses regulated under other Titles of the Municipal Code. However, mobile billboards are prohibited in Chapter 21.54 (Billboards).
- I. **Obstruction of Use or Visibility.** No sign shall be located so that any portion of the sign or its supports interferes with the free use of any fire escape or exit or obstructs any required fire standpipe, stairway, door, ventilator or window;

nor shall any sign be located so as to obstruct the visibility (corner cut-off areas) of vehicles or pedestrians using driveways or doorways.

- J. **Interference with Utility Lines.** No sign shall be located which has less horizontal or vertical clearance from utility lines than that prescribed by the rules of the Public Utilities Commission of the State.
- K. **Interference with Official Traffic Control Devices.** No sign shall appear in color, wording, design, location or illumination to resemble or conflict with any traffic control device.
- L. **Inflatable and Air-Blown Signs.** Any signs or decorations that are inflatable, such as balloons of any size or shape, and any signs that are air-blown or inflated or animated by the internal flow of air, such as signs that appear to have a waving body and appendages, are prohibited.
- M. **Flag Signs.** Flag signs (as defined in Section 21.15.2510) are prohibited. This includes any type of flag that functions as a sign, whether affixed to a building or not, including but not limited to those mounted on curved or flexible swivel masts and commonly referred to as “sails,” “feathers,” or “bow banners.”
- N. **Decorative flags.** Flags with no intrinsic meaning (usually, but not limited to, simple flags of one or several colors, with or without a design motif), which are intended only to draw attention to a building or location, are prohibited. However, nothing in this Subsection shall be construed to prohibit any flag that constitutes a protected form of expression and is in compliance with all other applicable provisions of the Municipal Code.
- O. **Streamers, pennants, balloons, and the like.** All types of signs and exterior decorations that can be considered streamers, pennants, balloons, and the like shall be prohibited.
- P. **Projected light signs.** Any sign created by projecting light onto a surface is prohibited.
- Q. Any sign not exempted or permitted by this Chapter shall be prohibited.

Division VII – Nonconforming, Abandoned and Illegal Signs and Other Provisions

21.44.710 – Nonconforming signs. It is the intent of this section to recognize that the eventual elimination of existing on-premises signs that do not conform to this Chapter is as important to Citywide aesthetic and health, safety and welfare as is the prohibition of new signs that would violate the provisions of this Chapter. It is also recognized that nonconforming signs should be eliminated as expeditiously and fairly as possible in a manner that avoids any unreasonable invasion of established property rights.

A. Continuation of Use. A nonconforming on-premises sign may be continued in operation and maintained after the effective date of the ordinance codified in this title, provided that nonconforming signs shall not be:

1. Changed to another nonconforming sign; or
2. Structurally altered so as to extend the useful life of the sign; or
3. Expanded; or
4. Reestablished after damage or destruction of more than fifty percent of the sign value at the time of such damage or destruction.

The copy on non-conforming signs may be changed without affecting their nonconforming status, provided the content of the new copy is consistent with the provisions of this code, and a building permit is not required to change the copy.

B. Amortization.

1. Permanent nonconforming signs shall be removed or brought into compliance with the provisions of this Chapter under the following circumstances:
 - a. Whenever the business, building, or other establishment for which the sign was emplaced is vacated, or
 - b. Whenever there is a change in the business license for the owner or lessee of a property on which there is a nonconforming sign(s), the nonconforming sign(s) shall be removed or brought into compliance with the provisions of this chapter prior to the effective date of the new owner's or lessee's business license, or
 - c. Upon approval of a building or electrical permit to modify a nonconforming sign for the purpose of expanding the sign, or structurally altering it to extend its useful life, or to reestablish the sign after damage or destruction of more than fifty percent of the sign value at the time of damage or destruction, the nonconforming sign shall be brought into compliance with the provisions of this Chapter.

2. Nonconforming wall-painted signs shall be painted out, or brought into compliance with the provisions of this Chapter when there is a change in business ownership or lessee of the property.
3. Cabinet signs with translucent plastic faces shall be subject to the requirement to utilize a push-through-type of sign face, as specified in Section 21.44.120(F)(3), upon replacement of the sign face or copy, or when the circumstances specified in Section 21.44.710(B)(1) are met.
4. Historic signs shall be exempt from amortization, as provided in Section 21.44.250.

21.44.720 – Abandoned signs. All abandoned signs, as “abandoned sign” is defined in Section 21.15.2520, shall be removed immediately.

21.44.730 – Illegal signs. All illegal signs have no vested rights and shall be removed or made to conform to the provisions of this Chapter immediately.

21.44.740 – Administrative removal of signs. Signs may be removed by the City in accordance with the following procedures:

- A. **Illegal or Dilapidated Signs.** If the Director of Development Services, or his or her designee, finds that a sign is in violation of this Chapter, or is in disrepair, defaced, deteriorated (including peeling paint), prohibited, abandoned, illegal, or is in violation of the Building Code or any other laws and ordinances, he shall seek correction of the violations as provided for in the Municipal Code, including the Administrative Citation process. The Director of Development Services shall inform the sign owner by a written notice if the sign is to be removed.
- B. **Safety Hazard or On Public Right-Of-Way.** The City Engineer, or his designee, without giving notice, shall have the authority to authorize removal of any sign which:
 1. Poses an immediate threat to public safety; or
 2. Is displayed in violation of the provisions of this Chapter or other City ordinances on or over any public right-of-way or public property.

Division VIII – Electronic Message Center Signs

21.44.800 – Electronic message center signs. Electronic message center signs (abbreviated EMCS) are permitted subject to the following standards. Any exception to these standards shall require application for a Standards Variance under the provisions of Chapter 21.25 (Specific Procedures).

21.44.810 – Conditional Use Permit required. The City recognizes that an electronic message center sign, if not carefully regulated and designed, has the potential to cause significant adverse effects upon its surrounding visual environment, and to negatively impact the perception of the environment and condition of its neighborhood. Therefore, to ensure that a process for adequate review is provided for these signs, each EMCS shall require an application for a Conditional Use Permit under the provisions of Chapter 21.25 (Specific Procedures), and additionally shall be subject to the findings specified in Section 21.52.229 – Electronic Message Center Signs (Conditional Uses). Additionally, to ensure a high-quality design, prior to a public hearing on the Conditional Use Permit the Site Plan Review Committee shall be authorized to review the design of the proposed EMCS under the provisions of Chapter 21.25 (Specific Procedures).

21.44.820 – Site requirements for electronic message center signs. Electronic message center signs are subject to the following site restrictions:

- A. **Lot or Building Minimum Size.** Electronic message center signs are allowed only at a business or shopping center or institutional use that is located upon five (5) or more acres of land. The five or more acres must consist of one contiguous group of parcels or lots, and must be held by one owner. Alternately, an EMCS may be permitted for a single building consisting of one hundred fifty thousand (150,000) square feet or more in gross floor area. Such building must be located on one contiguous parcel or group of lots and be held by one owner.
- B. **Same Site as Principal Use.** An electronic message center sign shall be located on the same parcel as the principal land use of the business or institution for which the sign is established. The sign shall not be located on a site containing only a land use or uses secondary to the primary operation of the business or institution. For example, an electronic message center sign shall not be located on a lot or parcel used for automobile storage by an automobile dealership whose primary sales operations are on a different site; nor shall an electronic message center sign be located on a lot or parcel used for parking for an institution if said institution is on a different parcel.
- C. **Zones permitted.** EMCS shall be allowed in certain zoning districts as provided in Table 44-5.

- D. **Street types permitted.** EMCS shall be allowed only on a street or highway classified as a Major Arterial, Regional Corridor, or Freeway.

21.44.830 – Number, location, spacing, form, and substitution/removal requirements. The following requirements shall apply regarding the number, spacing, and form of electronic message center signs, as well as substitution for other sign types and removal of other sign types.

- A. **Number.** One EMCS shall be allowed for each six hundred (600) feet of total street frontage on a qualifying site (the total may include street frontage more than one street for sites bounded by multiple streets).
- B. **Location.**
1. **Upon subject site.** No electronic message center sign shall be located closer to any interior side property line than twenty-five (25) feet. Lots adjoining freeway or railroad right-of-way may locate an EMCS on the property line adjoining such right-of-way.
 2. **Distance from residential.** All EMCS shall have a minimum separation of one hundred (100) feet from a residential district.
- C. **Spacing.**
1. **Between EMCS on same frontage.** A radius of three hundred (300) feet shall be required between each EMCS on the same property, on the same street frontage.
 2. **Between EMCS on different frontage.** No EMCS shall be located less than one hundred (100) feet from another EMCS on a different street frontage (for example, an EMCS on each frontage of a corner lot) on the same property or site.
 3. **Between EMCS and freestanding/monument signs.** The minimum distance required between a freestanding/monument sign and an electronic message center sign shall be one hundred (100) feet.
 4. **Between EMCS on different properties.** No EMCS shall be located less than three hundred (300) feet from another EMCS on a different property or site.
 5. **Freeway-oriented EMCS.** A radius of six hundred sixty (660) feet shall be required between all freeway-oriented electronic message center signs. For freeway-oriented EMCS, and EMCS located adjacent to other State highways, if the requirements of the California Department of Transportation (Caltrans) are more restrictive, those requirements shall control.
- D. **Sign form.** An EMCS may take the form or style of a freestanding sign, monument sign, or wall sign only. Other forms are prohibited.
- E. **Substitution for freestanding/monument signs and other sign removal.** For each EMCS to be emplaced, two (2) freestanding or monument signs, if extant, shall be removed from the subject site, on the same street frontage as the EMCS. Additional removal of other on-premises sign(s) may be required by the Planning Commission as a condition of approval.

21.44.835 – Design standards. The following design standards shall apply to electronic message center signs.

- A. Bare metal structural supports are prohibited, and shall have an architectural covering instead.
- B. A freestanding EMCS shall have an architectural base and support(s) totaling at least half the width of the sign face.
- C. Use of flat, translucent plastic or acrylic sign faces for the fixed/permanent copy shall be prohibited. Channel letters are preferred, and push-through-type faces may be used on cabinets.
- D. High-quality materials shall be used in the sign overall. Use of metal backgrounds and cabinets is strongly encouraged.
- E. The overall design, form, and structure of the EMCS shall be architecturally interesting and creative, and shall be harmonious with itself and the surrounding land uses. The design should complement the building(s) of the site for which it is emplaced, and, where appropriate, bear a strong architectural relationship to those buildings.

21.44.840 – Height, area, projection, and clearance requirements.

- A. **Height and area.** The height and area of an EMCS shall not exceed the limits set forth in Table 44-5.
- B. **Projection and clearance.**
 - 1. No portion of an electronic message center sign shall project into any right-of-way.
 - 2. The vertical clearance from grade to the lowest point of the sign is eight (8) feet for pedestrian use and fifteen (15) feet for vehicular use.

**Table 44-5
Zoning, Height, and Area Standards for Electronic Message Center Signs**

Zoning Districts		Standards		
		Permitted area (sq. ft.)	Maximum area (sq. ft.)	Maximum height (ft.)
CCA	C	Freestanding: 2/L.F. ^(a) Monument: 1/L.F. Wall: 1/L.F.	Freestanding: 150 Monument: 100 Wall: 150	Freestanding: 25 ^(c) Monument: 8 Wall: building height
CHW IL, IM, IG, IP I, P, PR	C		Freestanding: 150 ^(b) Monument: 100 Wall: 250	
Commercial and industrial character PDs ^(d)	C			

Residential and mixed-use character PDs ^(d)	N	n/a	n/a	n/a
All R zones CNP, CNA, CNR CCP, CCR, CCN	N	n/a	n/a	n/a
Abbreviations: C = Conditional use permit required, N = Not permitted, PD = Planned Development District, ft. = feet, sq. ft. = square feet, L.F. = linear feet of street frontage (or building frontage for wall-type EMCS), n/a = not applicable.				
(a) For freeway-oriented EMCS, permitted area is 3 sq. ft./L.F.				
(b) For freeway-oriented EMCS in the noted zoning districts only, maximum area is 300 sq. ft.				
(c) For freeway-oriented EMCS, maximum height is 40 ft. Where the freeway elevation is higher than the base of the sign structure, height shall be measured from the grade of the freeway lane nearest the sign (not including on- and off-ramps) to the top of the sign structure, as illustrated in Figure 44-9.				
(d) In all PDs, sign regulations specified within each PD ordinance take precedence over the provisions of this Chapter. In cases of doubt, or where the several subareas of a given PD are of differing character, the Zoning Administrator shall determine which standards should apply.				

21.44.850 – Brightness, display, copy, and message requirements. The following requirements establish the standards for the display face and copy and messages to be displayed on an electronic message center sign.

A. **Brightness.** The following brightness standards and limitations shall apply:

1. Dawn to dusk: unlimited;
2. Dusk to dawn: the display surface shall not produce luminance in excess of 0.3 foot-candles above ambient light conditions, or the level recommended by the Illuminating Engineering Society of North America (IESNA) for the specific size and location of the sign, whichever is less;
3. The display brightness shall be controlled by a photocell or light sensor that adjusts the brightness to the required dusk-to-dawn level based on ambient light conditions without the need for human input. Use of other brightness adjustment methods, such as timer- or calendar-based systems, shall only be used as a backup system;
4. The display shall be factory-certified as capable of complying with the above brightness standards. Such certification shall be provided to the satisfaction of the Director of Development Services; and
5. The sign owner shall provide to the City, upon request, certification by an independent contractor that the brightness levels of the sign are in compliance with the requirements of this Section.

B. **Display message.** The following standards and limitations shall apply to the message shown on the display surface:

1. The message shown on the EMCS display shall not flash, shimmer, glitter, or give the appearance of flashing, shimmering, or glittering.
 2. The EMCS display shall have no message or illumination which moves, or is in continuous motion, or which appears to be in continuous motion. Display of full-motion video and video-like sequences is prohibited.
 3. The display message shall not change at a rate faster than one message every eight (8) seconds.
 4. There shall be a direct change from each message to the next, with no transition effect, and no blank or dark interval in between, to avoid a flashing or blinking effect.
 5. The intensity of illumination shall not change, except as required to comply with the dusk-to-dawn brightness standards.
 6. All messages shall be limited to on site advertising of goods or services, or noncommercial messages (i.e., time, temperature, or public service announcements). All off-site advertising messages are prohibited (see “Billboard” 21.15.370); this includes messages by or for sponsors, patrons, brands, and other similar off-site parties or entities.
- C. **Fixed Copy.** Fixed/permanent sign copy on each face of an electronic message center sign shall be limited to the identification of the business, shopping or convention center name or icon and two (2) major tenants or products or services. The fixed/permanent sign copy shall not flash, shimmer, glitter, or give the appearance of flashing, shimmering, or glittering, and shall be included in the overall sign area as indicated on Table 44-5.

21.44.855 – Light and glare intrusion prevention. All electronic message center signs shall be adequately shielded and properly oriented and aimed so as to prevent the intrusion of light and glare upon residential land uses, including those in mixed-use districts.

21.44.860 – Exemptions.

- A. Electronic signs used solely to display prices for gasoline sales at gas stations shall not be required to obtain a conditional use permit. These signs shall be subject to all other applicable requirements of Chapter 21.44.
- B. Electronic message center signs and other similar electronic displays that are not visible from the public right-of-way and any other public or private property shall be exempt from the requirements of this Division, except that such a sign or display shall be adequately covered or shielded, and properly oriented and aimed, so as to prevent the emission or generation of light and glare above the sign location. All building and electrical permits shall be obtained as required by the Municipal Code.

21.44.870 – Nonconforming electronic message center signs. It is the intent of this section to recognize that the eventual elimination of existing electronic message center signs that do not conform to this Chapter is as important to Citywide aesthetic and health, safety and welfare as is the prohibition of new signs that would violate the provisions of this Chapter. It is also recognized that electronic message center signs typically require a much higher initial investment than other classes of signs, and do not recycle with the frequency of other classes of signs. Consequently, separate regulations for nonconforming EMCS are necessary to ensure that legal nonconforming EMCS are addressed as fairly as possible in a manner that avoids any unreasonable invasion of established property rights. Therefore, existing, legally-established electronic message center signs may be used and maintained as legal nonconforming signs, notwithstanding the provisions of Section 21.44.710 (Nonconforming signs), subject to the following restrictions:

- A. A nonconforming EMCS shall not be:
 - 1. Enlarged or otherwise altered to increase its display area,
 - 2. Increased in height,
 - 3. Changed to another type of nonconforming sign,
 - 4. Structurally altered to extend its useful life,
 - 5. Converted to a billboard (electronic/digital or otherwise), or
 - 6. Reestablished after damage or destruction of more than fifty percent of the value of the sign at the time of such damage or destruction.
- B. The display surface and fixed sign copy of a nonconforming EMCS may be altered and upgraded without affecting the nonconforming status of the sign, provided that such alterations comply with the requirements of Section 21.44.850 regarding brightness, display, copy, and message.
- C. Upon change of the primary land use for which the EMCS was constructed, the new owner or operator shall be required to obtain a new Conditional Use Permit in order to maintain the EMCS at the site. The Planning Commission may, at its discretion, require upgrades to the display surface, fixed copy, and other elements of the nonconforming EMCS to bring it into compliance with the requirements of Section 21.44.850. If a new Conditional Use Permit is not obtained, the EMCS shall be removed immediately.

Division IX – Signs on Public Property

21.44.900 – Signs on public property.

- A. **Applicability.** No person, except a public officer or employee performing a public duty, shall place any sign on, above, along or within any public property. This prohibition does not apply to:
1. Temporary promotional activity signs in public parks in connection with activities or uses approved by the City;
 2. Street banners, temporary holiday season decorations, and other street decorations on or suspended from lamp poles or other public structures shall be permitted when approved by the Director of Public Works and the City Manager;
 3. Signs authorized by the City inside publicly owned places of assemblage such as convention halls, auditoriums, sports arenas or stadiums which are used in a proprietary capacity;
 4. Wall signs for on-premises advertising on buildings used by concessionaires or other private commercial users or lessees of public property, when authorized by departments or agencies of the City in their proprietary capacity, and provided that any such signs comply with the provisions of Section 21.44.130 pertaining to wall or pylon signs;
 5. Painting of house numbers upon curbs in compliance with the requirements of this Code;
 6. Residential neighborhood and commercial district identification signs (see Section 21.44.240) provided:
 - a. The signs are located in parkways or in the median island of divided highways;
 - b. The signs shall comply with the established design guidelines in this Chapter; and
 - c. The applicant has a written construction and maintenance agreement approved by the Director of Public Works.
 7. Advertising, advertising displays or donor recognition permitted pursuant to Chapter 16.55
- B. **Permit Required.** Any person who intends to place a private sign on public property as permitted by Subsection 21.44.090.A shall first obtain a permit from either the Director of Public Works or in the case of public property used in a proprietary capacity, from the department or agency of the City in charge of such property. A permit application form shall be provided by the City. The City Council, by resolution, may establish permit fees and may authorize

rental rates or other appropriate charges for this permitted use of public property.

C. In the Coastal Zone:

1. On the sandy beach, the placement of private freestanding signs is prohibited.
2. Prior to the placement of any private sign on public property located adjacent to the sandy beach, a coastal development permit shall be approved for a comprehensive sign plan. A comprehensive sign plan shall include specific standards for the size, number and location of proposed signs. A coastal development permit for a comprehensive sign plan shall be approved only if a positive finding is made that the sign or signs included in the plan do not:
 - a. Obstruct public views to or along the coast;
 - b. Adversely impact public access to and use of the water;
 - c. Adversely impact public recreational use of a public park or beach; or
 - d. Otherwise adversely affect recreation, access or the visual resources of the coast.
3. A coastal development permit shall be required for any sign placed on public property in the Coastal Zone, except that a coastal development permit shall not be required for: wall signs; signs on the interior of structures; signs comprised solely of paint on existing structures; temporary banners, and flags displayed for a period not to exceed ninety (90) days; warning signs; traffic safety signs; and public service signs less than four (4) square feet that identify public conveniences (e.g., restrooms, telephones, hours of operation, government ordinances). A coastal development permit for a sign on public property shall be approved only if a positive finding is made that the sign design and scale does not:
 - a. Obstruct views to or along the coast from publicly accessible places;
 - b. Adversely impact public access to and use of the water;
 - c. Adversely impact public recreational use of a public park or beach; or
 - d. Otherwise adversely affect recreation, access or the visual resources of the coast.

- D. Removal of Signs.** Any sign permitted on public property shall be removed by the party responsible for its posting immediately after the conclusion of the advertised event or by the removal date established by ordinance, regulation,

contract or event. If such sign is not removed by that time, it shall be deemed abandoned and may be summarily removed by the City. The person or entity responsible for posting said sign shall be liable for the City's costs incurred in the removal of such sign, and the City Manager or his/her designee is authorized to collect said costs.

- E. **Illegal Signs.** Any sign placed on public property in violation of the provisions of this Section is declared a public nuisance and may be summarily removed by the City. The person or entity responsible for such illegal posting shall be liable for the City's costs incurred in the removal of such sign, and the City Manager or his/her designee is authorized to collect said costs.

ORDINANCE NO.

AN ORDINANCE OF THE CITY COUNCIL OF THE
 CITY OF LONG BEACH AMENDING THE LONG BEACH
 MUNICIPAL CODE BY AMENDING SECTIONS 21.15.2510,
 21.15.2520, 21.15.2550, 21.15.2570, 21.15.2571,
 21.15.2573, 21.15.2577, 21.15.2580, 21.15.2600,
 21.15.2620, 21.15.2630, 21.15.2700, 21.15.2710,
 21.15.2720, 21.15.2730, 21.15.2740, 21.15.2750,
 21.15.2980, BY AMENDING AND RESTATING IN ITS
 ENTIRETY CHAPTER 21.44, AND BY AMENDING
 SECTION 21.52.229; BY ADDING SECTIONS 21.15.2570.5,
 21.15.2575, 21.15.2595, 21.15.2665, 21.15.2721,
 21.15.2723, 21.15.2743, 21.15.2745, AND 21.15.2755; AND
 BY REPEALING SECTIONS 21.15.2540, 21.15.2560,
 21.15.2640, 21.15.2670, 21.15.2680, 21.15.2690, AND
 21.15.2725, ALL RELATING TO SIGNS

Section 1. Section 21.15.2510 of the Long Beach Municipal Code is amended to read as follows:

21.15.2510 Sign.

"Sign" means any device or structure used for visual communication or attraction, including any announcement, declaration, demonstration, display, illustration, insignia, model, statue, or symbol used to identify a place, or to advertise or promote the interest of any person; together with a framework, ~~background material structure, component parts, and bracing materials (not including the supporting pole on freestanding signs)~~ all appurtenant components, backgrounds, and

OFFICE OF THE CITY ATTORNEY
 CHARLIE PARKIN, City Attorney
 333 West Ocean Boulevard, 11th Floor
 Long Beach, CA 90802-4664

1 supporting structures, except the building upon which a sign is placed.
2 Official traffic-control devices are specifically exempted from this definition.
3 The official flags of nations, states, counties, cities and recognized
4 nonprofit organizations shall not be considered signs, but flags, banners or
5 similar devices containing a commercial message shall be signs.
6

7 Section 2. Section 21.15.2520 of the Long Beach Municipal Code is
8 amended to read as follows:

9 21.15.2520 Sign, abandoned.

10 "Abandoned sign" means the sign face, frame and supporting pole
11 or structure, and all appurtenances, of any permanent sign advertising for a
12 business, institution, or other land use which has abandoned the premises
13 for ninety (90) days or more, or any land use for which the business license
14 has expired and remained expired for one year. Abandoned sign also
15 includes any promotional activity sign advertising ~~an activity which ended~~
16 ~~five (5) or more days previous~~ for which the permit has expired. Signs
17 associated with a demolished or abandoned building shall also be
18 considered abandoned signs. See also "Abandoned" (Section 21.15.030).
19

20 Section 3. Section 21.15.2550 of the Long Beach Municipal Code is
21 amended to read as follows:

22 21.15.2550 Sign, awning.

23 "Awning sign" means a sign that is applied, painted or affixed to an
24 awning.
25

26 Section 4. Section 21.15.2570 of the Long Beach Municipal Code is
27 amended to read as follows:

28 21.15.2570 Sign, banner.

1 See "Sign, promotional activity – Commercial. (Section
2 21.15.2720)."

3 ~~"Banner sign" means a promotional activity sign with wording or symbols.~~
4

5 Section 5. Section 21.15.2571 of the Long Beach Municipal Code is
6 amended to read as follows:

7 21.15.2571 Sign, changeable copy.

8 A sign whose copy is periodically changed to advertise events,
9 sales, and the like, with detachable but motionless lettering that must be
10 manually installed, usually on a series of parallel tracks. A changeable
11 copy sign shall not include a "trivision" sign, electronic sign, or electronic
12 message center sign, or time, date, and temperature sign.
13

14 Section 6. Section 21.15.2573 of the Long Beach Municipal Code is
15 amended to read as follows:

16 21.15.2573 Sign, community residential neighborhood or commercial district
17 identification.

18 _____A "residential neighborhood identification sign" or "commercial
19 district identification sign" identifies a residential neighborhood and/or
20 commercial or industrial district(s), and may announce its geographical
21 boundaries (i.e., now entering or leaving neighborhood or district name)
22 within the City. This sign shall always identify that the respective
23 neighborhood or district is part of the City.

24 ~~A "community identification sign" identifies a community comprised of
25 various residential neighborhoods and/or commercial or industrial
26 district(s) and announces its geographical boundaries (i.e., now entering
27 or leaving community name) within the City. This sign shall always identify
28 that the respective community is part of the City.~~

1 Section 7. Section 21.15.2577 of the Long Beach Municipal Code is
2 amended to read as follows:

3 21.15.2577 Sign, electronic message center.

4 "Electronic message center sign" is a sign whose alphabetic,
5 pictographic, or symbolic informational content can be changed or altered
6 on a fixed display surface composed of electronically electrically-
7 illuminated or mechanically driven changeable segments. This includes
8 signs that have to be preprogrammed to display only certain types of
9 information (i.e., time, date, temperature) and signs whose informational
10 content can be changed or altered by means of computer- or circuit-driven
11 electronic impulses. An electronic message center sign displays only on-
12 site sign copy, information, and advertising; otherwise it shall be
13 considered a billboard. Electronic message center sign does not include a
14 sign that displays only time, date, and/or temperature if it is six (6) square
15 feet or smaller.

OFFICE OF THE CITY ATTORNEY
CHARLIE PARKIN, City Attorney
333 West Ocean Boulevard, 11th Floor
Long Beach, CA 90802-4664

1
2
3
4
5
6
7
8
9
10
11
12
13
14
15
16
17
18
19
20
21
22
23
24
25
26
27
28

1
2
3
4
5
6
7
8
9
10
11
12
13
14
15
16
17
18
19
20
21
22
23
24
25
26
27
28

Section 8. Section 21.15.2580 of the Long Beach Municipal Code is amended to read as follows:

21.15.2580 Sign, freestanding.

———"Freestanding sign" means a sign which is supported by a structure connected permanently to the ground, or displayed directly upon a base connected permanently to the ground, and which is not structurally connected to a building or other structure. This includes but is not limited to those signs known as "pole signs." See also "Monument sign" (Section 21.15.2620). ~~"Freestanding sign" means a sign which is displayed directly on the ground on a base as wide as the sign and which is supported neither wholly nor in part by a building.~~

Section 9. Section 21.15.2600 of the Long Beach Municipal Code is amended to read as follows:

21.15.2600 Sign, marquee/canopy.

"Marquee/canopy sign" means a sign that is attached to the vertical face or the soffit of a marquee or canopy. See "Awning sign." (Section 21.15.2550).

Section 10. Section 21.15.2620 of the Long Beach Municipal Code is amended to read as follows:

OFFICE OF THE CITY ATTORNEY
CHARLIES PARKIN, City Attorney
333 West Ocean Boulevard, 11th Floor
Long Beach, CA 90802-4664

OFFICE OF THE CITY ATTORNEY
CHARLIE PARKIN, City Attorney
333 West Ocean Boulevard, 11th Floor
Long Beach, CA 90802-4664

1
2
3
4
5
6
7
8
9
10
11
12
13
14
15
16
17
18
19
20
21
22
23
24
25
26
27
28

21.15.2620 Sign, monument.

"Monument sign" means a sign that is displayed directly on the ground, ~~or on a base which is the same width as the sign.~~ on a base connected permanently to the ground, and which is not structurally connected to a building or structure. See also "Freestanding sign" (Section 21.15.2580).

Section 11. Section 21.15.2630 of the Long Beach Municipal Code is amended to read as follows:

21.15.2630 Sign, neighborhood marker.

"Neighborhood marker sign" means a small sign placed above the ~~street signs in neighborhoods with clearly local identities within the City of Long Beach to identify the unofficial/common name of the neighborhood~~ upon a street light standard or traffic signal pole to identify a residential neighborhood or commercial district. These signs are administered by the Department of Public Works, and not regulated in Title 21 (see Section 21.44.240)

Section 12. Section 21.15.2700 of the Long Beach Municipal Code is amended to read as follows:

21.15.2700 Sign, portable.

"Portable sign" means a freestanding sign standing upon the ground but not permanently located upon a foundation. This includes, but is not limited to, those signs known as "sandwich-board signs," "A-frame signs," and "sidewalk signs."

Section 13. Section 21.15.2710 of the Long Beach Municipal Code is amended to read as follows:

OFFICE OF THE CITY ATTORNEY
CHARLIE PARKIN, City Attorney
333 West Ocean Boulevard, 11th Floor
Long Beach, CA 90802-4664

1
2
3
4
5
6
7
8
9
10
11
12
13
14
15
16
17
18
19
20
21
22
23
24
25
26
27
28

21.15.2710 Sign, projecting.

"Projecting sign" means a sign which is attached to, and projects outward at an angle from, a wall or other essentially vertical plane of a building or structure. A projecting sign also may be known as a "blade sign."

Section 14. Section 21.15.2720 of the Long Beach Municipal Code is amended to read as follows:

21.15.2720 Sign, promotional activity - Commercial.

"Promotional activity sign-Commercial" means any sign made of cloth or paper taking the form of a banner, balloon, kite, placard, pennant or similar device, or painted on a window area utilized to promote or advertise a commercial activity or event that is permitted on a temporary basis under the provisions of Section 21.44.410, for the purpose of announcing an event, product, service, or sale of a temporary nature. Promotional activity signs are made of non-permanent materials such as cloth, vinyl, or mesh, and are not permanently attached or affixed to a building. Promotional activity signs commonly are known as "banners."

Section 15. Section 21.15.2730 of the Long Beach Municipal Code is amended to read as follows:

21.15.2730 Sign, roof.

"Roof sign" means a sign that is mounted or positioned on the roof of a building or which is wholly dependent upon a building for support and which projects above the point parapet wall of a building with a flat roof, or above the eave line of a building with a sloped roof (gambrel, gable or hip roof), or above the deck line of a building with a mansard roof.

1 Section 16. Section 21.15.2740 of the Long Beach Municipal
2 Code is amended to read as follows:

3 21.15.2740 Sign, temporary.

4 "Temporary sign" means ~~any sign of cloth, paper or similar material~~
5 ~~(except as window signs). These are considered promotional activity~~
6 ~~signs.~~ refers to those signs that are permitted on a temporary basis in
7 Division IV of Chapter 21.44. See also "Promotional activity sign-
8 Commercial." (Section 21.15.2720).

9
10 Section 17. Section 21.15.2750 of the Long Beach Municipal
11 Code is amended to read as follows:

12 21.15.2750 Sign, wall.

13 "Wall sign" means a sign fastened to ~~or painted on the wall of a~~
14 building or structure in such a manner that the wall becomes the
15 supporting structure for or forms the background surface of the sign. Such
16 a sign may not project more than fourteen inches (14") beyond the vertical
17 wall surface or it shall be considered a projecting sign.

18
19 Section 18. Section 21.15.2980 of the Long Beach Municipal
20 Code is amended to read as follows:

21 21.15.2980 Supergraphics.

22 "Supergraphic" means a sign, containing either on-site or off-site
23 advertising, consisting of sign copy and/or an image that is applied to and
24 ~~made integral with~~ a building, structure, or wall, or projected onto a
25 building, structure, or wall, or printed on vinyl, mesh, fabric, or any other
26 material, and hung from or wrapped about a building or structure, and
27 which does not comply with the provisions of Sections 21.44.070 (Exempt
28 Signs), 21.44.130 (Wall Signs), 21.44.220 (Backdrop Wall Signs),

OFFICE OF THE CITY ATTORNEY
CHARLES PARKIN, City Attorney
333 West Ocean Boulevard, 11th Floor
Long Beach, CA 90802-4664

1 ~~21.44.310 (Promotional Activity Signs), or Chapter 21.54 (Billboards).~~
2 requirements for a permitted sign type under the provisions of Chapter
3 21.44, or the requirements for a billboard under Chapter 21.54. The term
4 "supergraphic" also shall include signs known as "building wraps."

5
6 Section 19. Chapter 21.44 of the Long Beach Municipal Code is
7 amended and restated in its entirety to read as shown on Attachment "A."

8
9 Section 20. Section 21.52.229 of the Long Beach Municipal Code
10 is amended to read as follows:

11 21.52.229 Electronic message center signs.

12 In addition to the required findings for a conditional use permit
13 (Section 21.25.206), the Planning Commission shall not approve a
14 conditional use permit for an Electronic Message Center sign unless
15 positive findings can be made for the following:

16 A. The proposed design of the electronic message center sign
17 is complete and consistent within itself and is compatible in design with
18 the architectural theme or character of the existing or proposed
19 development it will serve and the community in which it will be located.

20 B. The establishment of the proposed electronic message
21 center sign will not adversely affect the character, livability, or quality of life
22 of any residential community it will be adjacent to or located in.

23 C. The electronic message center sign shall not constitute a
24 hazard to the safe and efficient operation of vehicles upon a street or
25 freeway.
26
27
28

OFFICE OF THE CITY ATTORNEY
CHARLIE PARKIN, City Attorney
333 West Ocean Boulevard, 11th Floor
Long Beach, CA 90802-4664

OFFICE OF THE CITY ATTORNEY
CHARLIE PARKIN, City Attorney
333 West Ocean Boulevard, 11th Floor
Long Beach, CA 90802-4664

1
2
3
4
5
6
7
8
9
10
11
12
13
14
15
16
17
18
19
20
21
22
23
24
25
26
27
28

D. The applicant has demonstrated that the proposed electronic message display surface is factory-certified as capable of complying with the brightness standards in Section 21.44.850.

~~A. In addition to the required findings for a conditional use permit (section 21.25.206), positive findings shall also be made for the following:~~

- ~~1. The proposed design of the electronic message center sign is complete and consistent within itself and is compatible in design with the architectural theme or character of the existing or proposed development it will serve and the community in which it will be located.~~
- ~~2. The establishment of the proposed electronic message center sign will not adversely affect the character, livability, or quality of life of the residential community it will be adjacent to or located in.~~

~~B. No permit shall be issued for an electronic message center sign which constitutes a hazard to the safe and efficient operation of vehicles upon a street or freeway.~~

~~Thus, the following conditions shall apply to all electronic message center signs:~~

- ~~1. The electronic message center display shall have no illumination which is in continuous motion or which appears to be in continuous motion.~~
- ~~2. The display message will not change at a rate faster than one message every four (4) seconds.~~
- ~~3. The interval between messages will not be less than one second.~~
- ~~4. The intensity of illumination will not change.~~
- ~~5. All messages shall be limited to on site advertising of goods or services or noncommercial messages (i.e., time and temperature).~~
- ~~6. All electric signs shall conform to the electrical code of the city.~~

Section 21. Section 21.15.2570.5 is added to the Long Beach Municipal Code to read as follows:

OFFICE OF THE CITY ATTORNEY
CHARLIE PARKIN, City Attorney
333 West Ocean Boulevard, 11th Floor
Long Beach, CA 90802-4664

1
2
3
4
5
6
7
8
9
10
11
12
13
14
15
16
17
18
19
20
21
22
23
24
25
26
27
28

21.15.2570.5 Sign, building identification.

“Building identification sign” means a sign which serves to identify only the name, address, and use or principal tenant of the premises upon which it is located and provides no other advertisements or product identification.

Section 22. Section 21.15.2575 is added to the Long Beach Municipal Code to read as follows:

21.15.2575 Sign, cabinet.

“Cabinet sign” means sign with one or several faces, which contains all the text and/or logo symbols of each face upon a facing made of translucent and/or opaque material contained within a single enclosed cabinet, box or can. A cabinet sign may or may not be internally illuminated.

Section 23. Section 21.15.2595 is added to the Long Beach Municipal Code to read as follows:

21.15.2595 Sign, interior.

“Interior sign” means a sign that is located between one (1) and six (6) feet to the interior of any window through which the sign is visible.

Section 24. Section 21.15.2665 is added to the Long Beach Municipal Code to read as follows:

21.15.2665 Sign, on-site directional.

“On-site directional sign” means a class of sign that directs persons to a destination within the subject site, typically a parking lot. An on-site directional sign contains simple information such as “Enter,” “Exit,” “This Way,” or “Do Not Enter,” as well as a business name and/or logo. An on-

OFFICE OF THE CITY ATTORNEY
CHARLIE PARKIN, City Attorney
333 West Ocean Boulevard, 11th Floor
Long Beach, CA 90802-4664

1 site directional sign is intended for traffic internal to the site, and is not
2 directed at traffic on an adjacent road or right-of-way.

3
4 Section 25. Section 21.15.2721 is added to the Long Beach Municipal
5 Code to read as follows:

6 21.15.2721 Sign, promotional activity – Non-commercial
7 “Promotional activity sign – Non-commercial” means any sign made
8 of cloth or paper taking the form of a banner, placard, sign board, or
9 similar device or structure and which is utilized to promote, advertise, or
10 advocate for or against a particular person, event or activity in a non-
11 commercial context. Non-commercial promotional activity signs shall be
12 removed from a premise no later than five (5) days following the
13 conclusion of the activity or event promoted by such sign.

14
15 Section 26. Section 21.15.2723 is added to the Long Beach Municipal
16 Code to read as follows:

17 21.15.2723 Sign, push-through.
18 “Push-through sign” or “push-through cabinet sign” refers to a
19 cabinet sign with sign copy rendered in relief either in front of or behind
20 the sign face, similar to channel letters. A push-through sign typically is
21 internally illuminated with an opaque face, creating a halo effect, although
22 other designs such as illuminated letters or exposed neon in open-faced
23 letters are acceptable as well.

24
25 Section 27. Section 21.15.2743 is added to the Long Beach Municipal
26 Code to read as follows:

27 21.15.2743 Sign, through-the-face.
28 See “Sign, push-through” (Section 21.15.2723).

1
2
3
4
5
6
7
8
9
10
11
12
13
14
15
16
17
18
19
20
21
22
23
24
25
26
27
28

Section 28. Section 21.15.2745 is added to the Long Beach Municipal Code to read as follows:

21.15.2745 Sign, traffic directional.

“Traffic directional sign” means any sign displayed to ensure the safe and orderly flow of automobile traffic on private property. These consist of stop signs, one-way signs, do not enter signs, speed limit signs, left/right turn-only signs, no left/right turn signs, and other traffic signs of like purpose. Traffic directional signs do not contain business information or directions to a destination. Traffic directional signs shall conform to official traffic control device standards as directed by the City Traffic Engineer.

Section 29. Section 21.15.2755 is added to the Long Beach Municipal Code to read as follows:

21.15.2755 Sign, wall painted.

_____ “Wall-painted sign” means a sign that is painted on a building wall in lieu of a permanent, fixed wall sign structure.

Section 30. Sections 21.15.2540, 21.15.2560, 21.15.2640, 21.15.2670, 21.15.2680, 21.15.2690, and 21.15.2725 of the Long Beach Municipal Code are hereby repealed.

Section 31. The City Clerk shall certify to the passage of this ordinance by the City Council and cause it to be posted in three conspicuous places in the City of Long Beach, and it shall take effect on the thirty-first day after it is approved by the Mayor.

//
//

OFFICE OF THE CITY ATTORNEY
CHARLES PARKIN, City Attorney
333 West Ocean Boulevard, 11th Floor
Long Beach, CA 90802-4664

1
2
3
4
5
6
7
8
9
10
11
12
13
14
15
16
17
18
19
20
21
22
23
24
25
26
27
28

I hereby certify that the foregoing ordinance was adopted by the City Council of the City of Long Beach at its meeting of _____, 2013, by the following vote:

Ayes: Councilmembers: _____

Noes: Councilmembers: _____

Absent: Councilmembers: _____

City Clerk

Approved: _____

Mayor

OFFICE OF THE CITY ATTORNEY
CHARLIES PARKIN, City Attorney
333 West Ocean Boulevard, 11th Floor
Long Beach, CA 90802-4664

H-1
ATTACHMENT

RESOLUTION NO.

A RESOLUTION OF THE CITY COUNCIL OF THE
CITY OF LONG BEACH AUTHORIZING THE DIRECTOR OF
DEVELOPMENT SERVICES TO SUBMIT AMENDMENTS
TO THE LONG BEACH ZONING REGULATIONS TO THE
CALIFORNIA COASTAL COMMISSION FOR APPROVAL

WHEREAS, on August 13, 2013, the City Council of the City of Long Beach
amended certain provisions of the Long Beach Zoning Regulations, Title 21 of the Long
Beach Municipal Code, relating to the regulation of on-premises signs, amendments
related to sign definitions and conditional use findings for signs; and

WHEREAS, it is the desire of the City Council to submit the above
referenced zoning regulation amendments to the California Coastal Commission for its
review; and

WHEREAS, the Planning Commission and City Council gave full
consideration to all facts and the proposals respecting the amendments to the zoning
regulations at a properly noticed and advertised public hearing; and

WHEREAS, the City Council approved the proposed amendments to the
zoning regulations by adopting amendments to Chapter 21.44, as well as amendments to
sign definitions in Chapter 21.15, and amendments to conditional use findings for signs in
Chapter 21.52. The proposed zoning regulation amendments are to be carried out in a
manner fully consistent with the Coastal Act and become effective in the Coastal Zone
immediately upon Coastal Commission certification; and

WHEREAS, the City Council hereby finds that the proposed amendments
will not adversely affect the character, livability or appropriate development in the City of
Long Beach and that the amendments are consistent with the goals, objectives and
provisions of the General Plan.

OFFICE OF THE CITY ATTORNEY
CHARLES PARKIN, City Attorney
333 West Ocean Boulevard, 11th Floor
Long Beach, CA 90802-4664

1
2
3
4
5
6
7
8
9
10
11
12
13
14
15
16
17
18
19
20
21
22
23
24
25
26
27
28

NOW, THEREFORE, the City Council of the City of Long Beach resolves as follows:

Section 1. The amendment to the Long Beach Zoning Regulations of the City of Long Beach adopted on August 13, 2013, by Ordinance No. ORD-13-_____, a copy of which is attached to and incorporated in this resolution as Exhibit "A", is hereby submitted to the California Coastal Commission for its earliest review as to that part of the ordinance that directly affects land use matters in that portion of the California Coastal Zone within the City of Long Beach.

Section 2. The Director of Development Services of the City of Long Beach is hereby authorized to and shall submit a certified copy of this resolution, together with appropriate supporting materials, to the California Coastal Commission with a request for its earliest action, as an amendment to the Local Coastal program that will take effect automatically upon Commission approval pursuant to the Public Resources Code or as an amendment that will require formal City Council adoption after Coastal Commission approval.

Section 3. This resolution shall take effect immediately upon its adoption by the City Council, and the City Clerk shall certify the vote adopting this resolution.

I certify that this resolution was adopted by the City Council of the City of Long Beach at its meeting of _____, 2013, by the following vote:

Ayes: Councilmembers: _____

Noes: Councilmembers: _____

Absent: Councilmembers: _____

City Clerk