



Robert E. Shannon  
City Attorney of Long Beach  
333 West Ocean Boulevard  
Long Beach, California 90802-4664  
Telephone (562) 570-2200

1 date this agreement is last executed. Assignee understands that it must immediately  
2 furnish insurance and contact information to City, and failure to do so within 10 days of this  
3 assignment shall be considered a breach of the Contract.

4 Assignee agrees to indemnify, defend and hold Assignor harmless from any and all  
5 liabilities, claims, causes of action, or expenses with respect to the Contract to the extent  
6 relating to or caused by acts, events, omissions, or conditions occurring from and after the  
7 date of this assignment.

8 Both Assignor and Assignee agree to indemnify, defend, and hold the City of Long  
9 Beach harmless from any liabilities, claims, causes of action, or expenses which are  
10 related to the assignment of this contract. Both Assignor and Assignee agree to implement  
11 the assignment in a manner which does not negatively affect the present schedule and  
12 plan for the installation of catch basin inserts.

13 This agreement shall be subject to and interpreted under the laws of the State of  
14 California.

15 The parties have executed this agreement as of the date first provided above.

16 CITY OF LONG BEACH, a municipal  
17 corporation

18 2-7, 2006

19 By [Signature]  
20 City Manager  
"City"

21 ASBURY ENVIRONMENTAL SERVICES  
22 a California corporation

23 1-19, 2006

24 By [Signature]  
25 Title: President

"Assignor"

26 AbTech Industries, Inc.

27 1-31, 2006

28 By [Signature]  
Title: PRESIDENT

"Assignee"

**CALIFORNIA ALL-PURPOSE ACKNOWLEDGMENT**

State of Arizona  
~~California~~

County of Maricopa

} ss.

On 1-31-06, before me, Lane J. Castleton, Notary Public,  
Date Name and Title of Officer (e.g., "Jane Doe, Notary Public")

personally appeared Glenn R. Rink,  
Name(s) of Signer(s)

personally known to me

proved to me on the basis of satisfactory evidence to be the person(s) whose name(s) is/are subscribed to the within instrument and acknowledged to me that he/she/they executed the same in his/her/their authorized capacity(ies), and that by his/her/their signature(s) on the instrument the person(s), or the entity upon behalf of which the person(s) acted, executed the instrument.

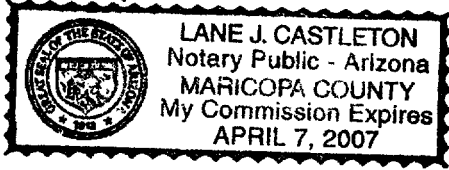

WITNESS my hand and official seal.

Place Notary Seal Above

Lane J. Castleton  
Signature of Notary Public

**OPTIONAL**

Though the information below is not required by law, it may prove valuable to persons relying on the document and could prevent fraudulent removal and reattachment of this form to another document.

**Description of Attached Document**

Title or Type of Document: Assignment of Contract Rights and Obligations and Consent to Assignment

Document Date: 1-19-06 Number of Pages: 3

Signer(s) Other Than Named Above: \_\_\_\_\_

**Capacity(ies) Claimed by Signer(s)**

Signer's Name: Glenn R. Rink

- Individual
- Corporate Officer — Title(s): President/CEO
- Partner —  Limited  General
- Attorney in Fact
- Trustee
- Guardian or Conservator
- Other: \_\_\_\_\_

RIGHT THUMBPRINT OF SIGNER  
Top of thumb here

Signer Is Representing: AbTech Industries, Inc.

Signer's Name: \_\_\_\_\_

- Individual
- Corporate Officer — Title(s): \_\_\_\_\_
- Partner —  Limited  General
- Attorney in Fact
- Trustee
- Guardian or Conservator
- Other: \_\_\_\_\_

RIGHT THUMBPRINT OF SIGNER  
Top of thumb here

Signer Is Representing: \_\_\_\_\_

# CALIFORNIA ALL-PURPOSE ACKNOWLEDGMENT

State of California

County of Los Angeles

} ss.

On January 19, 2006, before me, Jessica Torres Cortes, Notary Public,  
Date Name and Title of Officer (e.g., "Jane Doe, Notary Public")

personally appeared Steve Kerdoon  
Name(s) of Signer(s)



personally known to me

proved to me on the basis of satisfactory evidence to be the person~~(s)~~ whose name~~(s)~~ is/~~are~~ subscribed to the within instrument and acknowledged to me that he/~~she~~/they executed the same in his/~~her~~/their authorized capacity~~(ies)~~, and that by his/~~her~~/their signature~~(s)~~ on the instrument the person~~(s)~~, or the entity upon behalf of which the person~~(s)~~ acted, executed the instrument.

Place Notary Seal Above

WITNESS my hand and official seal

*Jessica Torres Cortes*  
Signature of Notary Public

## OPTIONAL

Though the information below is not required by law, it may prove valuable to persons relying on the document and could prevent fraudulent removal and reattachment of this form to another document.

### Description of Attached Document

Title or Type of Document: Assignment of Contract Rights & Obligations & Consent to Assignment

Document Date: January 19th, 2006 Number of Pages: Three

Signer(s) Other Than Named Above: N/A

### Capacity(ies) Claimed by Signer(s)

Signer's Name: Steve Kerdoon

- Individual  
 Corporate Officer — Title(s): President  
 Partner —  Limited  General  
 Attorney in Fact  
 Trustee  
 Guardian or Conservator  
 Other: \_\_\_\_\_

RIGHT THUMBPRINT  
OF SIGNER  
Top of thumb here

Signer Is Representing: \_\_\_\_\_  
Asbury Environmental Svcs

Signer's Name: \_\_\_\_\_

- Individual  
 Corporate Officer — Title(s): \_\_\_\_\_  
 Partner —  Limited  General  
 Attorney in Fact  
 Trustee  
 Guardian or Conservator  
 Other: \_\_\_\_\_

RIGHT THUMBPRINT  
OF SIGNER  
Top of thumb here

Signer Is Representing: \_\_\_\_\_

1  
2  
3  
4  
5  
6  
7  
8  
9  
10  
11  
12  
13  
14  
15  
16  
17  
18  
19  
20  
21  
22  
23  
24  
25  
26  
27  
28

The foregoing Agreement is hereby approved as to form this

3<sup>rd</sup> day of February, 2006.

ROBERT E. SHANNON, City Attorney

By  Deputy

Robert E. Shannon  
City Attorney of Long Beach  
333 West Ocean Boulevard  
Long Beach, California 90802-4664  
Telephone (562) 570-2200

LPM:et:fi  
01/12/06  
05-02822  
L:\APPS\CtyLaw32\WPDOCS\ID012\IP005\00084303.WPD

**ORIGINAL**

AGREEMENT

1  
2  
3  
4  
5  
6  
7  
8  
9  
10  
11  
12  
13  
14  
15  
16  
17  
18  
19  
20  
21  
22  
23  
24  
25  
26  
27  
28

Robert E. Shannon  
City Attorney of Long Beach  
333 West Ocean Boulevard  
Long Beach, California 90802-4664  
Telephone (562) 570-2200

THIS AGREEMENT is made and entered, in duplicate, as of June 23, 2004 for reference purposes only, pursuant to a minute order of the City Council at its meeting held on May 4, 2004, by and between ASBURY ENVIRONMENTAL SERVICES, a California corporation, ("Contractor") with its principal place of business at 2100 N. Alameda, Compton, California 90222, and THE CITY OF LONG BEACH, a municipal corporation ("City.")

WHEREAS, pursuant to minute order the City Council authorized the City Manager to enter a contract with Contractor for furnishing, installing and monitoring Smart Sponge and Ultra Urban Filter Technology catch basin inserts ("the Work"),

NOW, THEREFORE, in consideration of the mutual terms and conditions herein contained, the parties agree as follows:

1. Scope of Work.

A. Purchase and Installation. Contractor shall sell to the City and install as requested, and at the locations directed by, the City Engineer, Smart Sponge and Ultra Urban Filter Technology catch basin inserts ("the Units"). Such Units are described in a letter from Contractor dated April 2, 2004 and shown on five pages of drawings, all attached hereto as Exhibit "A." The installation of the Units is a Public Work and Contractor agrees to comply with all of the laws and regulations pertaining thereto, including but not limited to prevailing wage rates.

B. Monitoring and Data Collection. Contractor shall also: (a) provide monitoring at such times and locations as directed by the City Engineer ("Monitoring Event" or "Monitoring Events"), to the standards set forth on Exhibit "B" and (b) document data collection in a format approved by the City Engineer.

C. Maintenance. Contractor shall maintain the Units in good working condition without additional cost to City during the life of the contract. This obligation is

1 separate from the warranty provisions of Section 3, below.

2 D. Contractor acknowledges and agrees that no subcontractors will perform  
3 installation or maintenance of the units but that the units will be installed and maintained  
4 by Contractor's employees.

5 2. Payment. City shall pay to Contractor the sum of four hundred and fifty  
6 dollars (\$455.00) per Unit, which includes tax, installation and all tasks identified in Section  
7 1 above, not to exceed one million dollars. (\$1,000,000) including applicable taxes. The  
8 foregoing price does not include federal excise tax from which municipalities are exempt,  
9 and none shall be charged to the City. Payment for the purchase and installation of the  
10 Units shall be made in due course of payments of the City after installation and receipt of  
11 invoices from Contractor. Invoices for monitoring may be submitted monthly or at less  
12 frequent intervals as the Contractor chooses, so long as the invoice for each event of  
13 monitoring is submitted within forty-five days of date of the monitoring event.

14 3. Warranty. Contractor guarantees for a period of six (6) months beginning  
15 on the date of installation of each unit that such unit is and shall be free from defects, and  
16 Contractor shall replace or repair it to the satisfaction of the City Engineer. Any repair or  
17 parts replaced during the guarantee period shall have the benefit of a full one (1) year  
18 warranty starting on the date of completion of the repair or replacement.

19 4. The term of this Agreement shall begin on the date it is fully executed and  
20 shall end at midnight on September 30, 2005.

21 5. Termination. This agreement may be terminated by City by giving notice  
22 to Contractor in the manner described below. Termination or expiration of this Agreement  
23 shall not terminate rights or liabilities which accrued or existed prior to termination or  
24 expiration.

25 6. Assignment. No portion of this Agreement nor any of the monies which  
26 may become due to Contractor hereunder may be assigned by Contractor without the prior  
27 written consent of the City.

28 7. Waiver. The acceptance of any item by the City or the payment of any

1 money by the City shall not operate as a waiver of any provision of this Agreement, or of  
2 any power of the City, or of any right to damages. The waiver of any breach or default  
3 hereunder shall not be held to be a waiver of any other or subsequent breach or default.

4 8. Audit. Because payment of a part of the consideration for this Agreement  
5 is made with State funds, the City and the State of California shall have the right at all  
6 reasonable times to examine, audit, inspect, review, extract information from, and copy all  
7 books, records, accounts, and other information relating to this Agreement.

8 9. Insurance. As a condition precedent to the effectiveness of this  
9 Agreement, Contractor shall obtain and maintain at its cost for the duration of this  
10 Agreement from insurance companies that are admitted to write insurance in California or  
11 from authorized non-admitted insurance companies that have ratings of or equivalent to  
12 A:VIII by A.M. Best Company:

13 (a) Commercial general liability insurance (equivalent  
14 in scope to ISO form CG 00 01 11 85 or CG 00 01 11 88) in an  
15 amount not less than One Million Dollars (\$1,000,000) per  
16 occurrence and Two Million Dollars (\$2,000,000) general  
17 aggregate. Such coverage shall include but not be limited to  
18 broad form contractual liability, cross liability, independent  
19 contractors liability, and products and completed operations  
20 liability. The City, its officials, employees and agents shall be  
21 named as additional insureds by endorsement (on the City's  
22 endorsement form or on an endorsement equivalent in scope  
23 to ISO form CG 20 10 11 85 or CG 20 26 11 85), and this  
24 insurance shall contain no special limitations on the scope of  
25 protection given to the City, its officials, employees and agents

26 (b) Workers' compensation insurance as required by  
27 the California Labor Code and employer's liability insurance  
28 in an amount not less than One Million Dollars (\$1,000,000)



1 per accident.

2 (c) Commercial automobile liability insurance  
3 (equivalent in scope to ISO form CA 00 01 06 92), covering  
4 Auto Symbol 1 (Any Auto), in an amount not less than Five  
5 Hundred Thousand Dollars (\$500,000) combined single limit  
6 per accident.

7 Any self-insurance program, self-insured retention, or deductible must be  
8 separately approved in writing by City's Risk Manager or designee and shall protect the  
9 City, its officials, employees and agents in the same manner and to the same extent as  
10 they would have been protected had the policy or policies not contained retention or  
11 deductible provisions. Each insurance policy shall be endorsed to state that coverage shall  
12 not be reduced in coverage, nonrenewed, or canceled except after thirty (30) days prior  
13 written notice to City, and shall be primary and not contributing to any other insurance or  
14 self-insurance maintained by the City, the City, and their officials, employees and agents.  
15 Contractor shall notify the City within five (5) days after any insurance required herein has  
16 been voided by the insurer or cancelled by the insured. If this coverage is written on a  
17 "claims-made" basis, it must provide for an extended reporting period of not less than one  
18 year, commencing on the date this Agreement expires or is terminated, unless Contractor  
19 guarantees that Contractor will provide to the City evidence of uninterrupted, continuing  
20 coverage for a period of not less than three years, commencing on the date this Agreement  
21 expires or is terminated.

22 Contractor shall require that all subcontractors, consultants and sub-  
23 consultants which Contractor uses in the performance of services under the Agreement  
24 maintain insurance in compliance with this Section unless otherwise agreed in writing by  
25 City's Risk Manager or designee.

26 Prior to the start of performance under the Agreement, Contractor shall  
27 deliver to City certificates of insurance and required endorsements, including any insurance  
28 required of Contractor's subcontractors, consultants and sub-consultants for approval as

1 to sufficiency and form. The certificates and endorsements shall contain the original  
2 signature of a person authorized by that insurer to bind coverage on its behalf. In addition,  
3 Contractor shall, at least thirty (30) days prior to expiration of the insurance required  
4 hereunder, furnish to the City certificates of insurance and endorsements evidencing  
5 renewal of such insurance. City reserves the right to require complete certified copies of  
6 all policies of Contractor and Contractor's subcontractors, consultants and sub-consultants  
7 at any time. Contractor and Contractor's subcontractors, consultants and sub-consultants  
8 shall make available to the City all books, records and other information relating to the  
9 insurance coverage required herein during normal business hours.

10 Any modification or waiver of the insurance requirements herein shall only  
11 be made at the request of City and with the written approval of the City's Risk Manager or  
12 designee. Not more frequently than once a year, the City's Risk Manager or designee may  
13 require that Contractor, Contractor's subcontractors, consultants and sub-consultants  
14 change the amount, scope or types of coverages required herein if, in his or her sole  
15 opinion, the amount, scope, or types of coverages herein are not adequate.

16 The procuring or existence of insurance shall not be construed or deemed  
17 as a limitation on liability relating to Contractor's performance of services or as full  
18 performance of or compliance with the indemnification provisions herein.

19 10. Benefit. This Agreement is intended by the parties to benefit themselves  
20 only and is not in any way intended or entered for the purpose of creating any benefit or  
21 right of any kind for any person or entity that is not a party to this Agreement.

22 11. Non-Discrimination. In connection with performance of this Contract and  
23 subject to applicable rules and regulations, Contractor shall not discriminate against any  
24 employee or applicant for employment on the basis of race, religion, national origin, color,  
25 age, sex, sexual orientation, AIDS, AIDS related condition, handicap, disability, or veteran  
26 status. Contractor shall ensure that applicants are employed, and that employees are  
27 treated during their employment without regard to these bases. Such actions shall include  
28 but not be limited to employment, upgrading, demotion, transfer, recruitment, layoff,

1 termination, rates of pay and selection for training. It is the policy of the Board to  
2 encourage the participation of Disadvantaged, Minority and Women-owned Business  
3 Enterprises and the Board encourages Contractor to use its best efforts to carry out this  
4 policy in the award of all subcontracts.

5 12. This Agreement shall be governed by and construed in accordance with  
6 the laws of the State of California except those provisions relating to conflicts of laws.

7 13. Attorneys Fees. If there is any legal proceeding between the parties to  
8 enforce or interpret this Agreement or to protect or establish any rights or remedies  
9 hereunder, the prevailing party shall be entitled to its costs and expenses, including  
10 reasonable attorney's fees.

11 14. Prevailing Wage Rates. Contractor is directed to the prevailing wage  
12 rates which must be paid for the installation of Units.

13 15. Permits; Construction Bond. Contractor understands that it may be  
14 required to obtain a permit from the City of Long Beach to perform its obligation under this  
15 agreement , and that it is responsible for fulfilling the terms and conditions of such permit  
16 separate from its obligations under this agreement, at its own expense. Contractor agrees  
17 to obtain a construction bond in the amount of \$100,000.00 for the benefit of the City as  
18 a condition of the issuance of such permit.

19 16. Compliance With All Laws and Regulations. Contractor is responsible  
20 for knowing, understanding and complying with all applicable laws and regulations related  
21 to its performance under this Agreement, including but not limited to the Clean Water Act  
22 and related state and local laws and regulations.

23 17. Indemnification. To the fullest extent permitted by law, the Contractor  
24 shall defend, indemnify and hold the City harmless from all claims for bodily injury and  
25 property damage, including resulting loss of use that may arise from the performance of  
26 the Work, arising from or attributable to the negligence or willful misconduct of the  
27 Contractor or anyone employed directly or indirectly Contractor or by anyone for whose  
28 acts any of them may be liable. The Contractor shall not be required to defend, indemnify

Robert E. Shannon  
City Attorney of Long Beach  
333 West Ocean Boulevard  
Long Beach, California 90802-4664  
Telephone (562) 570-2200

1 or hold harmless the City for any acts, omissions or negligence of the City or its  
2 employees, agents or separate contractors.

3 18. Notice. Any notice desired or required shall be in writing and personally  
4 delivered or deposited in the U.S. Postal Service, first class, postage prepaid, addressed  
5 to the Contractor at the address first stated herein, and to the City at 333 W. Ocean Blvd.,  
6 13th Floor, Long Beach CA 90802 attention: City Manager. Change of address shall be  
7 given as provided herein for notices. Notice shall be effective on the date of mailing or on  
8 the date personal service is obtained, whichever first occurs.

9 19. Entire Agreement. This Agreement, including all exhibits, constitutes the  
10 entire understanding between the parties and supersedes all other agreements, oral or  
11 written, with respect to the subject matter herein.

12 20. Governing Law. This agreement shall be subject to and interpreted under  
13 the laws of the State of California.

14 THE PARTIES have executed this Agreement as of the date first provided  
15 above.

16  
17 ASBURY ENVIRONMENTAL SERVICES  
18 a California corporation

19 By [Signature]

20 Title: President

21 By [Signature]

22 Title: Vice President

23 "Contractor"

24  
25 CITY OF LONG BEACH, a municipal  
26 corporation

27 By [Signature]

28 City Manager

"City"

7-9-04, 2004

7-9-04, 2004

7-16-04, 2004

1  
2  
3  
4  
5  
6  
7  
8  
9  
10  
11  
12  
13  
14  
15  
16  
17  
18  
19  
20  
21  
22  
23  
24  
25  
26  
27  
28

The foregoing Agreement is hereby approved as to form this

13<sup>th</sup> day of July, 2004.

ROBERT E. SHANNON, City Attorney

By   
Deputy

Robert E. Shannon  
City Attorney of Long Beach  
333 West Ocean Boulevard  
Long Beach, California 90802-4664  
Telephone (562) 570-2200

**“Exhibit A”**



ORIGINAL FILE COPY

ASBURY ENVIRONMENTAL SERVICES

April 2, 2004

Tom Leary, Stormwater Program Officer  
City Of Long Beach  
Department of Public Works  
333 West Ocean Blvd  
Long Beach Ca, 90802

RE: COST PROPOSAL FOR PURCHASE, INSTALLATION OF SMART SPONGE AND ULTRA URBAN FILTER TECHNOLOGY AND ONE YEAR OF MONITORING INSERT COSTS.

Dear Mr. Leary

Thank you for the opportunity to submit to the City of Long Beach a cost proposal for the purchase, installation of Smart Sponge and Ultra Urban Filters technology and one year of monitoring. Asbury Environmental Services (AES) is the exclusive marketer of these catch basin inserts in California, is pleased to provide to you a low cost, comprehensive solution to the problems associated with bacteria, trash, sediment, and hydrocarbon pollutant runoff through the storm drain system.

Price below is based on product and service needs provided to AES by the City Of Long Beach.. Pricing is based on outfitting 400 sites that average 4 feet in length and will require 3 inserts per catch basin.

**Pricing for Bacteria Media**

400 Sites	\$400.00 X 1200inserts	\$480,000.00
-----------	------------------------	--------------

**Pricing for One Year of Monitoring**

1200 Inserts	\$100.00 X 1200inserts	\$120,000.00 per year
--------------	------------------------	-----------------------

In summary, the average per unit price, over the term of this contract is \$455.00each. If you should have any questions please do not hesitate to contact me at 310-678-8897.

Sincerely,

  
Brian Martello

# ULTRA-URBAN® FILTER CURB OPENING SERIES "CO"

WING TYPE REF.

DESCRIPTION		ILLUSTRATION OF CURB OPENING INSTALLATION	
FINISH	N/A	STD. TOLERANCE UNLESS OTHERWISE NOTED	
MATERIAL SPECIFIED	N/A	X 41	301 243 302 2431 FRAC. 31/32 ANG. 25°
QTY.	ITEM NO.	PART NO.	DESCRIPTION

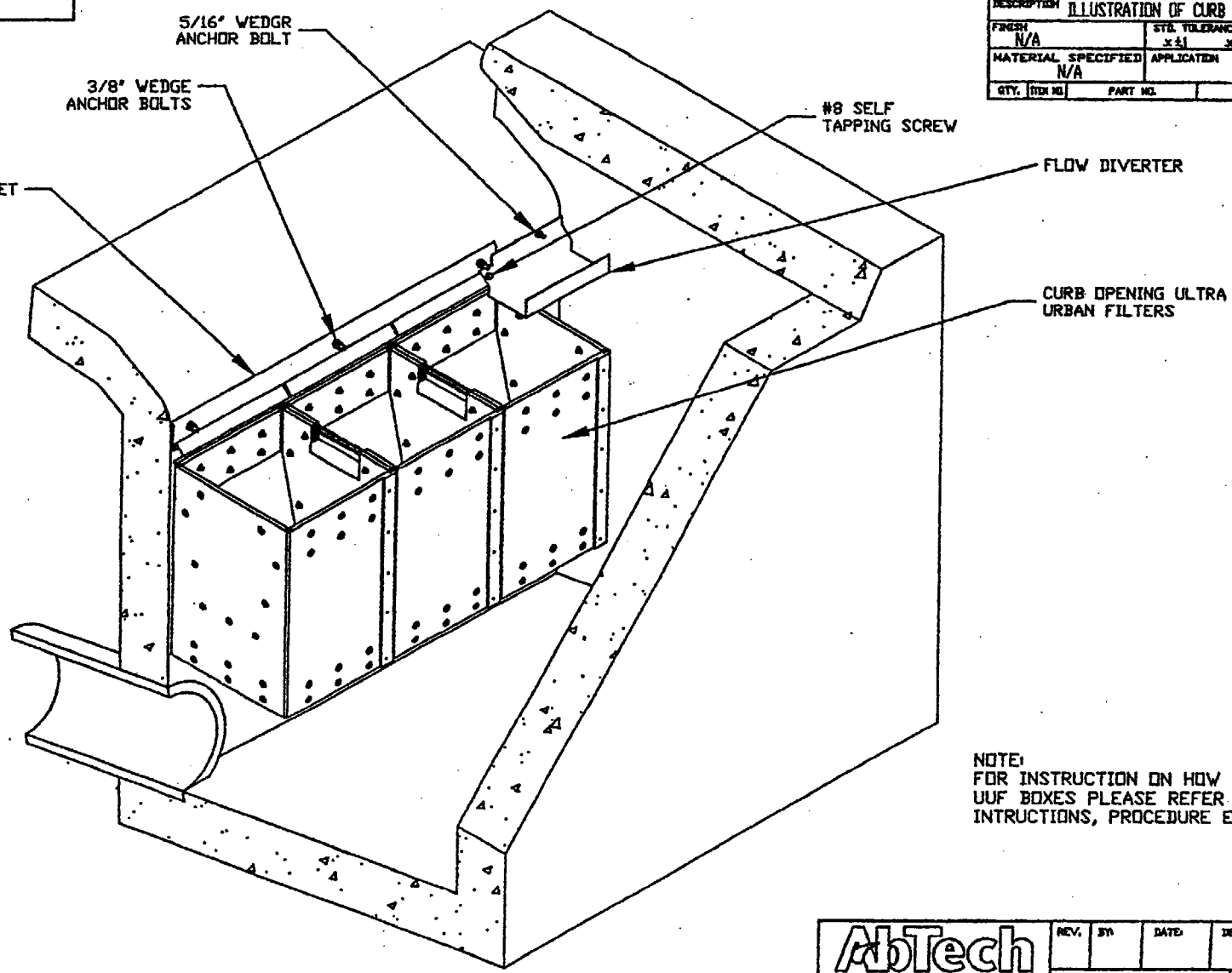

NOTE:  
FOR INSTRUCTION ON HOW TO INSTALL  
UUF BOXES PLEASE REFER TO OUR INSTALLATION  
INSTRUCTIONS, PROCEDURE EP-03

<b>AbTech</b> INDUSTRIES SCOTTSDALE ARIZONA	REV.	BY	DATE	DESCR.
	THIS DRAWING IS DRAWN TO A SCALE OF 1/4" = 1'-0". THE BORDER IS SCALED UP 1. TIMES TO FIT			
			DRAWN BY DATE 08/01	DWG NO. 00508T01



# CO1414N

TYPE PART

DESCRIPTION		13' X 14' X 22.5' UUF COMPLETE ASSEMBLY	
FINISH	STD. TOLERANCE UNLESS OTHERWISE NOTED		
NONE	X ±1	XXX ±.03	FRAG. 1/32 ANG. 15°
MATERIAL SPECIFIED	APPLICATION		
	CO1414N		
QTY.	TRD NO.	PART NO.	DESCRIPTION

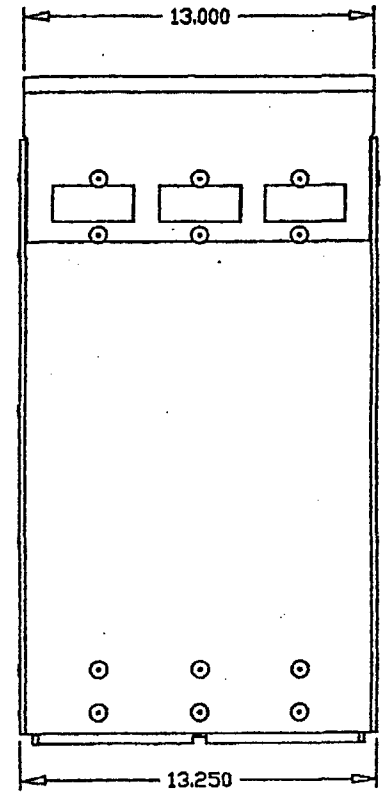
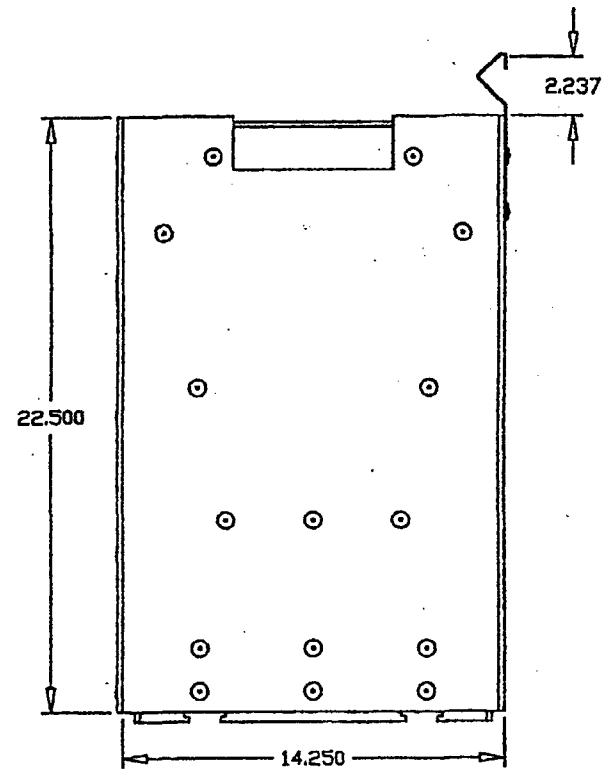
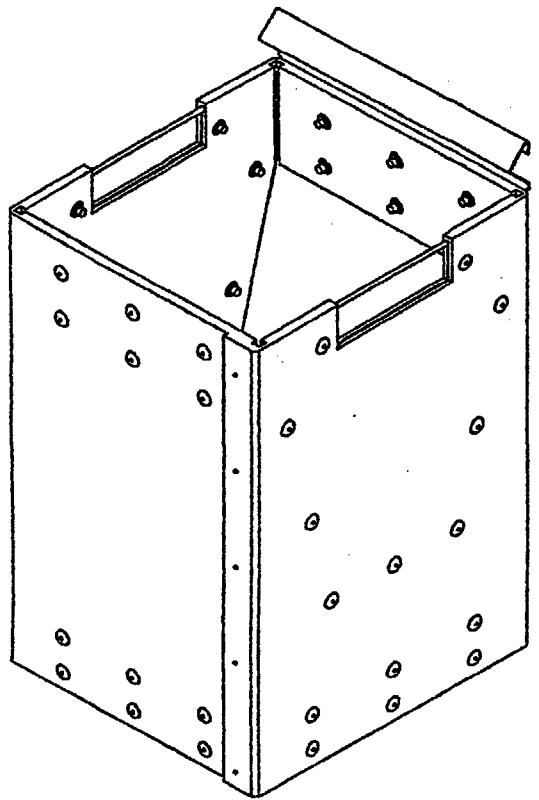

<b>AbTech</b> INDUSTRIES SCOTTSDALE ARIZONA	REV.	BY	DATE	DESCR.
	THIS DRAWING IS DRAWN TO A SCALE OF 1-1. THE BORDER IS SCALED UP 1 TIMES TO FIT			DRAWN BY DATE 6/18/01

# CO1414H

42 TYPE REF.

DESCRIPTION 13' X 14' X 13' UUF	
FRESH NONE	STA. TOLERANCE UNLESS OTHERWISE NOTED X ±1
MATERIAL SPECIFIED N/A	APPLICATOR CO1414H
QTY. (ITEM NO.)	PART NO. DESCRIPTION

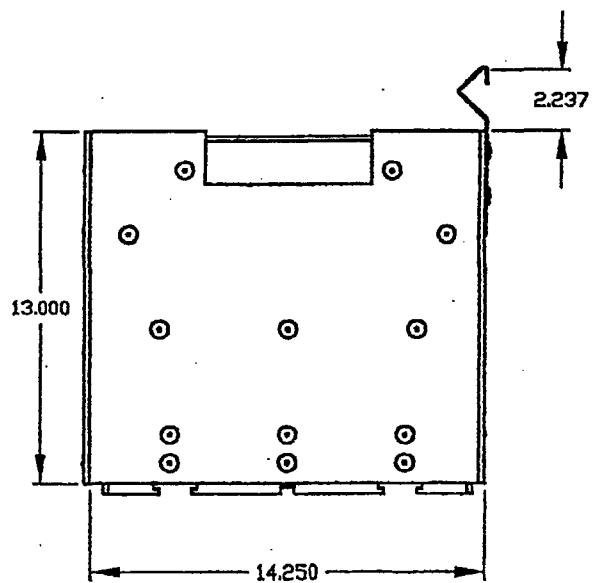
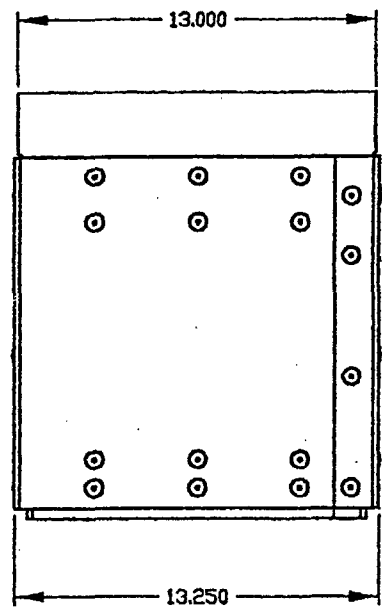
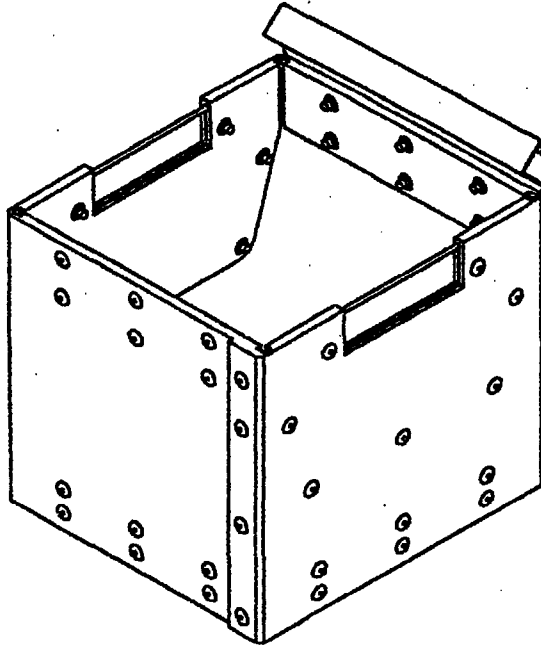

<b>AbTech</b> INDUSTRIES SCOTTSDALE ARIZONA	REV.	BY	DATE	DESCR.
	THIS DRAWING IS DRAWN TO A SCALE OF 1/4". THE NUMBER IS SCALED UP 1 TRIES TO FIT			
DRAWN BY 7/01				DVOR 00606T01

# Ablech CO1414 Ultra Urban Filter Installation Instructions

## 1. Installation of the Mounting Bracket

The location and number of Ultra Urban Filter (UUF) box(es) in each catch basin should be determined by the end user, based on actual flow rates and characteristics of the drain.

- Measure width of the drain opening and the depth of the drain inlet.
- Determine the number of UUF boxes to be installed.
- Determine the length of the bracket, number and location of the holes. Table 1 is meant to provide suggestions.
- Users should follow their own safety protocols and confined space entry procedures.
- Setup the appropriate barriers and traffic control equipment. Remove the drain inlet cover. Make sure the drain is clean and clear of debris.

SUGGESTED LENGTH OF MOUNTING BRACKET AND LOCATION OF HOLES

Number of Boxes	1 to 2	3 to 5	6 - 7	8 to 10
Length of Bracket	Number of boxes times 12.75"	Number of boxes times 13.00"	Number of boxes times 13.125"	Number of boxes times 13.125"
Anch. bolts	2	3	4	5
Location of Anch. Bolts	3" from the edges	6" from the edges + one in the middle	6" and 30" from the edges	12" and 36" from the edges + 1 (middle)

Table 1.

- Use gloves when handling or installing mounting bracket, sharp edges can cause injuries.

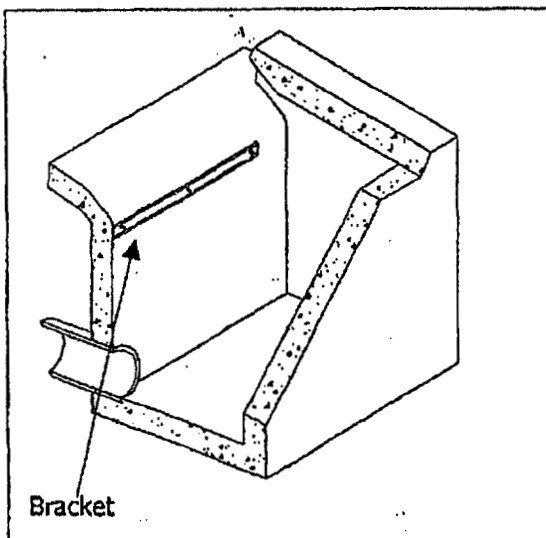

Figure 1.

- Cross-sectional view shown in Figure 2 gives the suggested elevation of anchor bolts and the interference between the bracket's flange and the inlet radius.

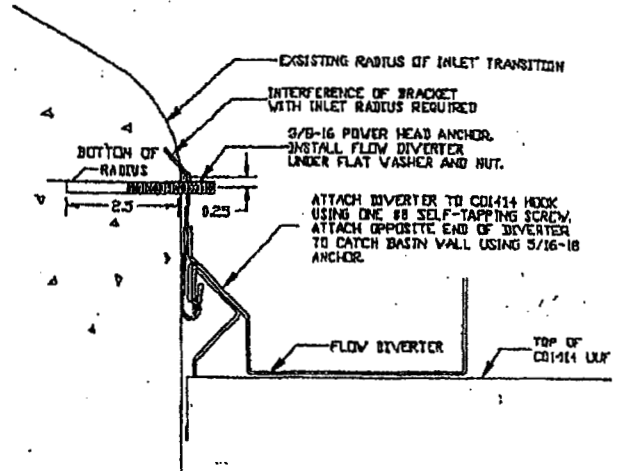

Figure 2.

- UUF Box(es) should be installed so that there is approx. 2"-3" clearance between the bottom of the catch basin and the bottom of the box.
- Use 3/8-16 wedge anchor bolts, 2.25" long, to attach Mounting Bracket to catch basin wall.

## 2. Installation of the UUF Boxes

- UUF boxes should be installed so that the flow through inlet-outlet pipes is not affected.
- Prior installation, remove necessary Over-Flow Cut-Outs to provide openings for lateral overflow between boxes.

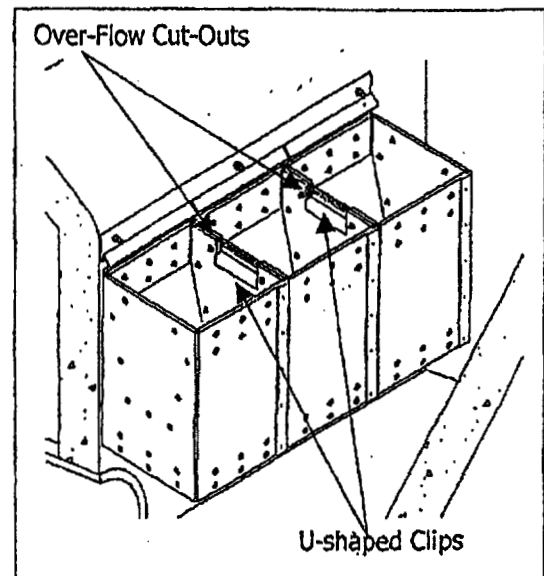

Figure 3.

# AbTech CO1414 Ultra Urban Filter Installation Instructions

- Install U-shaped Clips over the Over-Flow Cut-Outs as shown in figure 3.

## 3. Installation of the Flow Diverter (FD)

- When determining the length of the Flow Diverter, an additional 2" must be added to the length to allow over-flow the UUF box.
- Table 2 is intended to provide suggested number and location for the anchor bolts.
- Users are encouraged to develop and follow their own procedures and safety protocols.
- At approximately 1.5" from the overhanging edge, vertically cut the higher side of the Flow Diverter to approximately 3/16" below the first bend.

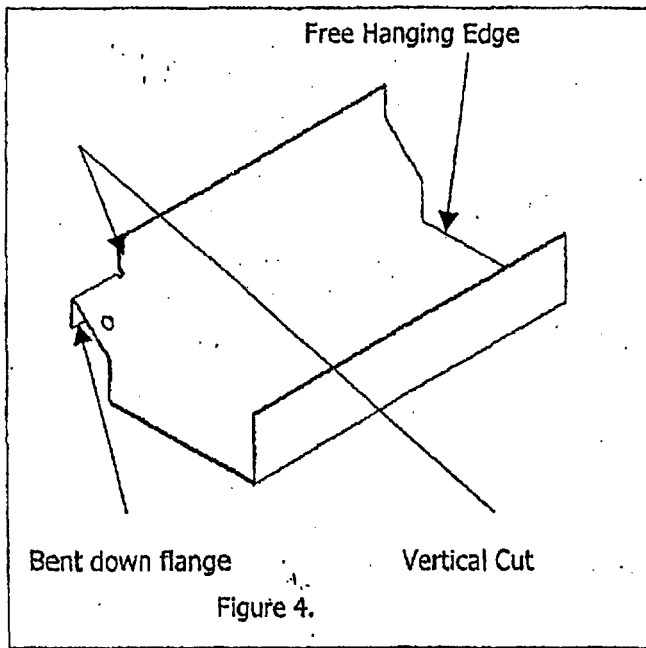

- Use gloves when handling and installing the Flow Diverter, sharp edges can cause injuries.

- Bend down the cut portion of the flange, as shown in figure 4.
- The bent down flange of the Flow Diverter should engage the bracket and sit on top of the hook of the UUF box as shown in figures 2 and 5.
- Use 1/4-20 Wedge Anchor bolts, 2.25" long to secure the Flow Diverter to the catch basin wall.

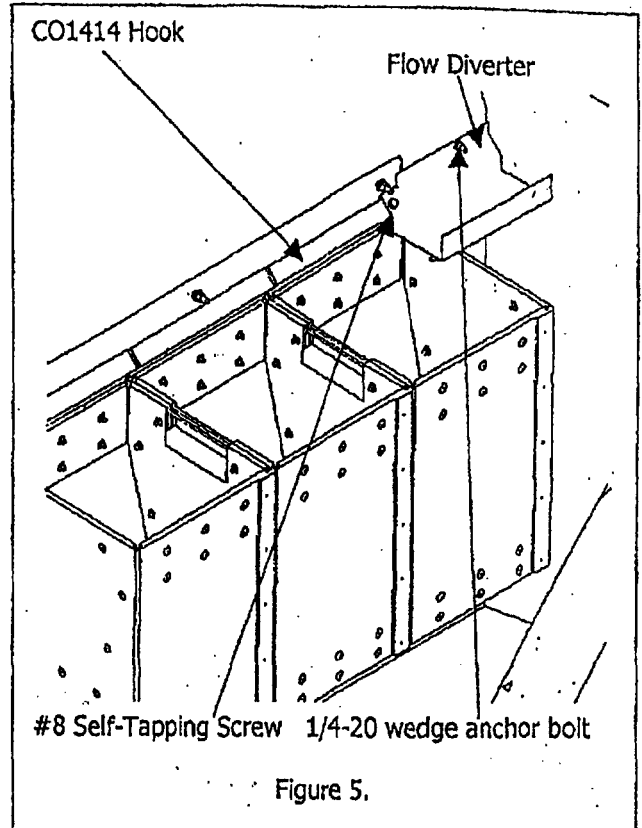

- Secure Flow Diverter to CO1414 Hook using one #8 Self-Tapping screw as shown in figure 5; drilling 3/16" clearance hole may be required.
- Clean up the area and make sure that tools and debris have been removed from the catch basin. Replace the cover to the drain and secure as needed.

SUGGESTED LOCATION OF THE HOLES FOR FLOW DIVERTERS (FD)

FD Length	Less than 3'	3' to 5'	5' to 7'	7 to 11'
Number of Anch. Bolts	1	2	2 - 3	3 - 4
Location of Anch. Bolts	At 3" from the free hanging edge (FH)	At 3" from the (FH) edge and one in the middle	At 3" from the (FH) edge and approx. every 3'	At 3" from the (FH) edge and approx. every 3'

Table 2.

# **“Exhibit B”**

## 1. Urban Runoff Sampling Procedures

This sampling program is aimed at measuring the effectiveness of this Best Management Practice (BMP) by quantifying the amount of bacterial pollutants removed from urban runoff in the areas of the storm drain system identified in this pilot study. Samples will be collected and tested over a period of twenty-four (24) months beginning in October 2004 for the following pollutant of concern: bacteria.

### Procedure:

1. When a rain event of greater than or equal to 0.25 inches is predicted, the AES Sampling Coordinator will notify personnel assigned to sample collection and inform them to prepare for sampling.
2. The lab will be notified by AES when samples have been taken and that they will be delivered within 8-10 hours for lab analysis.
3. As the storm approaches, personnel will report to the site in preparation for the first flush.
4. Once there is flow, first flush samples will be collected from the inlet and outlet points three times during the first flush (0:00,0:15,0:30). The effluent flow (EF) sample will be collected at one (1) thru three (3) minutes after collecting the inlet flow (IF) Sample. Additionally, after the inlet/outlet sampling has been completed one sample will be taken at the end of each storm drain pipe tributary to the Colorado Lagoon.

Refer to the table below for sampling schedule:

Time	Container Type	Sample Volume	Constituents
Start of runoff 0:00	Plastic	125 ml	Fecal Coliform; E. Coli; Entrococcus

Sampling to be repeated according to the above schedule at, 0:15, 0:30, 1:00, 1:30, 2:00, 2:30 (depending on the actual rain duration).

5. At the inlet point<sup>1</sup>, samples are to be scooped off from the gutter runoff. At the outlet point, after the runoff passes through the filter media of the CB insert and filter units, grab samples will be collected by hand within one minute of the influent sampling. Grab sampling will be done at the end-of-pipe locations.
6. Samples to be labeled with date, time, location, and constituents.
7. Samples should be stored in the ice chest, packed with ice, and delivered along with the chain of custody to the Laboratory.

## 2. Gather Equipment

1. Vehicle
2. Disposable gloves
3. Ice chest
4. Ice (necessary to transport sample at 4°C.)
5. Sampling bottle for indicator bacteria (125-mL, autoclaved)

<sup>1</sup> Approximately 10% of the pilot study area IF/EF sites will be randomly selected and tested during each qualifying storm event.

# **AES ASBURY ENVIRONMENTAL SERVICES**

6. Sampling labels
7. Field collection sheet
8. Indelible marker
9. Nylon rope (25 ft. of 1/8 in. line)
10. Sampling weight (4-8 oz.)

### **3. Sampling Location**

Manual sampling will be performed for the collection of bacteria samples. Grab samples will be collected from the incoming surface flow prior to contact with Smart Sponge® polymer and effluent flow after contact with treatment unit. The influent flow will be collected with a sterilized plastic bottle. The effluent sample will be collected from the outlet point and at the end-of-pipe at each of the outfall pipes tributary to the Colorado Lagoon with a sampling pole. The laboratory bottle will be attached to the sample pole and lowered into the drain for effluent collection. Traffic controls must be considered and safety measures in place prior to sampling. Follow all safety rules when working in or near the public right of way.

### **4. Sample Scheduling**

The coordination of resources for proper sample receiving and testing will be such that sample arrival times will be arranged to allow enough time for lab personnel to properly begin the Idexx Quanti-tray testing for total coliform, E-Coli, and Enterococcus.

### **5. Sampling**

Sampling will be conducted from the street level or in the drain depending on the drain size. Sampling individuals must handle all sample bottles carefully to avoid cross-contamination. When on-site, the general plan for sampling a drain is:

- a) Label the bottles with the waterproof labels using an indelible marker.
- b) Collect grab sample bacterial testing:
  - Use the nylon line and sampling weight to make a rope loop around the 125-mL sampling bottle for lowering into the wet well. The weight is necessary to overcome the buoyancy of the empty bottles.
  - Record collection time.
  - Place sample on ice in ice chest.
- c) Deliver samples for laboratory testing:
  - Drive to the EMD Microbiology Lab at:  
12000 Vista Del Mar – Pregerson Building, 4<sup>th</sup> floor.
  - Relinquish samples to lab personnel with the appropriate signatures at the bottom of the field collection sheet.
  - Leave the signed field collection sheet with lab personnel for sample login and tracking.
  - Fill out Chain of Custody (COC) form provided by WPD.
  - For bacterial testing, request that the 125-mL bottle be tested for total coliform, E-Coli, and Enterococcus using the Chromogenic method.

### **6. Dry weather sampling**

# **AES ASBURY ENVIRONMENTAL SERVICES**

Simulated dry weather sampling may be necessary during this period in order to reach a statistically meaningful number of samples. A flow rate of fifteen gallons (30/gallons per minute) shall be maintained during through out the sampling process.

## **7. Safety**

When sampling, be alert to the potential dangers around you. Pay attention to your footing. Use common sense when determining whether a sampling situation is safe or not. If conditions are not safe, do not sample the site. Record this information on the field collection sheet.

## **8. Maximum Number of Sampling Events**

A maximum of 12 rainfall events over the 24 month trial period may be sampled. The rainfall depth for the event, measured at the site, must be greater than or equal to 0.25 inches. Grab samples will be collected for the influent, effluent and end-of-pipe locations over the duration of the runoff event. There shall be a minimum of 72 hours between qualified sampling events. Rain events that are considered for sampling are: 1) if 0.25 inch of rain or greater is predicted, and 2) if there is a dry period of at least 72 hours preceding the rain event to increase the likelihood that pollutant levels would be detectable.

## **9. Decontamination**

Decontamination of the sampling equipment will be necessary so that no residual concentrations of contaminants exist within sample bottles and other equipment. Use sterilized bottles.

Sh-/revised 01/15/2004



**AES Catch Basin Inserts  
Monitoring Data Sheets  
(City of Long Beach)**

Date of Cleaning	Record #	Contr. #	Thomas Guide Pg. & Gr.	City	Abtech Installation Location	Volume of Litter to the Quarter Gallon (excluding sediment & vegetation)	Weight of Litter to the Ounce (excluding Sediment & vegetation)	Volume of Sediment & Vegetation to the Quarter Gallon (excluding litter)	Weight of Sediment & Vegetation to the Ounce (excluding litter)	Land Use
						0	0	0	0	
<b>LAND USE TOTALS</b>						0	0	0	0	

**Sample Reporting Form**

1 FIRST AMENDMENT  
2 TO CONTRACT NO. 28831  
3

4 THIS FIRST AMENDMENT to Contract No. 28831, by and between ASBURY  
5 ENVIRONMENTAL SERVICES, a California corporation, ("Contractor") with its principal  
6 place of business at 2100 N. Alameda, Compton, California 90222, and THE CITY OF  
7 LONG BEACH, a municipal corporation ("City,") is made and entered, in duplicate, as of  
8 NOVEMBER 16, 2005, for reference purposes only, pursuant to a minute order of the City  
9 Council at its meeting held on September 20, 2005.

10 WHEREAS, the parties entered Contract No. 28831 for furnishing, installing  
11 and monitoring Smart Sponge and Ultra Urban Filter Technology catch basin inserts ("the  
12 Work"); and

13 WHEREAS, the parties desire to extend the term of said Contract; and

14 NOW, THEREFORE, in consideration of the mutual terms and conditions in  
15 Contract No. 28831 and herein, the parties agree as follows:

16 1. The term of Contract No. 28831 shall be extended for twelve (12) months  
17 and shall expire on September 30, 2006.

18 2. The expenditures under Contract No. 28831 shall not exceed the original  
19 contract amount. The City does not guarantee that the full amount shall be expended; the  
20 City's expenditures are based on its needs and requirements and the amount and nature  
21 of the services performed by Contractor.

22 3. Except as expressly amended herein, all of the terms and conditions in  
23 Contract No. 28831 are ratified and confirmed and shall remain in full force and effect.

24 ////

25 ////

26 ////

27 ////

28 ////

Robert E. Shannon  
City Attorney of Long Beach  
333 West Ocean Boulevard  
Long Beach, California 90802-4664  
Telephone (562) 570-2200

1  
2  
3  
4  
5  
6  
7  
8  
9  
10  
11  
12  
13  
14  
15  
16  
17  
18  
19  
20  
21  
22  
23  
24  
25  
26  
27  
28

The Parties have executed this Agreement as of the date first provided above.

ASBURY ENVIRONMENTAL SERVICES  
a California corporation

11/14/, 2005

By [Signature]  
Title: President

11/14, 2005

By [Signature]  
Title: [Signature]  
"Contractor"

CITY OF LONG BEACH, a municipal  
corporation

11/30, 2005

By [Signature]  
City Manager  
"City"

The foregoing Agreement is hereby approved as to form this

21<sup>st</sup> day of November, 2005.

ROBERT E. SHANNON, City Attorney

By [Signature]  
Deputy

Robert E. Shannon  
City Attorney of Long Beach  
333 West Ocean Boulevard  
Long Beach, California 90802-4664  
Telephone (562) 570-2200

LPM:et

09/30/05; 10/03/05

05-04656

L:\APPS\CtyLaw\32\WPDOCS\ID030\P004\00080328.WPD