

OFFICE OF THE CITY ATTORNEY
CHARLES PARKIN, City Attorney
411 West Ocean Boulevard, 9th Floor
Long Beach, CA 90802-4664

1 **MEMORANDUM OF UNDERSTANDING**
2 **36279**

3 This Memorandum of Understanding ("Agreement") is made and entered into as of
4 June 01, 2022, for reference purposes only, pursuant to a minute order adopted by the
5 City Council of the City of Long Beach at its meeting on May 24, 2022, by and between
6 the CITY OF LONG BEACH, a municipal corporation ("City"), and THE LONG BEACH
7 YACHT CLUB, a California corporation, ("LBYC", and together with City, the "Parties", or
8 individually, a "Party").

9 **RECITALS**

10 WHEREAS, the Mission of Long Beach Yacht Club is to promote
11 yachting and competitive sportsmanship on a world-class level. Since 1929, LBYC has
12 grown not only in membership, but also in reputation in the yachting community. A large
13 contributor to such growth is the LBYC's longstanding commitment to developing sailors
14 and recreational boaters. LBYC's commitment to developing youth, or Junior Sailors, is
15 evident by steadily increasing participation in its summer programs and regattas, and
16 local community outreach programs; and

17 WHEREAS, with permission of the City, LBYC has used City property at the
18 northwest end of Basin Four in Alamitos Bay Marina to operate its LBYC Junior Sailing
19 program; and

20 WHEREAS, LBYC's Junior Sailing program has grown to the point where
21 LBYC finds it necessary to improve its Junior Sailing facilities to make instruction and
22 participation more efficient, safe, and effective – by moving the majority of single-handed
23 and double-handed boats to a floating dock located in front of the LBYC clubhouse, while
24 the higher performance program sailboats and coaching vessels will remain stored at the
25 dock and boat storage area at the northwest end of Basin Four. Adding Sabot storage to
26 the front of the club will enable LBYC to further centralize the Junior Sailing program and
27 related events. An existing paddle board rack can be improved and moved during the
28 process. After significant research, including input from the City, LBYC Board of

1 Directors approved such a plan, along with required funding. Such plan is attached
2 hereto as **Attachment A**; and

3 WHEREAS, the City is the proprietor and manager of Long Beach Marinas
4 pursuant to rules and regulations set forth in the provisions of Section 16.08.970 of the
5 Long Beach Municipal Code, which directs the City to implement, make specific, and
6 otherwise carry out the policy of maintaining the Long Beach Marinas in a sanitary,
7 sightly, and orderly condition and of preserving the public health, safety, peace, welfare,
8 and convenience in the use thereof; and

9 WHEREAS, the berthing of vessels, installation of docks, and any other
10 improvements set forth in this MOU are within the City's above-stated directive to
11 "implement, make specific, and otherwise carry out the policy of maintaining the Long
12 Beach Marinas in a sanitary, sightly, and orderly condition and of preserving the public
13 health, safety, peace, welfare, and convenience in the use thereof."; and

14 WHEREAS, the purpose of this MOU is to set forth where and how LBYC
15 will: install, use and maintain new floating dock located in front of LBYC clubhouse;
16 improve and maintain current floating dock located at northwest end of Basin Four in
17 Alamitos Bay Marina; add additional Sabot storage in front of LBYC clubhouse; and store
18 floating dock when not in use.

19 **AGREEMENT**

20 NOW THEREFORE, in consideration of the mutual obligations of the
21 Parties to each other, the Parties agree as follows:

22 **1. LBYC's Responsibilities.** Floating Dock in Front of The Long Beach Yacht Club
23 6201 E. Appian Way Long Beach, CA 90803; 33.44.5 N, 118.07.18 W: In water dock
24 enhancement will consist solely of one (1) single row floating dock and one (1) multi-
25 purpose launch area (see **Attachment B**).

26 a. Single row/multipurpose floating dock will be temporary; deployed
27 from June 1 through Labor Day of each calendar year.

28 b. During non-deployment period floating dock and components must

1 be removed from the water and stored off site and inconspicuously.

2 c. Floating dock must fasten with cleats.

3 d. City to provide cleats on main dock as needed, LBYC bears all other
4 cost of installation and maintenance.

5 e. LBYC will provide fender material between floating dock and main
6 dock to protect both.

7 f. LBYC to provide ramping from main dock to floating dock.

8 **2. Floating Dock Replacement at Basin 4 Long Dock**. In water dock
9 replacement will consist solely of one (1) single row floating dock (see **Attachment C**).

10 a. Floating dock shall be the same length as existing dock (60 ft.), with
11 one additional cube of dock to width per Attachment C.

12 b. Existing mounting bracket locations shall be used. Brackets shall be
13 replaced as necessary upon installation.

14 c. LBYC bears cost of installation and maintenance.

15 d. LBYC to provide ramping between main dock and floating dock.

16 **3. Sabot Storage and Paddleboard Storage Racks on Floats**. Must be built to
17 exact specifications as existing racks by Bellingham Marine or alternative contractor, as
18 approved by City. LBYC shall submit plans, designs and specifications for all materials
19 to be used prior to any initiation of project mobilization.

20 **4. Other General Responsibilities of LBYC:**

21 a. LBYC shall be responsible for all purchase, installation, removal, and
22 storage of floating dock that is the subject of this MOU.

23 b. Any temporary structures remaining in place on Long Beach Marinas
24 property after Labor Day of each calendar year will be removed, stored, and discarded by
25 Marine Bureau staff at the sole expense of LBYC.

26 c. LBYC to obtain City required insurance and provide proof to City
27 thereof prior to beginning any project contemplated under this MOU.

28 d. Dock enhancement and installation plans and design/specifications

1 for all materials utilized shall be approved by City prior to project mobilization. Such
2 plans area attached hereto as **Attachment D**.

3 e. No other dock or area enhancements may be installed without prior
4 written approval from the City.

5 f. Community Benefit: Long Beach Yacht Club shall, each summer,
6 advertise and hold a public open house for Long Beach area youth aged 7 to 16. At this
7 event, to be scheduled on a Saturday between June 1 and Labor Day of each year,
8 LBYC will open their youth sailing program to the public to promote sailing and introduce
9 attendees from the greater Long Beach area to watersports offered at LBYC.

10 **5. City's Responsibilities:**

11 a. To permit the installation, deployment, use, maintenance and
12 dismantling/removal of the aforementioned floating docks in accordance with the terms
13 above.

14 b. To install cleats on Marina property as needed for this project,
15 subject to approval of Marina supervisor.

16 **6. Schedule.** Installation schedule is provided hereto as Attachment D.

17 **7. Term.** This MOU shall be in full force and effect upon signature of all Parties
18 following their respective authorization processes. The term of this MOU shall expire on
19 December 31, 2032, unless terminated as set forth in Section 8.

20 **8. Termination.** Either Party shall provide 90 days advanced written notice of
21 termination of this MOU for any reason. LBYC shall be responsible for removal of any
22 and all floating docks contemplated by this MOU before the end of the aforementioned
23 termination period (within 90 days of notice of termination, or longer period if specified),
24 and shall retain ownership after such termination.

25 **9. Indemnity.** LBYC shall defend, indemnify and hold harmless City from all claims,
26 demands, damages, causes of action, losses, liability, costs or expenses, including
27 reasonable attorney's fees, of any kind or nature whatsoever (collectively referred to in
28 this Section as "claims") which City may incur for injury to or death of persons or damage

1 to or loss of property due to the alleged acts or omissions of LBYC, LBYC's employees,
2 or agents, or any breach of this Agreement by LBYC.

3 **10. Force Majeure.** If either Party shall be delayed or prevented from the
4 performance of any act required hereunder by reason of acts of God, restrictive
5 governmental laws or regulations or other cause, without fault and beyond the
6 reasonable control of the Party obligated, performance of such-act shall be excused for
7 the period of the delay; and the period for the performance of any such act shall be
8 extended for a period equivalent to the period of such delay.

9 **11. Amendments.** This Agreement shall not be amended, nor any provision or
10 breach hereof waived, except in writing signed by the parties which expressly refers to
11 this Agreement.

12 **12. Governing Law.** This Agreement shall be governed by and construed pursuant to
13 the laws of the State of California.

14 **13. Entire Agreement.** This Agreement constitutes the entire understanding between
15 the Parties and supersedes all other agreements, oral or written, with respect to the
16 subject matter contained herein.

17 **14. Costs.** If there is any legal proceeding between the Parties to enforce or interpret
18 this Agreement or to protect or establish any rights or remedies hereunder, the prevailing
19 party shall be entitled to its costs and expenses, including reasonable attorneys' fees and
20 court costs.

21 **15. Nondiscrimination.** In connection with performance of this Agreement and
22 subject to applicable rules and regulations, the Parties shall not discriminate against any
23 employee or applicant for employment because of race, religion, national origin, color,
24 age, gender, sexual orientation, AIDS, AIDS related condition, handicap, disability or
25 Vietnam Era veteran status. The Parties shall ensure that applicants are employed, and
26 that employees are treated during their employment, without regard to these bases.
27 Such actions shall include, but not be limited to, the following: Employment, upgrading,
28 demotion or transfer, recruitment or recruitment advertising, layoff or termination, rates of

1 pay or other forms of compensation, and selection for training, including apprenticeship.
2 **16. Notices.** Any notice or approval required hereunder by any Party shall be in
3 writing and personally delivered or deposited in the U.S. Postal Service, first class,
4 postage prepaid, addressed to each Party at the respective addresses stated below.
5 Notice of change of address shall be given in the same manner as stated herein for other
6 notices. Notice shall be deemed given three (3) business days after said writing is
7 deposited in the mail or on the date personal delivery is made, whichever first occurs.

8 City of Long Beach
411 W. Ocean Blvd., 9th Floor
9 Long Beach, California 90802
10 Attention: City Manager

11 with a copy to:

12 City of Long Beach
205 Marina Drive
13 Long Beach, California 90803
Attention: Marine Bureau Manager

14 The Long Beach Yacht Club
6201 E. Appian Way
15 Long Beach, California 90803
16 Attention: Commodore

17 **17. Continuation.** Termination or expiration of this Agreement shall not affect rights
18 of City under Sections 3 or 5 which accrued prior to termination or expiration of this
19 Agreement.

20 **18. Non-Party Beneficiary.** This Agreement is intended by the Parties to benefit
21 themselves only and is not in any way intended or designed to or entered for the purpose
22 of creating any benefit or right for any person or entity of any kind that is not a Party to
23 this Agreement.

24 **19. Successors.** This Agreement shall inure to the benefit of, and be binding upon,
25 the Parties and their respective successors and permitted assignees.

26 **20. Counterparts.** This Agreement may be executed in several counterparts, and all
27 so executed shall constitute one agreement, binding on the Parties, notwithstanding that
28 all Parties are not signatory to the original or the same counterpart.

OFFICE OF THE CITY ATTORNEY
CHARLES PARKIN, City Attorney
411 West Ocean Boulevard, 9th Floor
Long Beach, CA 90802-4664

1 **21. Headings.** The headings contained in this Agreement are for reference purposes
2 only and shall not affect the meaning or interpretation of anything contained in this
3 Agreement.

4 **22. Early Termination.** Notwithstanding anything to the contrary contained herein,
5 City shall have the right to terminate this Agreement if any third-party threatens a lawsuit
6 over the subject matter of this Agreement and City reasonably determines that such
7 threatened lawsuit is not without merit.

8 **23. Authority.** The persons executing this Agreement on behalf of City and LBYC
9 represent and warrant that they have the authority to execute this Agreement in the
10 capacity indicated next to their respective signatures.

11 ///

12 ///

13 IN WITNESS WHEREOF, the parties have caused this Agreement to be
14 duly executed with all formalities required by law as of the date first stated herein.

15
16 THE LONG BEACH YACHT CLUB, a
California corporation

17 May 31, 2022

By [Signature]
Name Joe A. Frigniatto
Title Commandore

18
19
20 May 31, 2022

By [Signature]
Name Blair Carby
Title Vice Commandore

21 "Contractor"

22
23 CITY OF LONG BEACH, a municipal
24 corporation

25 _____, 2022

By _____
City Manager

26 "City"

27
28

OFFICE OF THE CITY ATTORNEY
CHARLES PARKIN, City Attorney
411 West Ocean Boulevard, 9th Floor
Long Beach, CA 90802-4664

1 **21. Headings.** The headings contained in this Agreement are for reference purposes
2 only and shall not affect the meaning or interpretation of anything contained in this
3 Agreement.

4 **22. Early Termination.** Notwithstanding anything to the contrary contained herein,
5 City shall have the right to terminate this Agreement if any third-party threatens a lawsuit
6 over the subject matter of this Agreement and City reasonably determines that such
7 threatened lawsuit is not without merit.

8 **23. Authority.** The persons executing this Agreement on behalf of City and LBYC
9 represent and warrant that they have the authority to execute this Agreement in the
10 capacity indicated next to their respective signatures.

11 ///
12 ///

13 IN WITNESS WHEREOF, the parties have caused this Agreement to be
14 duly executed with all formalities required by law as of the date first stated herein.

15
16
17 May 31, 2022

THE LONG BEACH YACHT CLUB, a
California corporation

By [Signature]
Name Joe A. Tringali
Title Commander

18
19
20 May 31, 2022

By [Signature]
Name Blair Carby
Title Vice Commander

"Contractor"

21
22
23
24 June 8, 2022

CITY OF LONG BEACH, a municipal
corporation

By [Signature]
City Manager

"City"

EXECUTED PURSUANT
TO SECTION 301 OF
THE CITY CHARTER.

APPROVED AS TO FORM
On: June 6, 2022
For: CHARLES PARKIN,
City Attorney
By: [Signature]
Deputy City Attorney

ATTACHMENT A

LONG BEACH YACHT CLUB

JUNIOR SAILING AND ONE DESIGN FACILITY IMPROVEMENT PROPOSAL

Justin Palm

Sailor Development Chair

Steve Meyer, Mike Tande

Yachting Committee Co-Chairs

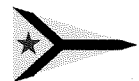

LBYC SAILOR DEVELOPMENT : PRIORITIES

1. Juniors (8 to 18)
2. Collegiate
3. Age 22 and over (“Adult”)
4. Women’s Sailing

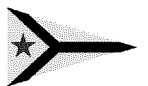

BACKGROUND:

- Current Setup: LBYC Junior Program and One Design Fleets split locations
- Front of LBYC clubhouse:
 - Sabot racks on rafts (Junior use), coach and umpire boats
- LBYC Clubhouse:
 - Sailing Offices (coaches), Junior room, gathering areas for instruction, clinics and regattas

EXISTING LBYC CLUB WATER FRONT SETUP



Coach/Umpire Boats

Sabot Racks on Rafts

BACKGROUND CONT:

- Sea Base:
 - All Double-handed Junior boats (420, FJ, RS Feva), Lasers, part of Sabots and One Design Fleets.
 - Sea Scouts = subset of Boy Scouts ages 14-20

- Current setup
 - Logistics challenge for children, parents and coaches going between Sea Base and Club house for instruction
 - Time
 - Safety

EXISTING SEA BASE SETUP



BACKGROUND – CONT.

- Sea Base better situated and configurable to One Design fleet sailing center:
 - Older Junior and Local One Design Fleets
 - Olympic Classes, Technical One Designs
 - LBYC would like to participate and partner with City of Long Beach and other stakeholders to plan and manage.
- Other Factors
 - USOC
 - Sea Base Lease
 - Umpire Boats

PROPOSAL

1. CENTRALIZE LBYC JUNIOR SAILING LOCATION FOR INSTRUCTION

2. CENTRALIZE/UPDATE SEABASE FOR ONE DESIGN SAILING/EVENTS/ADVANCED SAILING

#1 MOVE SABOTS, FJ, 420,
FEVA TO LBYC CLUB FRONT

- VIA FLOATING DOCK AND
SABOT RACKS

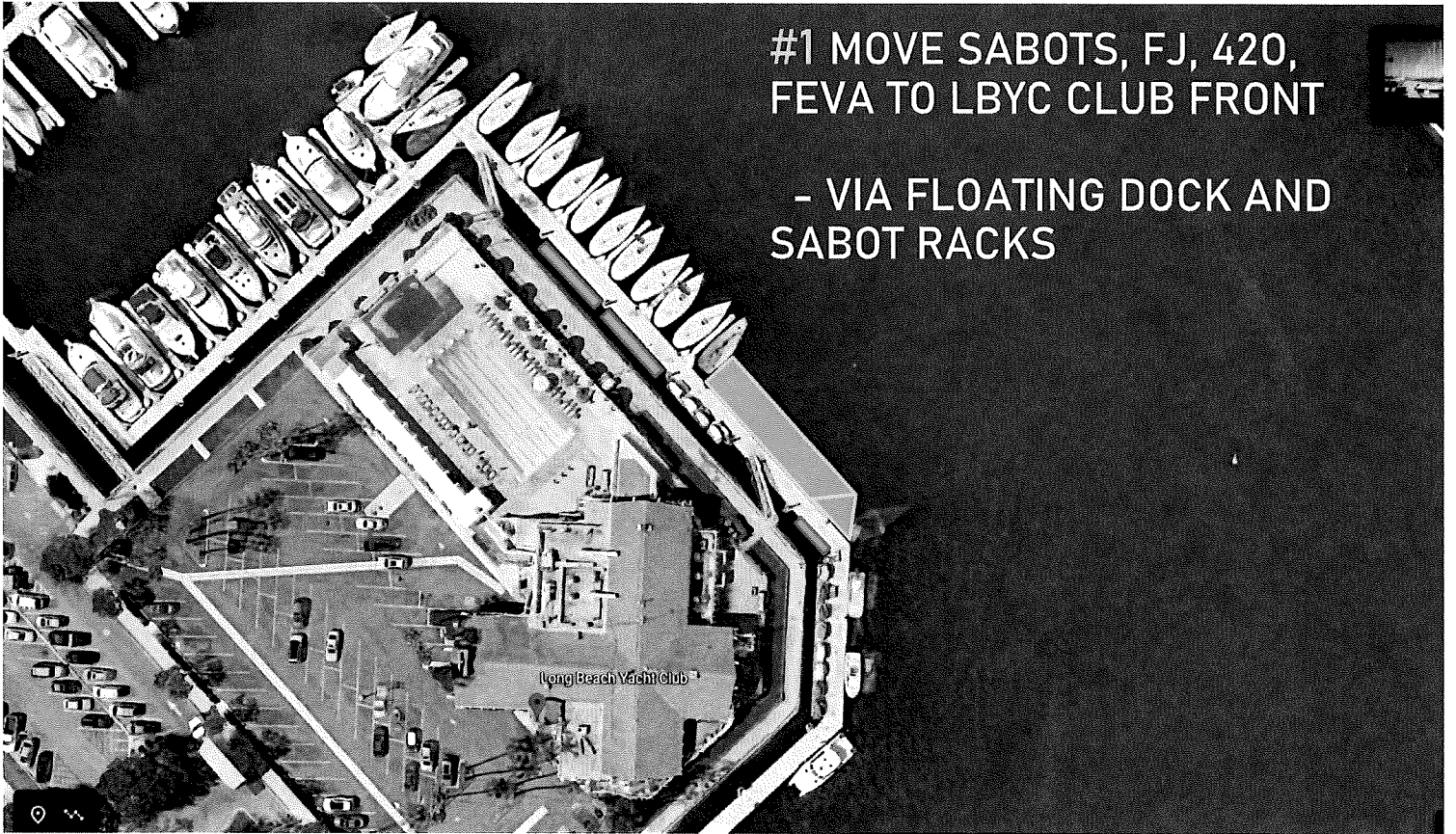

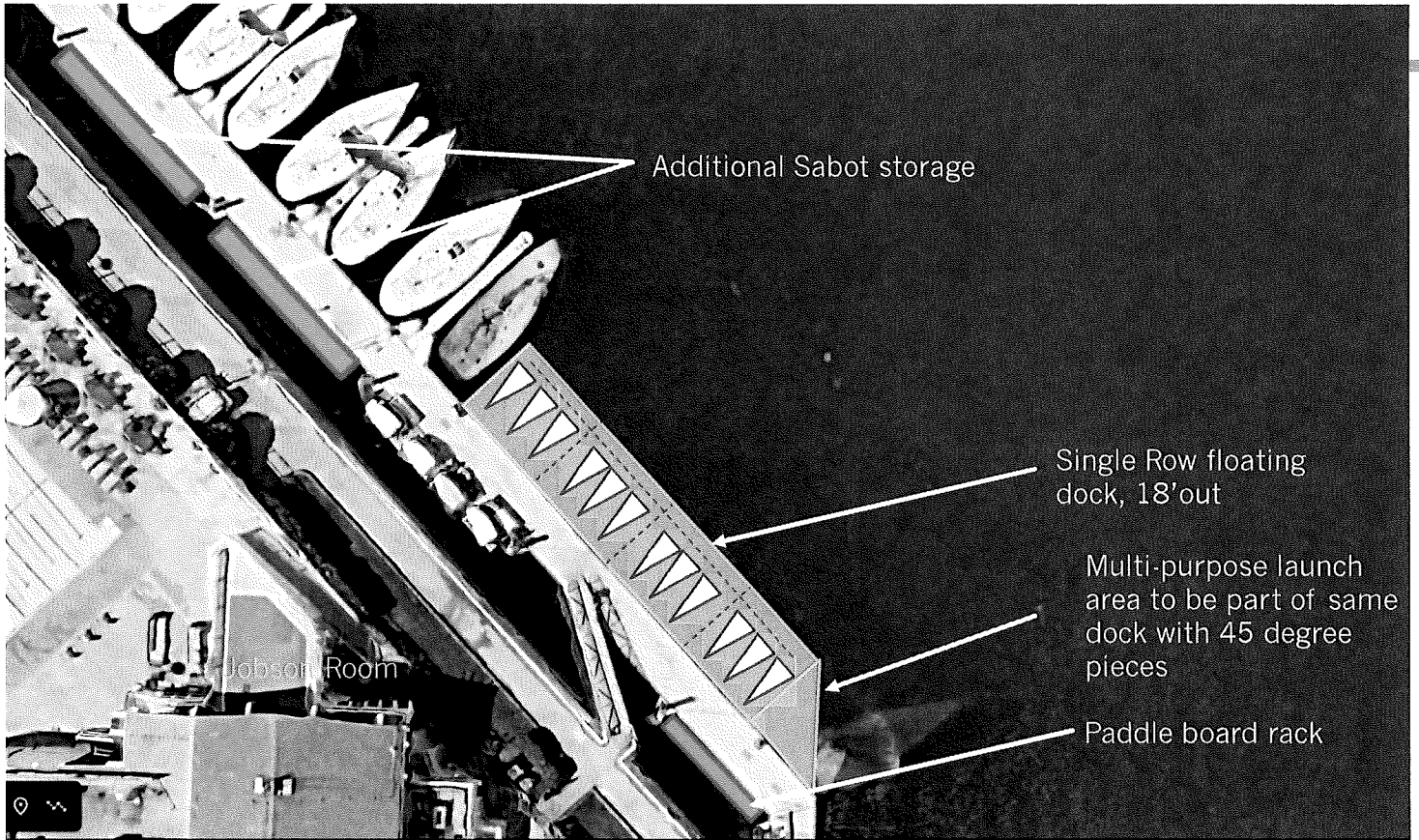

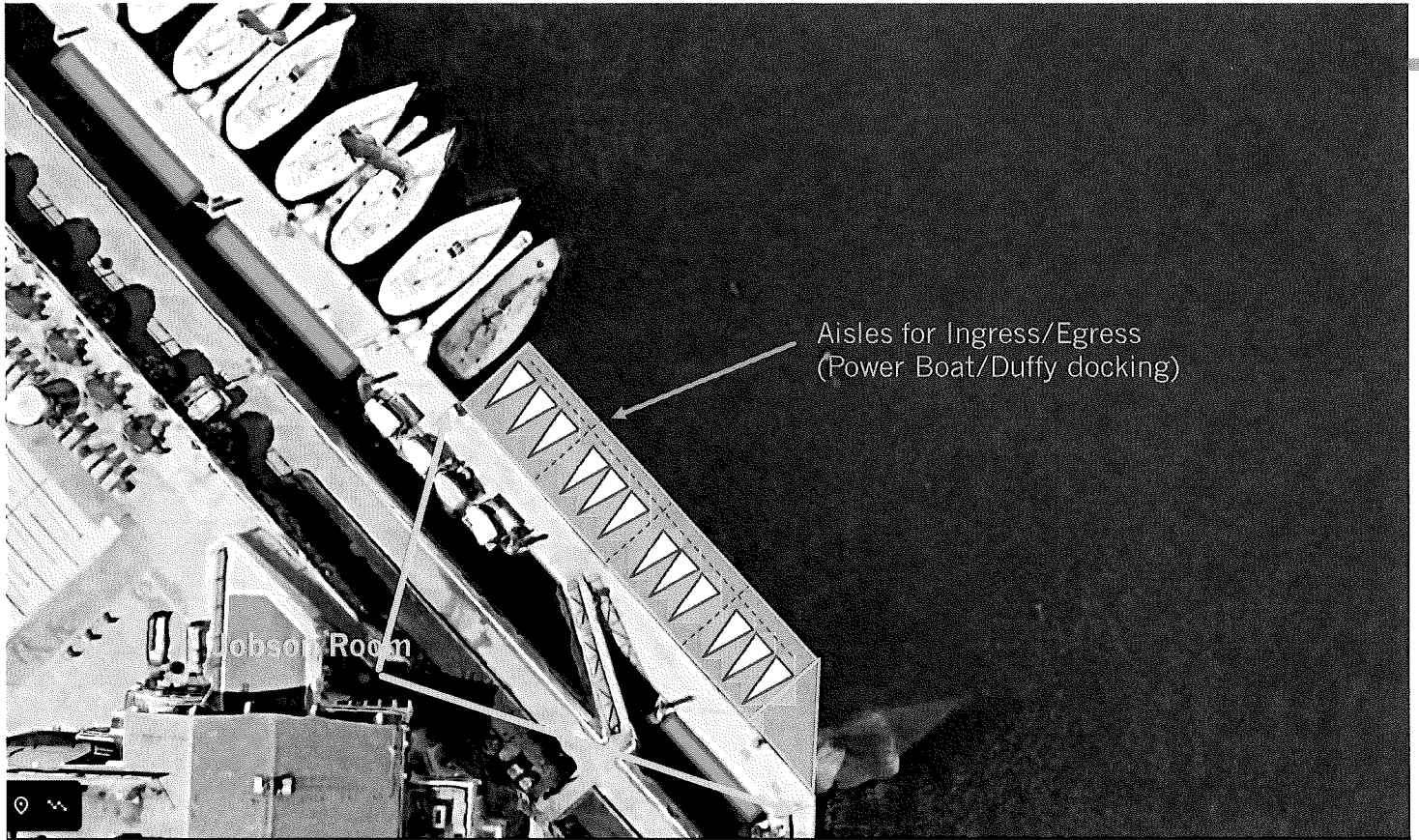

Aisles for Ingress/Egress
(Power Boat/Duffy docking)

Jobson Room

FLOATING DOCK DIMENSIONS

Re-Purpose
Existing dock at
Sea Base

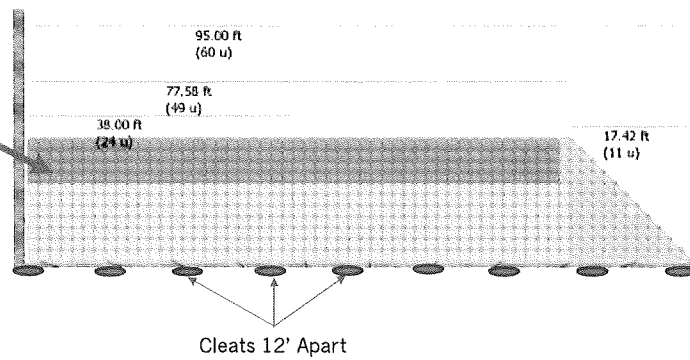

FLOATING DOCK

1/2 pieces at 45 degrees will lock in place for one piece float



FLOATING & SABOT DOCK –CONDITIONS PER CITY OF L.B.

DIRECTOR OF MARINE OPERATIONS

VIA SCOTT DIXON, FLEET CAPTAIN

1. Temporary – Can be used from June 1 through Labor Day and then must be removed.
2. Floating Dock must fasten with Cleats (City to provide cleats as needed, LBYC bears all other cost of floating dock and installation)
3. Must provide fender material between Floating Dock and Main Dock to protect both
4. Must have ramping from Main Dock to Floating Dock
5. Must take safety precautions with cleats after fastening (covers/paint color, etc.)
6. Proposal to Include Design specs/Cut sheets – (some attached)
7. LBYC to obtain appropriate insurance and provide proof thereof.
8. Additional Sabot Racks on floats – must be built by Bellingham in accordance with specs of existing Sabot Racks (width and height, length TBD by space)

CLEATS - EXAMPLE

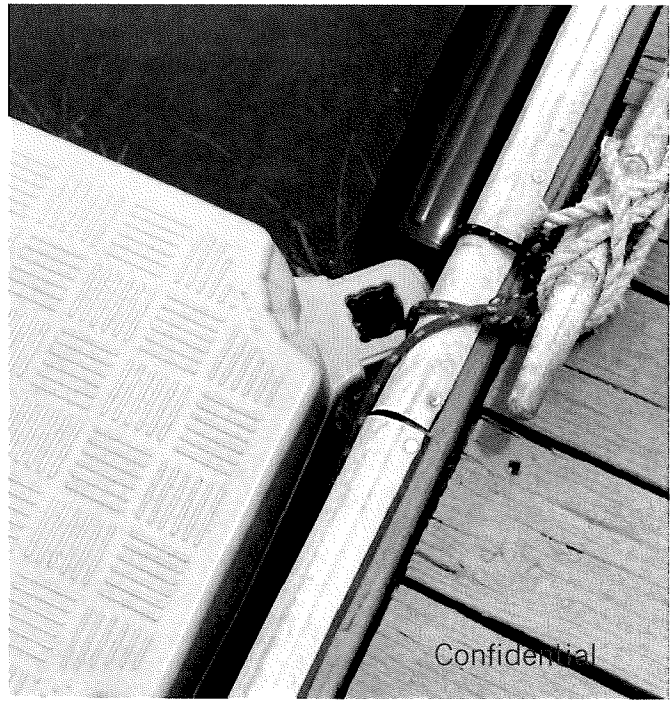
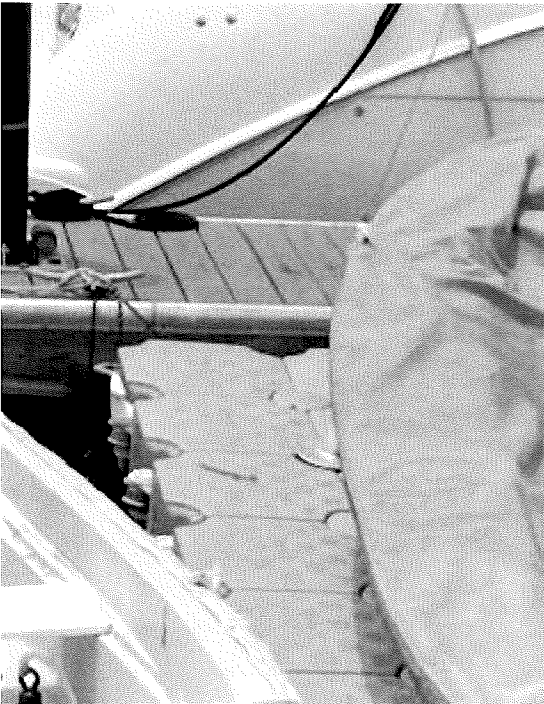

Confidential

RAMP BETWEEN MAIN AND FLOATING DOCKS - EXAMPLE

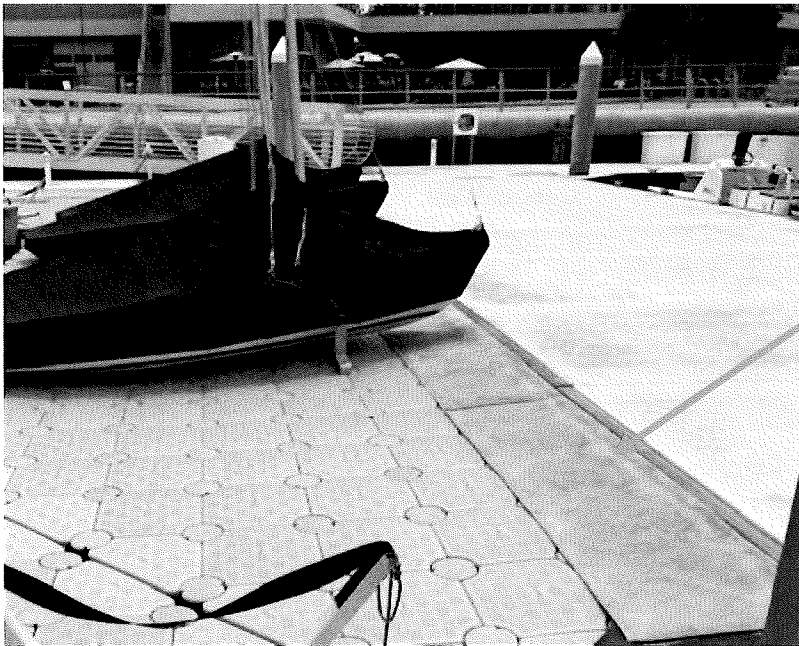

Ramp will fill gap between Main and Floating dock

Confidential

**NEW CANDOCK
FRONT OF CLUB**

CANDOCK WEST COAST LLC
14012 BIRDSEYE COURT
1-530-345-8405
ryan@candockwestcoast.com

Date: 2021-

To : Long Beach Marina

Beige cubes are all other cubes used in this design

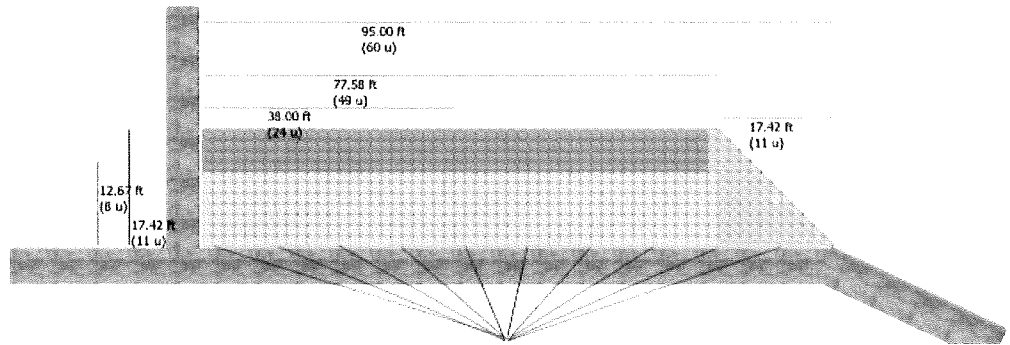

Confidential

Cleat Locations

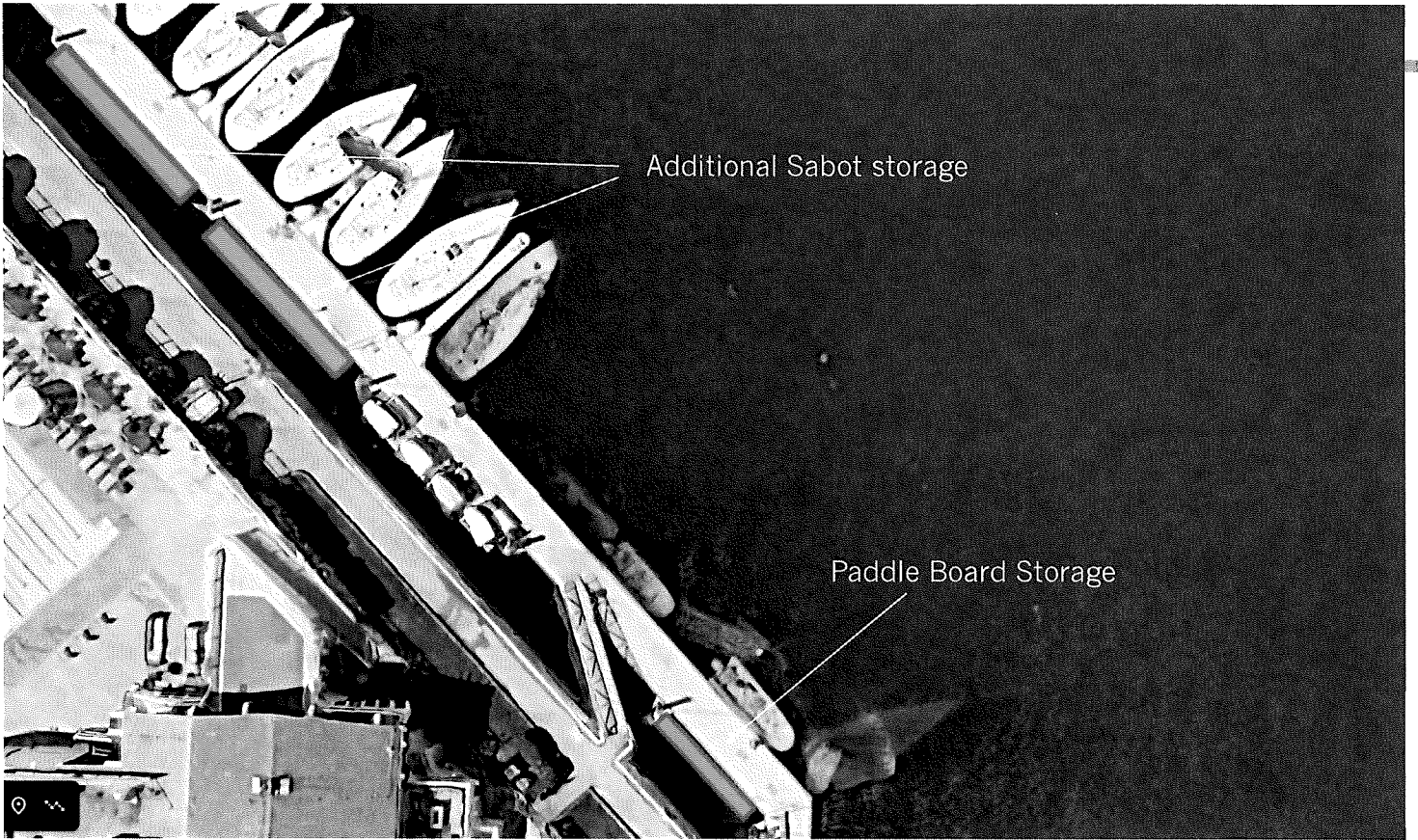

Additional Sabot storage

Paddle Board Storage

SABOT AND PADDLE BOARD

- Sabot Floating Racks 1 & 2 = 1'x 6'x 40'
- Kayak/Paddleboarding Rack 3 = 1'x 6' x 25'

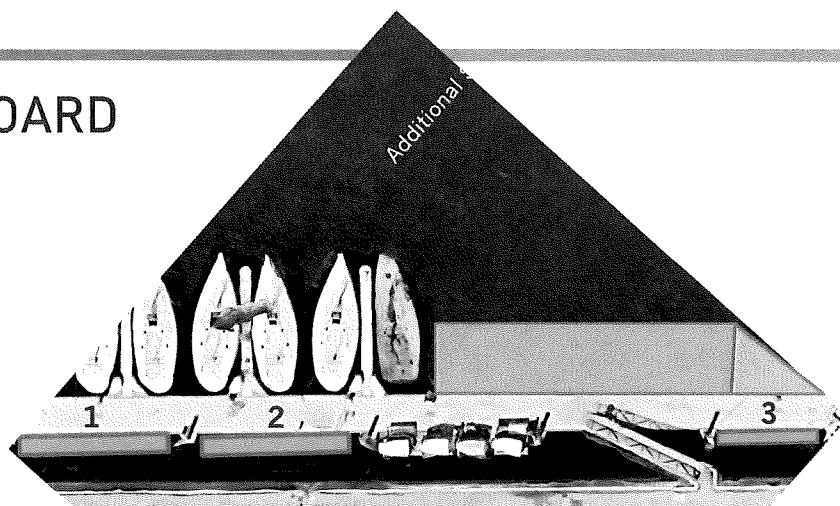

**RECOMMENDATION FOR COACH/UMPIRE BOATS –
USE EXISTING MOUNTING BRACKET LOCATIONS AT SEA BASE WHERE FJ/420S
ARE CURRENTLY LOCATED**

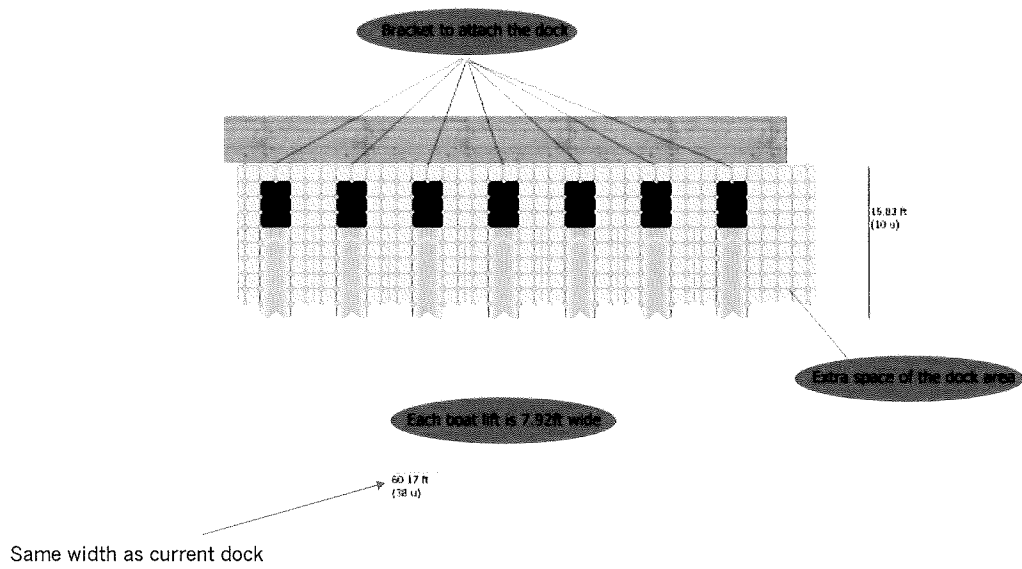

#2 SEA BASE SETUP

- SHORT TERM
 - ONE DESIGN FLEETS – Juniors aged 14+ (approximate) and adults
 - EVENTS/ADVANCED SAILING – 29er, pre-Olympics, higher tech boats
 - Work with Sea Scouts on defining relationship/program/usage.

- LONG TERM –
 - LBYC willing to partner with City of Long Beach, all interested parties to ensure best use of Sea Base prior to and after 2028 Olympic cycle.

- STATUS – HOLDING

-BENEFITS:

1. Safety – right in front of club, close to parents, safety equipment.
2. Efficiency – eliminates 10 minute walk to Sea Base; closer to harbor mouth/bay
3. True “Junior Sailing Hub/Activity Center”
 1. Continuity/Traffic flow from Jobson Room/other meeting areas
 2. Better instruction – Ability to work with different groups in different rooms/areas, use video, white boards, teaching tools in confined space
 3. Better Sabot launching and storage
 4. Collaborate with Forward Planning to maximize clubhouse/facility use
4. Better transition to doublehanded boats:
 1. FJs/Fevas – intermediate and sailing/seamanship courses
 2. 420s – shorter, specific training sessions. Evening practices.
5. Visibility
 1. Talent
 2. Family/Parental participation
 3. Membership in clubhouse views activity – encourages contribution.
6. Maintenance – more convenient
7. Longer Term/Bigger Picture
 1. High School, Collegiate, STEM events in front of club
 2. Sea Base setup for One Design growth for older Juniors along Sailor Development continuum

-OTHER CONSIDERATIONS

- Paddle-boards/small dinghies –
 - Improve – Ease of use – closer to launch area.
- Power Boat Docking
 - Up to 35'
 - Cleats, fenders, optional posts
 - Aisles for Ingress/Egress
- Cruisers – ability to use dock
 - 4th of July, Hosted Events – untie and move
- Dock is configurable

CANDOCK WEST COAST LLC
14012 BIRDSEYE COURT
1-530-345-8405
ryan@candockwestcoast.com

Date: 2021-11-11

To : Long Beach Marina

Beige cubes are all older cubes used in this design

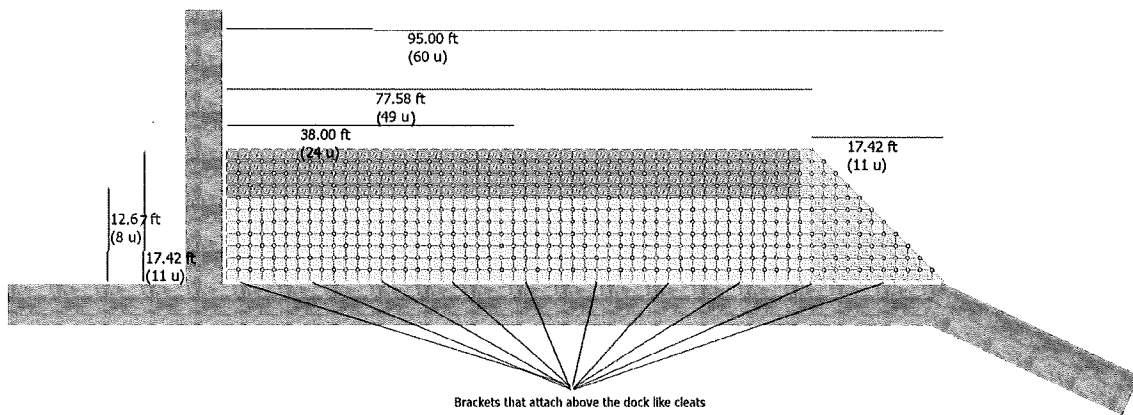

CANDOCK WEST COAST LLC
14012 BIRDSEYE COURT
1-530-345-8405
ryan@candockwestcoast.com

Date: 2021-11-11

To : Chase Young
Long Beach Yacht Club
6201 E. Applian Way
Long Beach, Ca 90803

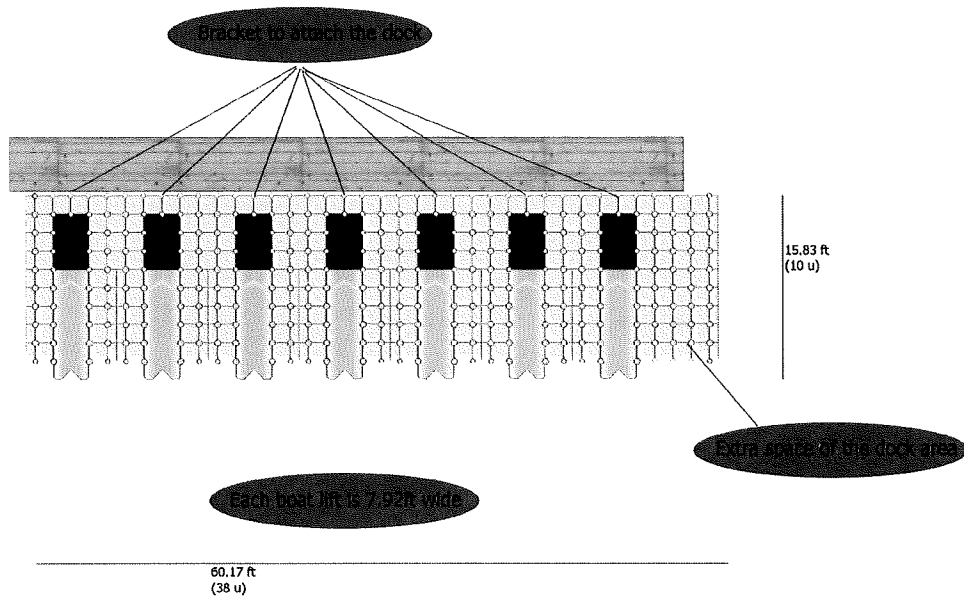

ATTACHMENT D

