

BID NUMBER ITB FS 17-137

TO: CITY OF LONG BEACH  
CITY CLERK  
ATTN: Michelle King  
333 West Ocean Boulevard, Lobby Level  
Long Beach, California 90802



**INVITATION TO BID**

ROLL OFF TRUCKS (4)

CONTRACT NO. 34772

**1. COMPLETE CONTRACT:**

This Invitation to Bid, together with THE NOTICE INVITING BIDS, the entire Bid (including Specifications), or any items(s) thereof, the signature page, Instructions to Bidders, General Conditions, Special Conditions, Bid Section, Addendums, and when required, CONTRACTOR'S BOND shall become the Contract upon its acceptance by the City Manager or designee on behalf of the City of Long Beach, Contractor will be provided with a copy of the executed Contract. All materials or services provided by the Contractor shall comply with the City Charter, and all applicable Federal, State and City Laws.

**2. SERVICES TO BE PROVIDED BY THE CONTRACTOR:**

Contractor shall upon acceptance of this Bid by the City, furnish the goods and services herein specified according to the terms and conditions set forth herein.

**3. AMOUNT TO BE PAID:**

The City shall pay Contractor for the goods or services as described in the section entitled "PAYMENT" in the Instructions to Bidders.

**4. CHOICE OF ALTERNATE PROVISIONS; OPTIONS; NOTIFICATION:**

When alternative provisions are requested, or options are offered, Contractor will be notified as to which provision, or option, is being accepted at the same time that he is notified that he is the successful Bidder.

**5. DECLARATION OF NON-COLLUSION:**

The undersigned certifies or declares under penalty of perjury that this Bid is genuine and not sham or collusive, or made in the interest or on behalf of any person or entity not herein named; that the Bidder has not directly or indirectly induced or solicited any other Bidder to submit a sham bid, or any other person or entity to refrain from bidding, and that the Bidder has not in any manner sought by collusion to secure to himself any advantage over other Bidders.

**BIDDER MUST COMPLETE AND SIGN BELOW:**

(Signature of Corporate Officers or persons authorized to sign bids and contracts on behalf of the Contractor – refer to page 2 Instructions Concerning Signatures.)

EXECUTED AT: WHITTIER CA ON THE 29TH. DAY OF AUGUST, 20 17  
CITY STATE MONTH  
LOS ANGELES TRUCK CENTERS, LLC dba LOS ANGELES

COMPANY NAME: FREIGHTLINER TIN: [REDACTED]  
(FEDERAL TAX IDENTIFICATION NUMBER)

STREET ADDRESS: 2429 S. PECK ROAD CITY: WHITTIER STATE: CA ZIP: 90601

PHONE: (562) 447-1200 FAX: (562) 447-1544

S/ [Signature] (SIGNATURE) PRESIDENT (TITLE)  
James A. Barker (PRINT NAME) cbarker@LAFLR.com (EMAIL ADDRESS)

S/ [Signature] (SIGNATURE) PRESIDENT (TITLE)  
Bradley C FAUVRE (PRINT NAME) bfauvre@LAFLR.com (EMAIL ADDRESS)

ALL SIGNATURES MUST BE NOTARIZED FOR ALL COMPANIES LOCATED OUTSIDE THE STATE OF CALIFORNIA.  
NO OUT-OF-STATE BID WILL BE CONSIDERED UNLESS A NOTARIAL ACKNOWLEDGMENT IS ATTACHED.  
NOTARIES ARE NOT REQUIRED FOR CALIFORNIA BIDDERS.

IN WITNESS WHEREOF the City of Long Beach has caused this contract to be executed as required by law as of the date stated below.

THE CITY OF LONG BEACH BY [Signature] Director of Financial Management  
10/26/17 Date

APPROVED AS TO FORM October 26, 2017  
CHARLES PARKIN CITY ATTORNEY  
[Signature] Deputy

**BID NUMBER ITB FS 17-137**

The City of Long Beach is committed to provide maximum opportunities for Disadvantaged, Minority, Women and Long Beach Business Enterprises (DBEs, MBEs, WBEs and Local) to compete successfully in supplying our needs for products and services.

**The following information is submitted regarding the Bidder:**

Legal Form of Bidder:

- Corporation  State of \_\_\_\_\_  
Partnership  State of \_\_\_\_\_  
General  Limited   
Joint Venture   
Individual  DBA \_\_\_\_\_  
Limited Liability Company  State of CA.

Composition of Ownership (more than 51% of ownership of the organization):

**OPTIONAL**

Ethnic (Check one):

- Black  Asian  Other Non-white  
 Hispanic  American Indian  Caucasian

Non-ethnic Factors of Ownership (check all that apply):

- Male  Yes - Physically Challenged  Under 65  
 Female  No - Physically Challenged  Over 65

Is the firm certified as a Disadvantaged Business:  Yes  No

Has firm previously been certified as a minority-owned and/or woman-owned business enterprise by any other agency?

- Yes  No

Name of certifying agency: \_\_\_\_\_

**INSTRUCTIONS CONCERNING SIGNATURES**

Please use the proper notary form, which applies to your type of organization on all Bid documents, attachments and bonds requiring a signature by officers of your company.

**NOTE: FAILURE TO COMPLY MAY RESULT IN DISQUALIFICATION OF YOUR BID.**

**INDIVIDUAL (Doing Business As)**

- a. The only acceptable signature is the owner of the company. (Only one signature is required.)  
b. The owner's signature must be notarized if the company is located outside of the state of California.

**PARTNERSHIP**

- a. The only acceptable signature(s) is/are that of the general partner or partners.  
b. Signature(s) must be notarized if the partnership is located outside of the state of California.

**CORPORATION**

- a. Two (2) officers of the corporation must sign.  
b. Each signature must be notarized if the corporation is located outside of the state of California.

**OR**

- a. The signature of one officer or the signature of person other than an officer is acceptable if the Bid is accompanied by a certified corporate resolution granting authority to said person to execute contracts on behalf of the corporation.  
b. Signature(s) must be notarized if the corporation is located outside of the state of California.

**LIMITED LIABILITY COMPANY**

- a. The signature on the Bid must be a member or, if the Articles provide for a manager, must be the manager. (Only one signature is required.)  
b. Signature must be notarized if the company is located outside of the state of California.

**THIS INFORMATION IS AVAILABLE IN AN ALTERNATIVE FORMAT BY CONTACTING 562-570-6200.**

**BID NUMBER ITB FS 17-137**

The City of Long Beach is committed to provide maximum opportunities for Disadvantaged, Minority, Women and Long Beach Business Enterprises (DBEs, MBEs, WBEs and Local) to compete successfully in supplying our needs for products and services.

**The following information is submitted regarding the Bidder:**

Legal Form of Bidder:

- Corporation  State of \_\_\_\_\_
- Partnership  State of \_\_\_\_\_
  - General  Limited
- Joint Venture
- Individual  DBA \_\_\_\_\_
- Limited Liability Company  State of CA.

Composition of Ownership (more than 51% of ownership of the organization):

**OPTIONAL**

Ethnic (Check one):

- Black  Asian  Other Non-white
- Hispanic  American Indian  Caucasian

Non-ethnic Factors of Ownership (check all that apply):

- Male  Yes - Physically Challenged  Under 65
- Female  No - Physically Challenged  Over 65

Is the firm certified as a Disadvantaged Business:  Yes  No

Has firm previously been certified as a minority-owned and/or woman-owned business enterprise by any other agency?

- Yes  No

Name of certifying agency: \_\_\_\_\_

**INSTRUCTIONS CONCERNING SIGNATURES**

Please use the proper notary form, which applies to your type of organization on all Bid documents, attachments and bonds requiring a signature by officers of your company.

**NOTE: FAILURE TO COMPLY MAY RESULT IN DISQUALIFICATION OF YOUR BID.**

**INDIVIDUAL (Doing Business As)**

- a. The only acceptable signature is the owner of the company. (Only one signature is required.)
- b. The owner's signature must be notarized if the company is located outside of the state of California.

**PARTNERSHIP**

- a. The only acceptable signature(s) is/are that of the general partner or partners.
- b. Signature(s) must be notarized if the partnership is located outside of the state of California.

**CORPORATION**

- a. Two (2) officers of the corporation must sign.
- b. Each signature must be notarized if the corporation is located outside of the state of California.

**OR**

- a. The signature of one officer or the signature of person other than an officer is acceptable if the Bid is accompanied by a certified corporate resolution granting authority to said person to execute contracts on behalf of the corporation.
- b. Signature(s) must be notarized if the corporation is located outside of the state of California.

**LIMITED LIABILITY COMPANY**

- a. The signature on the Bid must be a member or, if the Articles provide for a manager, must be the manager. (Only one signature is required.)
- b. Signature must be notarized if the company is located outside of the state of California.

**THIS INFORMATION IS AVAILABLE IN AN ALTERNATIVE FORMAT BY CONTACTING 562-570-6200.**

### ACKNOWLEDGMENT

A notary public or other officer completing this certificate verifies only the identity of the individual who signed the document to which this certificate is attached, and not the truthfulness, accuracy, or validity of that document.

State of California  
County of \_\_\_\_\_)

On \_\_\_\_\_ before me, \_\_\_\_\_  
(insert name and title of the officer)

personally appeared \_\_\_\_\_,  
who proved to me on the basis of satisfactory evidence to be the person(s) whose name(s) is/are subscribed to the within instrument and acknowledged to me that he/she/they executed the same in his/her/their authorized capacity(ies), and that by his/her/their signature(s) on the instrument the person(s), or the entity upon behalf of which the person(s) acted, executed the instrument.

I certify under PENALTY OF PERJURY under the laws of the State of California that the foregoing paragraph is true and correct.

WITNESS my hand and official seal.

Signature \_\_\_\_\_ (Seal)

#### OPTIONAL

Though the data below is not required by law, it may prove valuable to persons relying on the document and could prevent fraudulent reattachment of this form.

#### CAPACITY CLAIMED BY SIGNER

- INDIVIDUAL
- CORPORATE OFFICER
- \_\_\_\_\_ TITLE(S)
- PARTNER(S)       LIMITED
- GENERAL
- ATTORNEY-IN-FACT
- TRUSTEE(S)
- GUARDIAN/CONSERVATOR
- OTHER:

#### DESCRIPTION OF ATTACHED DOCUMENT

\_\_\_\_\_ TITLE OR TYPE OF DOCUMENT

\_\_\_\_\_ NUMBER OF PAGES

\_\_\_\_\_ DATE OF DOCUMENT

**SIGNER IS REPRESENTING:**  
NAME OF PERSON(S) OR ENTITY(IES):

\_\_\_\_\_ SIGNER(S) OTHER THAN NAMED ABOVE

**INSTRUCTIONS TO BIDDERS**

**1. PREPARATION OF BID:**

The preparation of the Bid, including visits to the Site prior to submittal of the Bid, shall be at the expense of Bidder. All prices and notations must be typewritten or written in ink. Any markings in pencil shall not form part of the Bid and shall be disregarded by the City. Any changes or corrections in the Bid must be initialed in ink by the person signing the Bid. Bidder shall state brand name or make of each item bid. If not bidding on item as described, the manufacturer's name and catalog number of the substitute must be given. Bidder shall also attach specifications and furnish other data to establish the suitability of the substitute. Bidder shall quote separately on each item. Bidder shall quote his lowest price and best delivery date as no changes are permitted after the bid opening. Cash discounts offered for payment within fourteen (14) days or less will not be considered when evaluating bids. No telephonic, telegraphic or fax Bids are acceptable.

**NOTE: ALL PAGES OF THE INVITATION TO BID MUST BE RETURNED.**

**2. EXAMINATION OF BID:**

Bidder is responsible for examining the Invitation to Bid and submitting its Bid complete and in conformance with these instructions.

**3. CONDITIONS OF WORK:**

Bidder shall carefully examine the Site to become fully informed regarding all existing and expected conditions and matters, which could affect performance, cost or time of the Work.

**4. DISCREPANCIES IN BID DOCUMENTS:**

If Bidder finds discrepancies in or omissions from the Invitation to Bid, if the intent of the Invitation is not clear, or if provisions of the Specifications restrict Bidder from bidding, he may request in writing that the deficiency(s) be modified. Such request must be received by the City Purchasing Agent at least five (5) working days before bid opening date. Bidders will be notified by Addendum of any approved changes in the Invitation to Bid.

**5. ORAL STATEMENTS:**

The City of Long Beach shall not be bound by oral statements made by any employee or agent concerning this Invitation to Bid. If Bidder requires specific information, Bidder must request it in writing and obtain a reply in writing from the City.

**6. BRAND NAMES AND SPECIFICATIONS:**

The detailed specifications and/or brand names stated are descriptive only and indicate quality, design and construction of items required. **Offers will be considered to supply articles substantially the same as those described herein but with minor variations. Bidders must describe variations in the Bid.** Substitute items must be equal in quality, utility and performance. **The phrase "or approved equal" throughout the specifications means that the City in its sole and absolute discretion shall make the final determination whether or not the substitute items are equal.**

**7. AWARD:**

Bid shall be subject to acceptance by the City for a period of three (3) months unless a lesser period is prescribed in the quotation by Bidder. The City reserves the right to award all items to one Bidder, or to award separate items or groups of items to various Bidders, or to increase or decrease the quantities of any item. Bidder may submit alternate prices or name a lump sum or discount conditional on two or more items being awarded to him.

The City's purchases of goods and services are based on the City's actual needs and requirements. The City is obligated under this contract/purchase order to purchase and pay for only those goods and services that the City needs and requires, and that the City actually orders and receives. Any dollar amount identified as a "not to exceed:" amount in any City document is not a guaranteed payment amount to any contractor or service provider. Furthermore, the City may determine that its needs and requirements may be met by City labor or by a second contractor or service provider, even after an award is made to one contractor or service provider. An award is not a promise or guarantee of exclusivity.

Bidders are cautioned that comments and statements, whether oral or written, made by City employees regarding the validity of Bids, the waiver of deviations from Specifications, the possibility or probability of an award being made to a particular Bidder, and other similar matters are NOT binding on the City. Bidders should not order materials, obtain financing or take other actions based on such comments and statements. Only authorization of a Contract by the City Council or issuance of a Purchase Order is conclusive and binding on the City with respect to this Bid and its resulting Contract or Purchase Order. However, prior to authorization by the City Council or issuance of the Purchase Order, Bidders may rely on: (1) approval of an "equal" or "substitute" item which will be issued in writing, and (2) written notice of intent to award by the City Council, which is often issued prior to the authorization by the City Council so that a Bidder can order materials that have a long lead time.

**8. PAYMENT:**

Payment terms are NET/30 unless Bidder otherwise quotes. All Cash Discounts shall be taken and computed from the date of delivery or completion and acceptance of the material, or from date of receipt of invoice, whichever occurs last. Invoices must be submitted as specified at the time of shipping authorization. Partial payments may be made by the City on delivery & acceptance of goods and on receipt of goods and on receipt of Contractor's invoice.

In the event the Contract to be awarded hereunder, including specifications and other documents incorporated therein by reference, provides for the withholding of moneys by the City to ensure performance of such Contract, Contractor may deposit with the City, as a substitute for said withheld moneys, securities listed in Section 16430 of the California Government Code or bank or savings and loan certificates of deposit, or both, equivalent to the amount withheld, provided Contractor requests permission to make such substitution and bears all expenses in connection therewith.

**9. SAFETY APPROVAL:**

Where required by City Regulations, any items delivered must carry Underwriters Laboratories Approval or City of Long Beach City Safety Officer approval. Failure to so comply will be cause to reject Bid. Also, any equipment must conform with the Safety Orders of the California Division of Industrial Safety and OSHA regulations.

**10. BUSINESS LICENSE:**

The Long Beach Municipal Code (LBMC) requires all businesses operating in the City of Long Beach to pay a business license tax. In some cases the City may require a regulatory permit and/or evidence of a State or Federal license. Prior to issuing a business license, certain business types will require the business license application and/or business location to be reviewed by the Development Services, Fire, Health, and/or Police Departments. For more information, go to [www.longbeach.gov/finance/business\\_license](http://www.longbeach.gov/finance/business_license).

**INSTRUCTIONS TO BIDDERS**

**11. PUBLIC WORK AND PREVAILING WAGES:**

The Contractor to whom the contract is awarded, along with its subcontractors, shall pay not less than the general prevailing rate of per diem, holiday and overtime wages established by the Department of Industrial Relations (DIR) of the State of California for the locality in which the public work is to be performed for each craft, classification or type of worker needed to execute the contract. Refer to the California DIR's website, <http://www.dir.ca.gov/dlsr> for such prevailing wages and additional information.

The Director of Public Works of the City by and on behalf of the City Council has obtained from the Director of the Department of Industrial Relations of the State of California the general prevailing rate of per diem wages and the general prevailing rate of holiday and overtime work in the locality in which the public work is to be performed for each craft, classifications or type of workers needed to execute the Contract, and the same is on file with the City Engineer, 9<sup>th</sup> floor, City Hall, 333 W. Ocean Boulevard, Long Beach, California 90802. It shall be mandatory upon the Contractor to whom the Contract is awarded, and his Subcontractors to pay not less than the said prevailing rate of wages to all workers employed by Contractor or said Subcontractors in the execution of the Contract.

**12. RIGHT TO REJECT:**

The City reserves the right to reject at any time any or all Bids, or parts thereof, and to waive any variances, technicalities and informalities which do not impair the quality, utility, durability or performance of the items.

**13. SAMPLES:**

Samples of items when requested or required must be furnished to the City free of expense to the City and, if not destroyed by tests, will upon request be returned at Bidder's expense.

**14. PRICES:**

Prices shall be in accordance with those extended to other governmental agencies. In case of error in extension of prices, unit price will govern. All prices must be firm for the Contract term unless the City specifically provides for adjustment.

**15. CITY'S POLICY FOR MINORITY AND WOMEN-OWNED BUSINESSES:**

The City of Long Beach is committed to providing maximum opportunities for Disadvantaged, Minority, Women and Long Beach Business Enterprises (DBEs, MBEs, WBEs and Local) to compete successfully in supplying our needs for products and services.

**SUBCONTRACTORS**

To assist the City in maintaining records of its Minority and Women Outreach Program, Bidder is requested to provide the following information. Answers are optional, and failure to answer will not disqualify Bid. If additional space is required, Bidder shall attach a separate sheet.

The following Minority- or Woman-owned subcontractors are to be utilized to provide equipment, material, supplies and/or services for this Contract requirement:

Company Name: \_\_\_\_\_

Address: \_\_\_\_\_

Commodity/Service Provided: \_\_\_\_\_

Circle appropriate designation: MBE WBE

Ethnic Factors of Ownership: (more than 51%)  
Black ( ) American Indian ( )  
Hispanic ( ) Other Non-white ( )  
Asian ( ) Caucasian ( )

Certified by: \_\_\_\_\_

Valid thru: \_\_\_\_\_

Dollar value of participation: \$ \_\_\_\_\_

**16. BID SUBMITTAL AND WITHDRAWAL OF BIDS:**

Each Bid must be delivered to the location and received on or before the due date and time stated herein. Bids will not be accepted after the date and time stated herein. Bids may be withdrawn without prejudice providing the written request is received by the City Clerk no later than the time set for opening Bids. Withdrawals will be returned to Bidder unopened.

SUBMIT TO:  
CITY OF LONG BEACH  
CITY CLERK – ATTN: MICHELLE KING  
333 W OCEAN BLVD/LOBBY LEVEL  
LONG BEACH CA 90802

**BID DUE DATE:** AUGUST 31, 2017

**TIME:** 11:00 am

IF BIDDER HAS ANY QUESTIONS REGARDING THIS INVITATION TO BID PLEASE CONTACT THE FOLLOWING CITY PERSONNEL.

MICHELLE KING (562) 570-6020  
BUYER TELEPHONE NUMBER

**17. BID OPENING PROCEDURES:**

All bids are publicly opened and will be posted on the City's online system at the date and time noted on the Invitation to Bid.

Bid results are posted on the City's online system as soon as they have been reviewed for responsiveness. Bids are awarded to the lowest responsible and responsive bidder meeting the City's specifications. Bid results will not be given out via telephone, City email, or facsimile.

CAUTION: Only the City Council has authority to make an award, and a contract is not in effect until the City Council makes an award and contract documents (including insurance and bonds) are signed, submitted and approved.

Bid protest procedures may be obtained from the Buyer. Protests must be submitted within five (5) business days following the electronic notification of intent to award.

**18. INTER-AGENCY PARTICIPATION:**

IF OTHER AGENCIES EXPRESS AN INTEREST IN PARTICIPATING IN THIS BID, WOULD YOU SUPPLY THE SAME ITEMS.

YES X NO \_\_\_\_\_

(If yes, any agency electing to participate in this Bid will order its own requirements without regard to the City of Long Beach. The City of Long Beach assumes no liability or payment guarantee on any units sold to participating agencies.)

**19. AMERICANS WITH DISABILITIES ACT:**

**INSTRUCTIONS TO BIDDERS**

Contractor shall have and be allocated the sole responsibility to comply with the Americans with Disabilities Act of 1990 ("ADA") with respect to performance hereunder and contractor shall defend, indemnify and hold the City, its officials and employees harmless from and against any and all claims of failure to comply with or violation of the ADA as said claim relates to this Contract.

**20. EQUAL BENEFITS ORDINANCE:**

Bidders/Proposers are advised that any contract awarded pursuant to this procurement process shall be subject to the applicable provisions of Long Beach Municipal Code section 2.73 et seq., the Equal Benefits Ordinance. Bidders/Proposers shall refer to Attachment/Appendix for further information regarding the requirements of the Ordinance.

All Bidders/Proposers shall complete and return, with their bid/proposal, the Equal Benefits Ordinance Compliance form contained in the Attachment/Appendix. Unless otherwise specified in this procurement package, Bidders/Proposers do not need to submit supporting documentation verifying with their bids/proposals. However, supporting documentation verifying that the benefits are provided equally shall be required if the Bidder/Proposer that is selected for award of a contract.

**CONTRACT – GENERAL CONDITIONS**

1. Acceptance of the offer contained in this Contract is expressly limited to the terms and conditions of such offer as herein stated.
2. No charges for taxes, transportation, boxing, packaging, crating or returnable containers will be allowed and paid by the City unless separately stated hereon. All sales, use, excise or similar taxes to be paid by the City must be itemized separately hereon and on invoices. The City is exempt from payment of Federal Excise Tax under Certificate No. 95-73 0502K and none shall be charged to the City.
3. The City's obligation to pay the sum herein stated for any one fiscal year shall be contingent upon the City Council of the City appropriating the necessary funds for such payment by the City in each fiscal year during the term of this Contract. For the purposes of this section a fiscal year commences on October 1 of the year and continues through September 30 of the following year. In the event that the City Council of the City fails to appropriate the necessary funds for any fiscal year, then, and in that event, the Contract will terminate at no additional cost or obligation to the City.
4. Contractor shall deliver the materials, equipment, supplies or services, or cause the work to be performed, within the time and in the manner specified in the Contract. Times and dates stated herein are of the essence. If at any time Contractor has reason to believe that deliveries will not be made as scheduled, written notice setting forth the cause of the anticipated delay shall be given immediately to the City. Deliveries must be prepaid. C.O.D. shipments will not be accepted.
5. The City reserves the right at any time to make changes in drawings and specifications, in methods of shipment and packaging and in place of delivery as to any articles covered by this Contract. In such event there will be made an equitable adjustment in price and time of performance mutually satisfactory to Contractor and the City; but any claim by Contractor for such an adjustment must be made within thirty (30) days of such change.
6. Contractor warrants that the goods, machinery or equipment delivered or the work performed hereunder shall conform to the specifications, drawings, samples or other description specified by the City and shall be fit and sufficient for the purpose intended, merchantable, of good material and workmanship, in good working order and free from defect or faulty workmanship for a period of ninety (90) days. When defective goods, machinery, or equipment or faulty workmanship is discovered which requires repair or replacement pursuant to this warranty, Contractor shall provide all labor, materials, parts and equipment to correct such defect at no expense to the City.
7. Contractor shall indemnify, protect and hold harmless City, its Boards, Commissions, and their officials, employees and agents ("Indemnified Parties"), from and against any and all liability, claims, demands, damage, loss, obligations, causes of action, proceedings, awards, fines, judgments, penalties, costs and expenses, including attorneys' fees, court costs, expert and witness fees, and other costs and fees of litigation, arising or alleged to have arisen, in whole or in part, out of or in connection with (1) Contractor's breach or failure to comply with any of its obligations contained in this Contract, including any obligations arising from the Contractor's compliance with or failure to comply with applicable laws, including all applicable federal and state labor requirements including, without limitation, the requirements of California Labor Code section 1770 et seq. or (2) negligent or willful acts, errors, omissions or misrepresentations committed by Contractor, its officers, employees, agents, subcontractors, or anyone under Contractor's control, in the performance of work or services under this Contract (collectively "Claims" or individually "Claim").

In addition to Contractor's duty to indemnify, Contractor shall have a separate and wholly independent duty to defend Indemnified Parties at Contractor's expense by legal counsel approved by City, from and against all Claims, and shall continue this defense until the Claims are resolved, whether by settlement, judgment or otherwise. No finding or judgment of negligence, fault, breach, or the like on the part of Contractor shall be required for the duty to defend to arise. City shall notify Contractor of any Claim, shall tender the defense of the Claim to Contractor, and shall assist Contractor, as may be reasonably requested, in the defense.

If a court of competent jurisdiction determines that a Claim was caused by the sole negligence or willful misconduct of Indemnified Parties, Contractor's costs of defense and indemnity shall be (1) reimbursed in full if the court determines sole negligence by the Indemnified Parties, or (2) reduced by the percentage of willful misconduct attributed by the court to the Indemnified Parties.

If the Contractor elects to use subcontractors, Contractor agrees to require its subcontractors to indemnify Indemnified Parties and to provide insurance coverage to the same extent as Contractor. The provisions of this Section shall survive the expiration or termination of this Contract.

8. The City reserves the right to terminate this Contract at any time in whole or in part even though Contractor is not in default hereunder. In such event there will be made an equitable adjustment of the terms that is mutually satisfactory to the City and Contractor. Upon receipt of any notice of such termination, Contractor shall, unless such notice otherwise directs, immediately discontinue all work on the Contract and deliver, if and as directed, to the City all completed and partially completed articles, work in process and materials purchased or acquired for performance of the Contract. The provisions of this section shall not limit or affect the right of the City to terminate this Contract immediately upon written notice of breach.



**CONTRACT – GENERAL CONDITIONS**

9. The City reserves the right to cancel this Contract or any part thereof and reject delivery of goods if delivery is not undertaken and completed when specified and in accordance with specifications. Contractor shall be charged for any direct losses, but not any consequential damages, sustained by the City by reason of such delay or failure, excepting losses caused by a delay for reasons beyond Contractor's reasonable control. Direct losses shall include any costs to the city in excess of the Contract price of obtaining goods from other sources similar to those cancelled or rejected hereunder.
10. The City shall pay to Contractor the price(s) specified in the Contract on delivery of the materials, equipment, supplies or services and acceptance thereof by the City Manager or his designee, or upon completion of the work to be performed and accepted thereof, as specified in the Contract. Defective articles or articles not in accordance with the City's specifications shall be held for Contractor's instructions at Contractor's risk, and if Contractor so directs will be returned at Contractor's expense.
11. No return or exchange of material, equipment or supplies shall be permitted without written approval of the City Purchasing Agent.
12. All royalties for patents, or changes for the use of patents, which may be involved in any article to be furnished under this Contract shall be included in the Contract price.
13. In cases where a price subject to escalation has been agreed upon, the price escalation shall be shown as a separate item on the invoice. Unless an escalator clause has been shown as a specific part of this Contract Contractor shall not be entitled to reimbursement for costs incurred due to escalation.
14. All materials, supplies and equipment provided under this Contract shall be in full compliance with the Safety Orders and Regulations of the Division of Industrial Safety of the State of California, Title 8, California Code of Regulations (CAL/OSHA) and all applicable OSHA regulations as well as all other applicable California Code of Regulations. Contractor shall indemnify and hold the City, its officials, and employees harmless for, of and from any and all loss, including but not limited to fines, penalties and corrective measures, the City may sustain by reason of Contractor's failure to comply with said laws, rules and regulations in connection with the performance of this Contract.
15. Contractor shall keep confidential and not disclose to others or use in any way to the detriment of the City confidential business or technical information that the City may disclose in conjunction with this Contract or Contractor may learn as a result of performing this Contract.
16. This Contract shall not be assigned in whole or in part, nor any duties delegated without the City's prior written approval.
17. The remedies herein reserved shall be cumulative and additional to any other remedies at law or in equity. The waiver of any breach of this Contract shall not be held to be a waiver of any other or subsequent breach. The City's failure to object to provisions contained in any communication from Contractor shall not be deemed an acceptance of such provisions or a waiver of the provisions of this Contract.
18. This Contract shall not be amended or modified, except by written agreement signed by the parties and expressly referring to this Contract.
19. Contractor shall indemnify, hold harmless and defend the City, its officials and employees from any damage, claim, loss, cost, liability, cause of action or expense, including reasonable attorney's fees, whether or not reduced to judgment, arising from any infringement or claimed infringement of any patent, trademark or copyright, or misappropriation of confidential information or trade secrets of any third party and based on the manufacture, sale or use of goods, machinery or equipment supplied hereunder.
20. Contractor shall furnish further itemization and breakdown of the Contract price when requested by the City.
21. Contractor, in the performance of any work or the furnishing of any labor under this Contract, shall be considered as an independent contractor. Contractor, his agents and employees shall not be considered as employees of the City.
22. Contractor and subcontractor(s) shall not discriminate against any person in the performance of this Contract and shall comply with applicable federal, state and city equal employment opportunity laws, ordinances, rules and regulations. Contractor and subcontractor(s) shall not discriminate against any employee or applicant for employment or against any subcontractor on the basis of race, color, religion, national origin, sex, sexual orientation, AIDS, HIV status, age, disability, or handicap, subject to federal and state laws, rules and regulations.
23. Contractor shall comply with all applicable federal, state and local laws pertaining to the subject matter hereof.
24. Contractor shall submit samples of all documents that Contractor may require the City to execute to complete this transaction. By accepting these samples as part of the bid or by awarding the Contract to a Contractor who has submitted said samples, the City

**CONTRACT – GENERAL CONDITIONS**

does not agree to the terms stated in said samples. This Invitation to Bid and Contractor's bid shall take priority over said samples and this Invitation and Contractor's bid shall become the Contract between the City and the Contractor.

25. All quantities stated herein are only ESTIMATES. The City reserves the right to increase or decrease these estimated quantities based on its actual needs and funds available.
26. The City reserves the right to exercise, at its option, an increase in expenditures by ten (10) percent annually, but the City does not guarantee such an increase.
27. Contractor shall cooperate with the City in all matters relating to taxation and the collection of taxes, particularly with respect to the self-accrual of use tax. Contractor shall cooperate as follows: (i) for all leases and purchases of materials, equipment, supplies or other tangible personal property totaling over \$100,000 shipped from outside California, a qualified Contractor shall complete and submit to the appropriate governmental entity the form in Appendix "A" attached hereto; and (ii) for construction contracts and subcontracts totaling \$5,000,000 or more, Contractor shall obtain a sub-permit from the California Board of Equalization for the Work site. "Qualified" means that the Contractor purchased at least \$500,000 in tangible personal property that was subject to sales or use tax in the previous calendar year.

In completing the form and obtaining the permit(s), Contractor shall use the address of the Work site as its business address and may use any address for its mailing address. Copies of the form and permit(s) shall also be delivered to the Purchasing Agent. The form must be submitted and the permit(s) obtained as soon as Contractor receives a notice of award. Contractor shall not order any materials or equipment over \$100,000 from vendors outside California until the form is submitted and the permit(s) obtained and, if Contractor does so, it shall be a material breach of the Agreement. In addition, Contractor shall make all purchases from its Long Beach sales office and the Long Beach sales office of its vendors if those vendors have a Long Beach office and all purchases made by Contractor under this Agreement which are subject to use tax of \$500,000 or more shall be allocated to the City of Long Beach. Contractor shall require the same form and permit(s) from its subcontractors.

Contractor shall not be entitled to and by signing this Contract waives any claim or damages for delay against City if Contractor does not timely submit these forms to the appropriate governmental entity. Contractor may contact Julissa Jose-Murray at 562-570-6869 for assistance with the form.

28. The California Integrated Waste Management Act (Public Resources Code, Sec. 40000 et seq.) requires governmental entities to achieve fifty (50) percent diversion of waste. In conjunction with the City's Integrated Resources Bureau, the City is currently developing an Environmentally Preferable Product (EPP) procurement plan. These guidelines enable the City Purchasing Agent to greatly expand procurement programs by moving beyond a singular consideration of "recycled-content". EPP procurement facilitates the purchase of products that qualify within a broad range of "environmentally preferable" criteria, such as: minimal packaging; energy savings; non-toxic; manufactured from sustainably-harvested materials. Contractor shall monitor products that fall within the EPP guidelines and document all criteria that qualifies the product as an EPP. Documentation from the manufacturer will be acceptable and may be required during the term of the Contract.
29. **NOTICE TO BIDDERS REGARDING THE PUBLIC RECORDS ACT:**  
Responses to this Invitation to Bid become the exclusive property of the City of Long Beach. All Bids submitted in response to this Invitation to Bid are a matter of public record and shall be regarded as public records. Exceptions will be only those elements in each Bid that are defined by the Bidder as business or trade secrets and are marked as "Trade Secrets", "Confidential" or "Proprietary".  
  
The City shall not be liable or responsible in any way for disclosure of any records not marked as "Trade Secrets", "Confidential" or "Proprietary". The City shall not be liable or responsible in any way for disclosure of any records so marked if disclosure is deemed to be required by law or by a court order.
30. **NOTE: FAILURE TO COMPLY WITH THESE ADDITIONAL CONDITIONS WILL DISQUALIFY A BIDDER. NOTICE OF INTENTION TO APPLY FOR WAIVER OF ALL OR A PORTION OF THESE INSURANCE REQUIREMENTS MUST BE IN COMPLIANCE WITH CITY OF LONG BEACH ADMINISTRATIVE REGULATION 8-27 (AR 8-27). NOTE THAT COMPLIANCE WITH THE CITY'S INDEMNIFICATION IS MANDATORY FOR A RESPONSIVE BIDDER.**

THE FOLLOWING ADDITIONAL CONDITIONS APPLY TO ALL BIDS:

**INSURANCE:** As a condition precedent to the effectiveness of this Contract, Contractor shall procure and maintain at its expense, until completion of performance and acceptance by City, from an insurer admitted (licensed) in the State of California with a current financial responsibility rating of A (Excellent) or better and a current financial size category (FSC) of V (capital surplus and conditional surplus funds of greater than \$10 million) or greater rating as reported by A.M. Best Company or equivalent, unless waived in writing by City's Risk Manager, or non-admitted in the State of California with a current financial responsibility rating of A (Excellent) or better

**CONTRACT – GENERAL CONDITIONS**

and a current financial size category (FSC) of VIII (capital surplus and conditional surplus funds of greater than \$100 million) or greater rating as reported by A.M. Best Company or equivalent, unless waived in writing by City's Risk Manager.

- (a) Commercial general liability insurance or self-insurance equivalent in coverage scope to ISO CG 00 01 10 93 naming **the City of Long Beach, and its boards, officials, employees, and agents** as additional insureds on a form equivalent in coverage scope to ISO CG 20 10 11 85 from and against claims, demands, causes of action, expenses, costs, or liability for injury to or death of persons, or damage to or loss of property arising out activities performed by or on behalf of the Contractor in an amount not less than One Million Dollars (US \$1,000,000) per occurrence and Two Million Dollars (US \$2,000,000) in general aggregate.
- (b) Workers' compensation coverage as required by the Labor Code of the State of California and Employer's liability insurance with minimum limits of One Million Dollars (US \$1,000,000) per accident or occupational illness. The policy shall be endorsed with a waiver of the insurer's right of subrogation against **the City of Long Beach, and its boards, officials, employees, and agents**.
- (c) Automobile liability insurance equivalent in coverage scope to ISO CA 00 01 06 92 in an amount not less than Five Hundred Thousand Dollars (US \$500,000) combined single limit (CSL) per accident for bodily injury and property damage covering Symbol 1 ("all autos").

Any self-insurance program or self-insurance retention must be approved separately in writing by the City's Risk Manager or designate and shall protect the **City of Long Beach, and its boards, officials, employees, and agents** in the same manner and to the same extent as they would have been protected had the policy or policies not contained retention provisions. Each insurance policy shall be endorsed to state that coverage shall not be suspended, voided, or canceled by either party except after thirty (30) days prior written notice to the City of Long Beach, and shall be primary and not contributing to any other insurance or self-insurance maintained by the City of Long Beach.

**Any subcontractors of all tiers which Contractor may use in the performance of this Contract shall be required to maintain insurance in compliance with the provisions of this section. The additional insured endorsement form number applicable to subcontractors with respect to the general liability insurance shall be the ISO CG 20 26 11 85 form or its equivalent.**

Contractor shall deliver to the City of Long Beach certificates of insurance and original endorsements for approval as to sufficiency and form prior to the start of performance hereunder. The certificates and endorsements for each insurance policy shall contain the original signature of a person authorized by that insurer to bind coverage on its behalf. "Claims-made" policies are not acceptable unless the City's Risk Manager determines that "Occurrence" policies are not available in the market for the risk being insured. In a "Claims-made" policy is accepted, it must provide for an extended reporting period of not less than one hundred eighty (180) days. Such insurance as required herein shall not be deemed to limit Contractor's liability relating to performance under this Contract. The City of Long Beach reserves the right to require complete certified copies of all said policies at any time. Any modification or waiver of the insurance requirements herein shall be made only with the approval of the City's Risk Manager. The procuring of insurance shall not be construed as a limitation on liability or as full performance of the indemnification provisions of this Contract.

To the extent more stringent insurance requirements apply in accordance with the City of Long Beach's Administrative Regulation 8-27 (AR 8-27) and its amendments, the currently in-force AR 8-27 regulations and requirements supersede and replace any insurance requirements stated herein.

**INDEMNITY: To the extent allowed by law**, Contractor shall defend, indemnify, and hold harmless the City, its Commissions and Boards, and their officials, employees, and agents from and against any and all demands, claims, causes of action, liability, loss, liens, damage, costs, and expenses (including attorney's fees) arising from or in any way connected or alleged to be connected with Contractor's performance of the performance under the Contract or the work under or related to the Contract and from any act or omission, willful misconduct, or negligence (active or passive) by or alleged to be by Contractor, its employees, agents, or subcontractors either as a sole or contributory cause, sustained by any person or entity (including employees or representatives of City or Contractor). The foregoing shall not apply to claims or causes of action caused by the sole negligence or willful misconduct of the City, its Commissions and Boards, or their officials, employees, or agents.

In addition to Contractor's duty to indemnify, Contractor shall have a separate and wholly independent duty to defend Indemnified Parties at Contractor's expense by legal counsel approved by City, from and against all Claims, and shall continue this defense until the Claims are resolved, whether by settlement, judgment or otherwise. No finding or judgment of negligence, fault, breach, or the like on the part of Contractor shall be required for the duty to defend to arise. City shall notify Contractor of any Claim, shall tender the defense of the Claim to Contractor, and shall assist Contractor, as may be reasonably requested, in the defense.

If a court of competent jurisdiction determines that a Claim was caused by the sole negligence or willful misconduct of Indemnified Parties, Contractor's costs of defense and indemnity shall be (1) reimbursed in full if the court determines sole negligence by the Indemnified Parties, or (2) reduced by the percentage of willful misconduct attributed by the court to the Indemnified Parties. The provisions of this Section shall survive the expiration or termination of this contract.

**CONTRACT – GENERAL CONDITIONS**

THE FOLLOWING ADDITIONAL CONDITIONS APPLY ONLY IN CASES WHERE CONTRACTOR IS TO PERFORM WORK FOR THE CITY OR ON CITY PROPERTY:

Before execution of a Contract, the bidder shall file two surety bonds with the City of Long Beach subject to the approval of the City Engineer and City Attorney. The bonds shall be on forms provided by the City or acceptable to the City Attorney. The Payment Bond (Material and Labor Bond) shall satisfy claims of material suppliers and mechanics and laborers employed by the contractor on the Work. This bond shall be maintained by the contractor in full force and effect until the work is accepted by the City of Long Beach and until all claims for materials and labor are paid, and shall otherwise comply with the Civil Code. The Performance Bond shall guarantee faithful performance of all work within the time and manner prescribed, free from original or developed defects. This bond shall remain in effect as prescribed within the Contract, until the end of all warranty periods.

If at any time during the progress of the Work, Contractor shall allow any indebtedness to accrue for labor, equipment or materials, or which may become a claim against the City, Contractor shall immediately upon request from the City pay such claim or indebtedness or cause such lien to be dissolved and discharged by giving a bond or otherwise and, in case of his failure so to do, the City may withhold any money due Contractor until such claim or indebtedness is paid or may apply such money toward the discharge thereof; or in such event the City may, at its option, declare this Contract to be terminated, take possession and control of the Work, and complete the same or cause the same to be completed according to the specifications. Contractor shall pay to the City the difference between the Contract price and the actual cost to the City in completing or causing the Work to be completed.

Contractor shall carry on the Work at its own risk until the same is fully completed and accepted and shall, in case of any accident, destruction or injury to the Work or materials before its final completion and acceptance, repair or replace the Work or materials so injured, damaged and destroyed, at his own expense and to the satisfaction of the City. When materials and equipment are furnished by others for installation or erection by Contractor, Contractor shall receive, unload, store and handle same at the Site and become responsible therefore as though such materials and equipment were being furnished by Contractor under the Contract.

Contractor shall list the name and location of the place of business of each Subcontractor who will perform work, labor or services for Contractor, or who specially fabricates and installs a portion of the Work or improvement in an amount in excess of one-half of one percent of Contractor's total contract cost. The Subcontractor list shall be submitted with Contractor's Bid.

## **PROJECT OVERVIEW**

The City of Long Beach (City), Fleet Services Bureau is seeking bids from qualified vendors for the purchase of four (4) heavy duty CNG powered roll off truck(s).

See **Appendix A** for detailed specifications.

## **BID TIMELINE** – All times are Pacific Time

Bid release date:	August 9, 2017
Questions due:	August 16, 2017 by 11:00 am
Response from City to bidder:	August 23 by 2:00 pm
Bid due date:	August 31, 2017 by 11:00 am

## **BID SUBMISSION INSTRUCTIONS:**

It is recommended that bidders visit the City's website [www.longbeach.gov/purchasing](http://www.longbeach.gov/purchasing) on a regular basis for any addenda to the bid.

The following documents shall be submitted as general attachments. Bidders that do not include these items will be deemed non-responsive and their bids will be rejected.

- Signed Bid Cover Page
- California All Purpose Acknowledgment, Notarized (if applicable)
- Debarment Certification Form (Attachment A)
- Reference List (Attachment B)
- W-9 Form (Attachment C)
- Equal Benefits Ordinance (EBO) (Attachment D)
- Insurance Requirement (Attachment E)

## **METHOD OF SUBMISSION:**

Electronic Bids shall be submitted via the City's secure online bidding system. All required sections of the Bid must be submitted via the website. Bidder is solely responsible for "on time" submission of their electronic bid. The Bid Management System will not accept late bids and no exceptions shall be made. Bidders will receive an e-bid confirmation number with a time stamp from the Bid Management System indicating that their bid was submitted successfully. The City will only receive those bids that were transmitted successfully.

When bids on certain items are labeled "optional", bidders shall indicate "no bid" or "N/A" in the space provided for an item for which no bid is being offered.

Bid cover page shall be signed in ink and included with the electronic bid submission as a general attachment. Digital and stamped signatures shall not be accepted.

Pricing shall be submitted electronically on the Line Items tab and all pages of the bid document shall be uploaded as a general attachment.

Submit bid online at: <http://www.planetbids.com/portal/portal.cfm?CompanyID=15810>

**In addition to the electronic submission, bidders shall submit the following original document(s) with wet signature(s) in a sealed envelope to the address shown below:**

1. Original bid cover page
2. A notarized California All-Purpose Acknowledgement Form (for all companies located outside the State of California)

City of Long Beach  
C/O City Clerk  
Attn: Michelle King  
333 West Ocean Boulevard, Lobby Level  
Long Beach, CA 90802

Documents shall be clearly labeled in a sealed envelope or box as follows:

#### **ITB FS 17-137 ROLL OFF TRUCKS (4)**

**Electronic Bids and required hard copy forms must be received by 11:00 AM Pacific Time, August 31, 2017. Bids and required hard copy forms that do not arrive by the specified date and time WILL NOT BE ACCEPTED. Bidders may submit their bid any time prior to the above stated deadline.**

Note: E-Bids are sealed and cannot be viewed by the City until the closing date and time. If you need to withdraw your bid, you may do so any time before the bid deadline, by going back into the system and selecting "withdraw".

All questions must be submitted in writing and emailed to [purchasingbids@longbeach.gov](mailto:purchasingbids@longbeach.gov)  
ATTN: Michelle King with the bid number in the subject line of the email message.

#### **REFERENCES**

Bidder shall furnish a list of five (5) current customers, including company name, street address, telephone number and contact person, for whom Bidder has provided similar items and quantities. The City intends to contact these customers to determine product reliability, performance and other information. Failure to include customer's references will result in rejection of bids. See Reference Information form attachment.

## **AWARD**

The City prefers to award to a single contractor but reserves the right to award contracts to multiple vendors. The City reserves the right in its sole discretion to award all items to one bidder, or to award separate items or groups of items to various bidders, or to increase or decrease the quantities of any item. The City reserves the right to reject at any time any or all bids.

## **RIGHT TO REJECT BID**

The City reserves the right, in its discretion, to reject any and all Bids and, to the extent not prohibited by law, to waive any minor irregularity or informality in any Bid that does not affect the validity of the Bid or does not give the bidder a competitive advantage over other bidders.

## **BID PROTEST PROCEDURES**

### **Who May Protest**

Only a bidder who has actually submitted a bid proposal is eligible to protest a bid. The City will not accept or entertain bid protests from manufacturers, vendors, suppliers, subcontractors or the like. A bidder may not rely on the bid protest submitted by another bidder, but must timely pursue its own protest.

### **Time for Protest**

A bidder desiring to protest a bid shall file the protest within five (5) business days of the electronic notification of intent to award. The City Purchasing Agent must receive the protest by the close of the business on the fifth (5<sup>th</sup>) business day following posting of notification of intent to award the contract.

### **Form of Protest**

The protest must be in writing and signed by the individual who signed the bid or, if the bidder is a corporation, by an officer of the corporation, and addressed to the City Purchasing Agent. A protest shall not be made by e-mail or fax and the City will not accept such. A protest must set forth a complete and detailed statement of the grounds for the protest and include all relevant information to support the grounds stated, must refer to the specific portion(s) of the contract documents upon which the protest is based, and shall include a valid e-mail address, street address, and phone number sufficient to ensure the City's response will be received.

Once the protest is received by the City Purchasing Agent, the City will not accept additional information on the protest unless the City itself requests it. In that case, the additional information must be submitted within three (3) business days after the request is made and must be received by the City Purchasing Agent by the close of the business on the third (3<sup>rd</sup>) business day.

The City Purchasing Agent or designee will respond, by e-mail or regular mail to the addresses provided in the protest, with a decision regarding the protest within five (5) business days following receipt of the protest or, if applicable, the receipt of requested additional information.

The decision of the City Purchasing Agent shall be final and conclusive.

The procedure and time limits set forth herein are mandatory and are the bidder's sole and exclusive remedy in the event of bid protest. The bidder's failure to comply with these procedures shall constitute a waiver of any right to further pursue a bid protest, including filing a Government Code Claim or initiation of legal proceedings.

#### **ADDITIONAL REQUIREMENTS FROM FUNDING SOURCE**

Any Contract arising from this procurement process may be funded in whole or in part by various granting agencies. Pursuant to said grants, the Awarded Vendor is required to comply with (and to incorporate into its agreements with any sub-vendors) the following provisions in the performance of the Contract, as applicable.

#### **ORDER OF PRECEDENCE**

In the event of conflicts or discrepancies between these grant funding provisions and any other Contract document, the Federal grant provisions shall take precedence.

#### **ACCESS TO CONTRACTOR'S RECORDS**

The Awarded Vendor shall provide the City, the Office of State and Local Government Coordination and Preparedness, the Comptroller General of the United States, or any of their authorized representatives, access to any books, documents, papers, and records of the Awarded vendor which are directly pertinent to the work performed under the Contract for the purposes of making audit, examination, excerpts or transcriptions.

#### **AMERICANS WITH DISABILITIES ACT**

The Awarded Vendor hereby certifies that it will comply, as applicable, with the Americans with Disabilities Act of 1990 ("ADA"), 42 USC §§ 12101 et seq., and its implementing regulations, including Subtitle A, Title II of the ADA. The Awarded Vendor will provide, as applicable, reasonable accommodations to allow qualified individuals with disabilities to have access to and to participate in its programs, services and activities in accordance with the provisions of the ADA. The Awarded Vendor will not discriminate against persons with disabilities or against persons due to their relationship to or association with a person with a disability. Any contract entered into by the Awarded Vendor (or any subcontract thereof), relating to this Agreement, shall be subject to the provisions of this paragraph.

#### **COMPLIANCE WITH CONTRACT WORK HOURS AND SAFETY STANDARDS ACT**

The Awarded Vendor shall comply with the requirements of §§ 103 and 107 of the Contract Work Hours and Safety Standards Act (40 U.S.C §§ 327-330) as supplemented by Department of Labor regulations (29 CFR Part 5).



#### COMPLIANCE WITH COPELAND "ANTI-KICKBACK" ACT

The Awarded Vendor shall comply with the requirements of the Copeland "Anti-Kickback" Act (18 U.S.C. § 874) as supplemented in the Department of Labor regulations (29 CFR Part 3).

#### COMPLIANCE WITH DAVIS-BACON ACT

The Awarded Vendor shall comply with the requirements of the Davis-Bacon ACT (40 U.S.C. §§ 276 to 276-a7) as supplemented by Department of Labor regulations (29 CFR Part 5) where applicable and shall provide the City with all applicable payroll records on a weekly basis.

#### COPYRIGHT

The Awarded Vendor acknowledges the existence of requirements and regulations of the awarding Federal agency relating to copyrights and right in data, including, but not limited to those set forth in 44 CFR Part 13.34 which states: "The Federal awarding agency reserves royalty-free, nonexclusive, and irrevocable license to reproduce, publish or otherwise use, and to authorize others to use, for Federal Government purposes: (a) The copyright in any work developed under a grant, subgrant, or contract under a grant or subgrant; and (b) Any rights of copyright to which a grantee, subgrantee or a contractor purchases ownership with grant support." The Awarded Vendor shall comply with 25 CFR 85.34

#### DRUG-FREE WORKPLACE

The Awarded Vendor hereby certifies that it shall provide or shall continue to provide a drug-free workplace as required by the Drug-Free Workplace Act of 1988 (41 U.S.C. § 701), and implemented at 44 CFR Part 17.

#### ENERGY EFFICIENCY

The Awarded Vendor shall comply with all mandatory standards and policies relating to energy efficiency that are contained in the State of California's energy conservation plan issued in compliance with the Energy Policy and Conservation Act (Pub. L.94-163, 89 Stat. 871).

#### ENVIRONMENTAL LEGISLATION

The Awarded Vendor shall comply with all applicable standards, orders or requirements issued under § 306 of the Clean Air Act (42 U.S.C. 1857 (h)), § 508 of the Clean Water Act (33 U.S.C. 1368), Executive Order 11738, and Environmental Protection Agency regulations (40 CFR Part 15).

#### MINORITY, WOMEN, AND OTHER BUSINESS ENTERPRISE OUTREACH

In accordance with CalOES/Grantor directives, as applicable, firms who represent small business enterprises (SBEs), minority business enterprises (MBEs) and women business enterprises (WBEs) are encouraged to participate in competition for this opportunity. Any such enterprise shall include the appropriate SBE/MBE/WBE certification along with its proposal. The Awarded Vendor agrees that, to the extent contractors or subcontractors are utilized, the Awarded Vendors shall use small, minority, women-owned, or

disadvantaged business concerns and contractors or subcontractors to the extent practicable and shall take the affirmative steps as set forth in 44 CFR §13.36(e).

#### NATIONAL PRESERVATION ACTS

The Awarded Vendor shall assist City (if necessary) in assuring compliance with § 106 of the National Historic Preservation Act of 1966 (16 U.S.C. § 470), Executive Order 11593 (identification and protection of historic properties), the Archeological and Historical Preservation Act of 1974 (16 U.S.C. § 469 a-1 et seq.), and the National Environmental Policy Act of 1969 (42 U.S.C. § 4321)

#### NONDISCRIMINATION; EQUAL EMPLOYMENT OPPORTUNITY

The Awarded Vendor hereby assures the City that in performing its obligations pursuant to the Contract, it will comply with all applicable nondiscrimination requirements as set forth in 44 CFR Part 13.36. In addition, the Awarded Vendor shall comply with Executive Order 11246 of September 24, 1965, entitled "Equal Opportunity Employment," as amended by Executive Order 11375 of October 13, 1967, and as supplemented in Department of Labor regulations (41 CFR chapter 60), and where applicable to the nondiscrimination provisions of the Omnibus Crime Control and Safe Street Acts of 1968 (42 U.S.C. § 3789d), the Victims of Crimes Act (42 U.S.C. § 10604(e)), the Juvenile Justice and Delinquency Prevention Act (42 U.S.C. § 5672(b)), the Civil Rights Act of 1964 (42 U.S.C. § 2000d), the Rehabilitation Act of 1973 (29 U.S.C. § 794), the Americans with Disabilities Act of 1990 (42 U.S.C. §§ 12131-34), the Education Amendments of 1972 (20 U.S.C. §§ 1681, 1683, 1685-86), and the Age Discrimination Act of 1975 (42 U.S.C. §§ 6101-07), see Executive Order 13279 (equal protection of the laws for faith-based and community organizations). This provision must be incorporated by Awarded Vendor into any subcontract exceeding \$10,000.

#### PATENT RIGHTS

The Awarded Vendor acknowledges the existence of requirements and regulations of the awarding Federal agency relating to patent rights with respect to any discovery or invention which arises or is developed in the course or under this Contract, including, but not limited to those regulations and requirements set forth in 44 CFR Part 13.36. Any discovery or invention that arises during the course of this Contract shall be immediately reported to the Department's project management team. The awarding Federal agency shall determine how rights in the invention/discovery shall be allocated consistent with "Government Patent Policy" and 37 CFR Part 401.

#### PAYMENTS, REPORTS, RECORDS, RETENTION AND ENFORCEMENT

The Awarded Vendor acknowledges the requirements and regulations set forth in 44 CFR Parts 13.36 through 13.42 and 49 CFR Part 18 and agrees to cooperate with the City in order to allow the City to comply with said requirements. The Awarded Vendor shall retain all of its records relating to the project for a period of five (5) years after City makes final payment to the Awarded Vendor and all other pending matters are closed.

## PUBLICATIONS

All publications created and/or published with funding under any contract arising from this RFP shall prominently contain the following statement: "This document was prepared under a grant from FEMA's Grant Programs Directorate, U.S. Department of Homeland Security. Points of view or opinions in this document are those of the author(s) and do not necessarily represent the official position or policies of FEMA's Grant Programs Directorate or the U.S. Department of Homeland Security."

## RIGHTS TO DATA

The Grantor and the City shall have unlimited rights or copyright license to any data first produced or delivered under this Agreement. "Unlimited rights" means the right to use, disclose, reproduce, prepare derivative works, distribute copies to the public and perform and display publicly, or permit others to do so; as required by 48 CFR 27.401. Where the data are not first produced under this Contract or are published copyrighted data with the notice of 17 U.S.C § 401 or 402, the Grantor acquires the data under copyright license as set forth in 48 CFR 27.404(f) (2) instead of unlimited rights (4 CFR 27.404(a)).

## RIGHTS TO USE INVENTIONS

City and all grantors and/or awarding Federal Agency shall have an unencumbered right, and a non-exclusive, irrevocable, royalty-free license, to use, manufacture, improve upon and all others to do so for all governmental purposes, any Invention developed under the Contract.

## SYSTEM FOR AWARD MANAGEMENT (SAM)

In accordance with Executive Orders 12549 and 12689 concerning suspension and debarment, contracts must prohibit contractors from awarding any subcontract to persons (individuals or organizations) listed as having an active exclusion of the Federal system for Awards Management Database ([www.sam.gov](http://www.sam.gov)).

## FUTURE AMENDMENTS

The City reserves the right to change any portion of the work required, to add and/or delete items, or amend such other terms and conditions that may become necessary. Any such revisions shall be accomplished by written amendment to the contract and executed by the Contractor and the City.

## DELIVERY REQUIREMENT

Equipment, material, supplies or services shall be delivered FOB Destination City of Long Beach, 2600 Temple Ave, Long Beach, CA 90806.

Estimated Day of Delivery (ARO) 210-270 DAYS ARO

## PAYMENT TERMS

Net 30; 0 % discount in 30 days.

**VENDOR CONTACT INFORMATION**

Name of a person that will be the City's contact for order placement, order problems or special needs, etc. (must have a person's name).

Contact Name: RON CREIGHTON

Contact Direct Phone: (909) 510-4406

Contact Fax: (562) 447-1544

Contact E-mail: rcreighton@lafreightliner.com

**VENDOR'S EMPLOYEES**

Specify the number of current full-time employees residing in Long Beach 6

**ITB FS 17-137 Appendix A  
ROLL OFF TRUCKS**

COMPLY  
YES NO

COMMENTS / EXCEPTIONS

<p><b><u>Instructions:</u></b></p> <p>State comments and or exceptions in the blank spaces provided for each section regarding the vehicle or equipment offered corresponding to the specifications set forth. FAILURE TO COMPLETE ALL BLANK SPACES SHALL OTHERWISE BE DETERMINED AS VENDOR MEETING SPECIFICATIONS MINIMUMS.</p>	<p>YES</p>		
<p><b><u>Description</u></b></p> <p>Shall be (4) four Autocar low entry cab forward with set back front axle, tilt cab, left-hand drive only, three axle, CNG dedicated, cab and chassis with a roll off type body collection unit attached to the truck frame for the purpose of hauling 20 yard roll off containers.</p>	<p>YES</p>		
<p><b><u>General</u></b> It is the intent of the following specifications to describe a new automated roll off collection truck:</p> <ol style="list-style-type: none"> <li>1. The body, finish and fittings shall be the latest model, shall not have been used in demonstrator or other service, and shall be <u>factory standard</u> in all respects not in conflict with the following specific requirements. All work and material furnished shall be subject to the approval of the Fleet Services Bureau.</li> <li>2. These specifications indicate minimum requirements for the needs of the City of Long Beach as concerns this equipment. However, it shall in all respects meet standards and safety requirements established for equipment of this type by the appropriate State and Federal Agencies.</li> <li>3. Evidence of compliance with requirements of these specifications and those of the above agencies shall be based on manufacturer's data sheets applicable to this equipment. Such data sheets shall be included with and made a part of this quotation. Bids shall be considered on equipment complying substantially with these specifications, provided all deviations are stated and all substitutions are described, including technical data where applicable, in a letter</li> </ol>	<p>YES  YES  YES</p>		

**ITB FS 17-137 Appendix A  
ROLL OFF TRUCKS**

COMPLY  
YES NO

COMMENTS / EXCEPTIONS

<p>attached to the bid. The City of Long Beach reserves the right to determine whether such substitutions are within the intent of these specifications and shall reasonably meet the service requirements of the City of Long Beach.</p> <p>4. All bids must be submitted in duplicate including manufacturer's data sheets and brochures.</p> <p>5. Bidders shall state the time required for delivery, and quotations shall include delivery to the City of Long Beach at 2600 Temple Ave., Long Beach Ca. 90806.</p>	<p>YES</p> <p>YES</p> <p>YES</p>		
<p><b>BRAND NAMES:</b></p> <p>Whenever in the specifications any material or process is indicated or specified by patent or proprietary name and/or by name of manufacturer, such specifications shall be used for the purpose of facilitating descriptions of the material and/or process desired and shall be deemed to be followed by the words "or equivalent".</p> <p>The contractor may offer any material or process which shall be equal in every respect to that so indicated or specified, provided however, that if the material, process or article offered by the contractor is not, in the opinion of the City of Long Beach, equal in every respect to that specified, then the contractor must furnish the material, process or article specified or one that in the opinion of the City of Long Beach is the equal thereof in every respect.</p>	<p>YES</p> <p>YES</p>		
<p><b><u>DELIVERY:</u></b></p> <p>Delivery of the vehicle shall be to Fleet Services Bureau located at 2600 Temple Ave. Long Beach, CA 90808. The truck shall be under its own power to allow for "break-in" period. Delivery shall be <u>210-270</u> days from ARO. Please state number of delivery days.</p>	<p>YES</p>		

**ITB FS 17-137 Appendix A  
ROLL OFF TRUCKS**

COMPLY  
YES NO

COMMENTS / EXCEPTIONS

<p><b>Conditions:</b> The design of the complete unit shall embody the latest approved automotive engineering practices and the workmanship must be of the highest quality in its respective field. The Contractor shall be responsible for the integrity of the completed unit. The unit shall be completely equipped as specified and be ready for immediate service upon delivery. The unit shall comply with the latest editions of the California Vehicle Code, California Code of Regulations, SAE Standards, Federal Motor Vehicle Safety Standards, DOT Standards, provisions of Cal/OSH0A, and ANSI Z245.1 Safety Standards. The omission from the specifications of any standard feature as shown in the manufacturer's brochure shall not alleviate the Contractor from their responsibility of furnishing a roll off truck with all of the manufacturer's latest improvements in current production unless specifically deleted in the specifications. The complete unit(s) and all components shall be standard production items unless otherwise specified.</p>	<p>YES</p>		
<p><b>CERTIFIED GVWR:</b>  Shall be at least 60,000 lbs.</p>	<p>YES</p>		
<p><b>CALIFORNIA LEGAL PAYLOAD:</b>  Shall be capable of transporting a minimum California Legal Payload of 8 tons. The weight shall be demonstrated on certified scale with first truck delivered.  Note: Successful bidder shall supply the City of Long Beach with a certified weight distribution analysis that verifies the payload. <b>No Exceptions</b></p>	<p>YES  YES</p>		
<p><b>Wheelbase:</b>  Shall not exceed 219".</p>	<p>YES</p>		
<p><b>Length:</b>  Overall length of complete truck shall not exceed 360" inches.</p>	<p>YES</p>		

**ITB FS 17-137 Appendix A  
ROLL OFF TRUCKS**

COMPLY  
YES NO

COMMENTS / EXCEPTIONS

	COMPLY YES NO	COMMENTS / EXCEPTIONS
<p><b><u>Width:</u></b></p> <p>Unit shall not exceed maximum legal California width of 106" including tarping system.</p>	<p>YES</p>	
<p><b><u>Engine:</u></b></p> <p>Shall be a Cummings 8.9L ISL G NZ, or approved equal, dedicated CNG, 4 cycle, turbo charged with at least 280-horse power, 900 ft. lbs. of torque at 2100 r.p.m. Engine shall be compatible with the transmission and driveline and shall be certified by the manufacturer as a specific acceptable combination for heavy-duty stop and go roll off pick up service. Engine servicing shall be accessible without tilting cab. Engine shall be equipped with electronic controls, and charged air cooler. Engine shall also be equipped with full flow type, spin on oil filter, spin on water filter and must be equipped with a 30 second warning before shut down for low oil pressure or high coolant temperature. Engine must have 350-ft. lbs. of torque available at idle.</p>	<p>YES</p>	<p>*NOTE: CURRENTLY THERE IS GRANT OPPORTUNITIES THRU THE SCAQMD HVIP PROGRAM FOR THE DELTA COST FROM CHASSIS OEM TO COVER THE COST BETWEEN THE ISL G AND ISL G NZ (NEAR ZERO). FOR AUTOCAR CHASSIS THE GRANT OPPORTUNITY IS \$8,500.00, THIS GRANT IS SUBJECT TO THE AVAILABILITY OF FUNDS AT THE TIME OF ORDER AND SUBJECT TO CUSTOMER QUALIFICATION TO INCLUDE THE USE FOR VEHICLES FUELED WITH RENEWABLE NATURAL GAS (RNG). GRANT MONIES ARE DEDUCTED FROM VEHICLE PRICE AFTER APPLICABLE TAXES &amp; FEES AND ARE APPLIED FOR BY CERTIFIED HVIP TRUCK DEALERSHIPS.</p>
<p><b><u>Engine Air Cleaner:</u></b></p> <p>Shall be 14" or larger horizontally mounded, dry type, approved by engine manufacturer. System shall have a restriction indicator visible to operator on dash. Intake shall be above cab roofline with an appropriate cover, filter, and strainer.</p>	<p>YES</p>	<p>15" HORIZONTALLY MOUNTED. AIR RESTRICTION INDICATOR ON HOUSING</p>
<p><b><u>Engine Cooling System:</u></b></p> <p>Shall be largest, heaviest, increased capacity system available for engine and transmission specified, minimum 1,200 square inch bolted tank or approved equal. Cooling shall be field tested and certified by the manufacturer for heavy-duty stop and go roll off pick-up service. System shall include a spin on type cooling system filter. All hoses shall be Gates Green Stripe, or approved equal with constant torque hose clamps. <u>Silicone hoses are not acceptable.</u></p>	<p>YES YES YES</p>	<p>1,300 SQ. INCH RADIATOR - LARGEST IN CLASS</p>



**ITB FS 17-137 Appendix A  
ROLL OFF TRUCKS**

COMPLY  
YES NO

COMMENTS / EXCEPTIONS

<p><b><u>Engine Exhaust System:</u></b></p> <p>Shall be stainless steel heat shielded, left side vertical mount, quiet design type with an appropriate elbow or rain cap at exit, and extended above roof of cab and roll off body. No flex joint accepted.</p>	<p>YES</p>		
<p><b><u>Transmission:</u></b></p> <p>Shall be automatic, torque converter type with at least five (5) speeds forward and one (1) in reverse with cast aluminum, or approved equal, low ground clearance, oil pan. Controls to be electronic shift. Also roll off body hydraulic system pump shall not be engaged until engine is at idle and then operated when transmission is in gear. The chassis manufacturer shall install the programming option and group that best match the application described in the specifications. The chassis manufacturer prior to delivery of the cab and chassis to the body manufacturer shall program the transmission E.C.U. The chassis manufacturer shall provide an electrical junction box(s) outside of the vehicle interface module for all roll off body electrical connections. The junction box(s) shall have all circuits clearly identified. All chassis to body electrical connections must be made inside of the junction box(s). Transmission shall be equipped with an</p> <p>oil level sensor to allow fluid level to be displayed in dash. Allison transmission HD4560P or approved equal, electronic shift type push button keypad, oil cooler inside radiator and external oil filter, spin on type.</p>	<p>YES</p> <p>YES</p>		<p>NOTE: OPTION - ALLISON 3000RDS DEDUCT \$6,800.00 FROM BID PRICE BEFORE APPLICABLE TAXES.</p> <p>*NOTE: SUPPLYING ALLISON 4500RDS (HD4560P IS OLDER MODEL)</p> <p>*NOTE: FOR ALLISON 3000RDS DEDUCT \$6,800 FROM BID PRICE BEFORE TAXES</p>
<p><b><u>Frame:</u></b> Shall meet the following minimums:</p> <ol style="list-style-type: none"> <li>1. Shall be of channel construction.</li> <li>2. Shall be of sufficient strength to withstand the heavy strains of roll off truck service.</li> <li>3. Huck bolted construction with full-length liner on frame rails. <b><u>Welded construction unacceptable.</u></b></li> <li>4. Shall be 17" minimum section modulus per rail.</li> </ol>	<p>YES</p> <p>YES</p> <p>YES</p> <p>YES</p>		





**ITB FS 17-137 Appendix A  
ROLL OFF TRUCKS**

COMPLY  
YES NO

COMMENTS / EXCEPTIONS

<p>Spring Hangers, if applicable, shall be of fabricated steel. <b><u>Cast iron or aluminum is unacceptable.</u></b> <b>Rear:</b> 1. Hendrickson Haulmax 40,000 lb. capacity rear spring suspension, or approved equal.</p>	<p>YES  YES</p>		
<p><b><u>Steering:</u></b> Shall meet the following minimums:  1. Shall be factory left-hand. 2. Shall be power with integral valving. 3. Power steering pump shall be gear driven. 4. Steering gearbox shall be at least 20,000 lbs. rating. Ross, Sheppard, Saginaw brand, TRW or approved equal. 5. Turning radius shall have at least a 45-degree wheel cut. 6. There shall be adequate leg, thigh, and elbowroom at steering wheel. 7. Steering wheel shall be able to adjust up, down, and telescope in and out to accommodate drivers of different statures.</p>	<p>YES YES YES YES YES YES YES</p>		<p>(5). 50 DEG WHEEL CUT - BEST IN-CLASS</p>
<p><b><u>Drive Shafts:</u></b>  Shall be needle bearing type of adequate size, Meritor Main Driveline with full round yokes. minimum. Shaft slip joints shall be "Glide-Cote" type or approved equal. All drivelines shall have take-apart flanges.</p>	<p>YES</p>		
<p><b><u>Wheels:</u></b> Shall be certified by the manufacturer for use with this vehicle.  1. <b>Front:</b> Two (2) ten (10) tapered hole "Budd" type, 5-hole ventilated or approved equal, aluminum alloy wheels to accept 315/80R X 22.5 tubeless tires. 2. <b>Rear:</b> Eight (8) ten (10) tapered hole "Budd" type, 5-hole ventilated or approved equal, aluminum alloy wheels to accept 315/80Rx22.5 tubeless tires. All wheels shall be aluminum alloy. One (1) spare front and rear wheel shall be provided for each unit delivered.</p>	<p>YES  YES</p>		

**ITB FS 17-137 Appendix A  
ROLL OFF TRUCKS**

COMPLY  
YES NO

COMMENTS / EXCEPTIONS

	COMPLY YES	NO	COMMENTS / EXCEPTIONS
<p><b><u>Tires:</u></b> Minimums</p> <ol style="list-style-type: none"> <li>1. Front: Two (2) 315/80R X 22.5 LR"L" premium grade, steel radial ply casing construction, Michelin XZY2, balanced, tubeless type.</li> <li>2. Rear: Eight (8) 315/80R X 22.5 LR"L" premium grade, steel radial ply casing construction Michelin XZY2 tubeless type.</li> <li>3. One (1) spare front and rear tire shall be provided for each unit delivered.</li> </ol>	YES		
<p><b><u>Electrical:</u></b> Shall meet the following minimums:</p> <ol style="list-style-type: none"> <li>1. Twelve (12) volt, negative ground system.</li> <li>2. System shall be protected with adequate circuit breakers. Fuses unacceptable.</li> <li>3. All wiring shall be loomed and routed the simplest, most direct and most protected way with separate accessory and body functions to a frame mounted weatherproof junction box. <u>No splicing shall be allowed by roll off body installer.</u> Wiring shall be supported or clamped at intervals not to exceed thirty (30) inches.</li> <li>4. One positive and one negative accessory terminal shall be centrally located on the dash and individually protected by circuit breakers (for radios).</li> <li>5. <u>Manufacturer shall provide color-coded wiring diagram per build with first unit delivered.</u></li> </ol>	YES YES YES YES YES		
<p><b><u>Alternator:</u></b></p> <p>Shall be not less than two hundred (200) ampere manufacturer's rated capacity with external rectifier and R-stator terminal.</p>	YES		
<p><b><u>Starter:</u></b></p> <p>Delco Remy 42 MT 400 starter, or approved equal, with magnetic switch for solenoid at or near starter motor with 00 minimum size cables and overheat protection.</p>	YES		

**ITB FS 17-137 Appendix A  
ROLL OFF TRUCKS**

COMPLY  
YES NO

COMMENTS / EXCEPTIONS

<p><b>Battery(s):</b> Shall meet the following minimums:</p> <ol style="list-style-type: none"> <li>1. All Battery(s) shall be mounted outside of frame rails as far forward as practical or in a location agreed upon by the City of Long Beach and body builder, in a steel or anodized aluminum box on left or right side, and protected from road debris. Battery box cover or liner shall be constructed of a non-metallic material.</li> <li>2. Each battery shall be 900 CCA group 31, heavy-duty maintenance free type, Delco, Gould or approved equal. (3 each)</li> <li>3. Battery cut-off switch to be provided.</li> </ol>	<p>YES</p> <p>YES</p>		
<p><b>Fuel Tank:</b></p> <p>Tank shall be constructed to DOT standards approved for use with CNG, easily accessible fill with body configuration, useable 80 DGE capacity, with emergency shut off valve. Dual 40-gallon tanks shall be mounted on both sides, and have a visible pressure gauge.</p>	<p>YES</p>		
<p><b>Fuel Gauge:</b></p> <p>Empty to full needle type gauge, dashboard mounted, visible to operator, gauge to monitor CNG levels in the fuel system and clearly marked CNG, Tank sending unit shall be of heavy-duty quality and approved by the City of Long Beach.</p>	<p>YES</p>		
<ol style="list-style-type: none"> <li>1. <b>Cab:</b> Shall meet the following minimums:</li> <li>2. Current production, two (2) man, tilt cab, low entry design, at least 89" inches wide with mud flaps at rear of front wheels. Cab shall be same manufacturer as frame rails.</li> <li>3. Instrument panel shall include at least the following control and indicator gauges: tachometer, speedometer, oil pressure, water temperature, air pressure, fuel gauge, voltmeter, oil pressure activated engine hour meter, headlights, dome lights, dash lights, ignition switch with key, heater/defroster, air</li> </ol>	<p>YES</p> <p>YES</p>		

**ITB FS 17-137 Appendix A  
ROLL OFF TRUCKS**

COMPLY  
YES NO

COMMENTS / EXCEPTIONS

	COMPLY YES NO	COMMENTS / EXCEPTIONS
conditioning, windshield wipers, emergency brakes, 4. hydraulic PTO switch, turn signals, horn, hazard lights, night working lights (arm/hopper) etc	YES	
5. Left-hand drive, sit down/seat, with left-hand instrumentation.	YES	
6. No controls or hardware on right side of cab. All controls and hardware to be on left side of cab only – no exceptions.	YES	
7. Instruments shall be Stewart Warner "Delux" or approved equal.	YES	
8. Conventional doors, right and left sides, with piano style hinges and brass or stainless steel pins and grab handles.		NO (8). PIANO STYLE HINGES NOT AVAILABLE ON AUTOCAR ACX.
9. 30,000 BTU fresh air heater and integral defroster.	YES	30,000 BTU A/C AND 50,000 BTU HEATER
10. Full width windshield(s) and rear cab window(s). All glass shall be tinted.	YES	
11. Sun visors, right and left sides.		
12. Left side driver's seat shall be Bostrom mid-back air suspension.	YES	
13. Passenger seat shall be Bostrom mid-back non-suspended.	YES	
14. Both seats shall be equipped with three point seat belts with retractors and adjustable D rings. Adequate knee and elbow room shall be engineered into the cab design.	YES	
15. Upholstery shall be heavy-duty cloth. Any sound deadening material used in cab interior shall be matching colors. Any sound deadening material used in engine areas shall be resistant to absorption of oil and water and be fireproof.	YES	
16. Mirrors shall be black one-piece dual pane non-heated remote controlled.	YES	
17. Dual windshield wipers.	YES	
18. Cab tilt mechanism shall be hydraulic and or electric. Tilt shall be at least 60 degrees and expose engine and components for repair.	YES	
19. Front bumper shall be ¼" steel, painted, with tow hooks, frame mounted, and of sufficient strength to permit lifting and towing of a fully loaded vehicle without damage to cab assembly or components. Bumper shall be extended twelve (12)" forward of cab to protect cab from damage.	YES	*NOTE BUMPER 12" FORWARD OF CAB NOT NECESSARY.

**ITB FS 17-137 Appendix A  
ROLL OFF TRUCKS**

COMPLY  
YES NO

COMMENTS / EXCEPTIONS

<p>20. Occupants inside of cab shall not be subjected to over 85 DBA per SAE J336A, or Cal OSHA General Orders under full throttle load acceleration.</p> <p>21. Engine/transmission electronic diagnostic equipment with software for appropriate engine and transmission shall be provided with first unit delivered. The manufacturer shall provide diagnostic training before first unit is delivered.</p> <p>22. Vehicle to be equipped with factory air conditioning.</p> <p>23. Shall be equipped with an AM/FM radio/Aux input.</p> <p>24. Cab shall be warranted by manufacturer for a minimum of one year from the City of Long Beach in-service date.</p> <p>25. An additional control pad shall be installed on the right hand side of operator. Location shall be determined at time of bid award.</p>	<p>YES</p> <p>YES</p> <p>YES</p> <p>YES</p> <p>YES</p> <p>YES</p>		
<p><b><u>Additional Truck Chassis Equipment:</u></b></p> <p>1. Back-up alarm, electric, with motion detector, Cal OSHA approved.</p> <p>2. Reflector flare kit mounted in cab, Grote 71422, or approved equal.</p> <p>3. Roll off body hydraulics operation system. Warning light(s) at dash shall show hydraulic pump engaged and roll off body hydraulic system in operation mode.</p> <p>5. Warning light and buzzer shall also show roll-off rails <b>not</b> in stowed position.</p> <p>6. 10# ABC fire extinguisher.</p> <p>7. One (1) Rear vision camera 3<sup>rd</sup> Eye Mobile Vision model AWT1020T, and monitor model number AWT07MLEDT, or approved equal. Camera shall be located on rear of roll off body.</p>	<p>YES</p> <p>YES</p> <p>YES</p> <p>YES</p> <p>YES</p> <p>YES</p>		
<p><b><u>Roll Off Body:</u></b></p> <p>1. Roll off body shall be an all welded construction of steel sections.</p> <p>2. All body areas shall be adequately reinforced to allow continuous operation with maximum loads and prevent excessive wear and deformation.</p>	<p>YES</p> <p>YES</p>		



**ITB FS 17-137 Appendix A  
ROLL OFF TRUCKS**

	COMPLY		COMMENTS / EXCEPTIONS
	YES	NO	
<p>3. All hoses shall be installed and protected in such a way as to prevent damage.</p> <p>4. All body welding fillets shall have good penetration, good fusion, good appearance, and shall not display cracks or undercutting.</p> <p>5. Body shall be warranted bumper to bumper by manufacturer for a minimum of three years from the City of Long Beach in-service date.</p>	<p>YES</p> <p>YES</p> <p>YES</p>		<p>5. HYDRAULIC CYLINDER WARRANTY 5 YRS./ HYDRAULIC PUMP WARRANTY 2 YRS.</p>
<p><b><u>Tarping System:</u></b></p> <p>1. Shall be equipped with an O'Brian AutoCover II-CH automatic tarping system.</p> <p>2. Tarping system shall cover the entire load when roll-off container is on the truck.</p> <p>3. Shall have three (3) controls mounted street side behind cab.</p> <p>4. Controls shall be mounted rear of cab front of roll off container and perform the following:</p> <ul style="list-style-type: none"> <li>• Control tarp up and down.</li> <li>• Control tarp arms to extend from front of roll off container to rear.</li> <li>• Control tarp arms to be able to adjust tarp tautness after covering load.</li> </ul> <p>5. Tarp shall be mess type with a minimum of four (4) inches overhang on each side for covering of load.</p> <p>8. Tarp shall be mounted behind cab ahead of roll off body in covered cavity for element protection.</p> <p>9. Tarp case shall be spring type so as to roll back automatically when returning to stowed position.</p> <p><b><u>Main Rail:</u></b></p> <p>Shall be constructed with a minimum of 10" x 4" x 1/2" steel tubing with 1/2" x 3" wear strip.</p>	<p>YES</p> <p>YES</p> <p>YES</p> <p>YES</p> <p>YES</p> <p>YES</p> <p>YES</p> <p>YES</p>		
<p><b><u>Cylinders:</u></b></p> <p>Shall be a single stage cylinder, 6 1/4" bore x 80" stroke.</p>	<p>YES</p>		

**ITB FS 17-137 Appendix A  
ROLL OFF TRUCKS**

COMPLY  
YES NO

COMMENTS / EXCEPTIONS

	COMPLY YES	NO	COMMENTS / EXCEPTIONS
<p><b><u>Controls:</u></b></p> <ol style="list-style-type: none"> <li>1. Shall be equipped with interior and exterior controls and a three-section spool valve.</li> <li>2. Shall have pneumatic inside controls mounted in console along with PTO and safety equipment.</li> </ol>	YES		
<p><b><u>Sheaves:</u></b></p> <ol style="list-style-type: none"> <li>1. All sheaves shall be interchangeable.</li> <li>2. Sheaves shall be constructed of 11" diameter cast steel with aluminum/bronze bushing and a 2 1/2" pin.</li> </ol>	YES YES		
<p><b><u>PTO:</u></b></p> <p>Shall be air shift type, direct mounted, driven off engine crankshaft.</p>	YES		
<p><b><u>Hydraulic System:</u></b></p> <ol style="list-style-type: none"> <li>1. Pump shall be a single stage Commercial P-51, or approved equal, steel constructed, driven off the engine crankshaft, capable of 28 GPM at 1200 RPM. (Aluminum housing or components not acceptable). Pump not to protrude past front of cab.</li> <li>2. System shall be capable of operating at 1200 RPM. Maximum operating pressure shall be 2,500 p.s.i.</li> <li>3. Hydraulic system shall incorporate adjustable relief valves to protect all components.</li> <li>4. All hydraulic tubes shall be securely clamped to prevent vibration, abrasion, and excessive noise.</li> <li>5. All hydraulic hoses shall conform to S.A.E. standards for designed pressure.</li> <li>6. Bends shall not be less than recommended by S.A.E standards.</li> <li>7. Flat spots in hoses shall not be acceptable.</li> <li>8. All high-pressure hoses shall be sheathed with fabric protective covering.</li> <li>9. The return line spin on type filter shall also include an in-cab filter by-pass monitor, which shall alert the operator or service personnel when the filter is in need of replacement.</li> </ol>	YES YES YES YES YES YES YES YES YES		

**ITB FS 17-137 Appendix A  
ROLL OFF TRUCKS**

COMPLY  
YES NO

COMMENTS / EXCEPTIONS

<p>10. A hydraulic pump shutdown system shall also be included which shall prohibit prolonged operation of the hydraulics when the filter is in the by-pass mode.</p> <p>11. All multi-spool control valves shall be a section design such that servicing would not require replacement of the entire valve assembly.</p> <p>12. All hydraulic schematics shall be provided per built unit.</p> <p>13. Hydraulic pump shall be warranted by manufacturer for a minimum of two years from the City of Long Beach in-service date.</p>	<p>YES</p> <p>YES</p> <p>YES</p> <p>YES</p>		
<p><b>Hydraulic Reservoir:</b></p> <p>1. Hydraulic reservoir shall be a minimum of 45 gallons.</p> <p>2. Shall have a shut-off valve on the suction side.</p> <p>3. A high-pressure filter shall be installed on the discharge side of the pump.</p> <p>4. Hydraulic oil cooler shall be installed in the system.</p> <p>5. Total system capacity shall be approximately 65 gallons.</p> <p>6. A 25-micron filter shall be in the return line.</p> <p>7. System shall have a 100-micron mesh suction strainer with magnet.</p> <p>8. Shall have drain at bottom of tank.</p> <p>9. Tank to have protected sight glass with temperature indicator built into sight glass.</p>	<p>YES</p> <p>YES</p> <p>YES</p> <p>YES</p> <p>YES</p> <p>YES</p> <p>YES</p> <p>YES</p> <p>YES</p>		
<p><b><u>Roll off components:</u></b></p> <p><b><u>Rear Hinge:</u></b></p> <p>1. Extra heavy-duty 2 1/2" X 40 3/4" solid steel shaft.</p> <p>2. 8 inch bushing each side (total bushing area shall be 16".)</p> <p><b><u>Dump Angle:</u></b></p> <p>1. 47 to 52 degrees.</p> <p>2. Final dump angle depends on chassis layout- (wheel base and frame layout).</p> <p><b><u>Cable:</u></b></p> <p>7/8 inch X 80 inches with shoe style steel casting.</p>	<p>YES</p> <p>YES</p> <p>YES</p> <p>YES</p> <p>YES</p>		

**ITB FS 17-137 Appendix A  
ROLL OFF TRUCKS**

COMPLY  
YES NO

COMMENTS / EXCEPTIONS

	COMPLY YES NO	COMMENTS / EXCEPTIONS
<p><b><u>Front stops:</u></b></p> <p>1 inch steel plate fully welded in the main rails.</p> <p><b><u>Container Locks:</u></b></p> <p>1. Front: automatic gravity pin type on each side.</p> <p>2. Rear: nylon strap with hook and ratchet each side.</p> <p>3. Both need to meet DOT and ANSI standards.</p> <p><b><u>Rollers:</u></b></p> <p>1. Rear 8" X 21" replaceable.</p> <p>2. Side: 3 3/4 inch with aluminum- bronze bushings, grease able, 2 easy replacement pins (5 per side).</p> <p><b><u>Rear Chassis Components: (shall be)</u></b></p> <p><b><u>Rear Bumper:</u></b></p> <p>4" X 6" X 1/2" tubing. Drilled to accommodate rear lights.</p> <p><b><u>Fenders:</u></b></p> <p>Steel tread plate: two piece, interchangeable, shock mounted.</p> <p><b><u>ICC Bumper:</u></b></p> <p>Automatic Fold up.</p>	<p>YES</p> <p>YES</p> <p>YES</p> <p>YES</p> <p>YES</p> <p>YES</p> <p>YES</p> <p>YES</p> <p>YES</p> <p>YES</p> <p>YES</p>	
<p><b><u>Hydraulic Control valves:</u></b></p> <p>1. Shall be electric over hydraulic.</p> <p>2. Shall be Commercial Intertech VA-20 or approved equal.</p> <p>3. Three section spool valve.</p>	<p>YES</p> <p>YES</p> <p>YES</p>	
<p><b><u>Electrical:</u></b></p> <p>1. All electrical wiring connectors to be automotive double-seal, with wiring in split convoluted loom.</p>	<p>YES</p>	

**ITB FS 17-137 Appendix A  
ROLL OFF TRUCKS**

COMPLY  
YES NO

COMMENTS / EXCEPTIONS

<p>2. All wiring connections to be soldered with rubber-molded covering or crimp type connectors with shrink-wrap. <b><u>Unprotected wiring in any application is unacceptable.</u></b></p> <p>3. All electrical limit switches shall be epoxy impregnated to minimize effects of excess moisture.</p> <p>4. All electrical schematics shall be provided as per built unit.</p> <p><b><u>Weight scale:</u></b></p> <p>Shall be equipped with a SI 100 weight scale to monitor load carrying capacity.</p>	<p>YES</p> <p>YES</p> <p>YES</p> <p>YES</p>		
<p><b>LIGHTING:</b></p> <p>1. <b><u>Body Lighting:</u></b> All cab and body lighting shall be LED type rubber flush mounted type. Rear stop and directional lights shall be mounted in rear bumper with appropriate bracketry and protection. Backup, tail and stoplights shall be rubber flush mount type. Clearance lights shall be rubber flush mount. Vehicle shall be equipped with a mid-body turn signal and front and rear identification lights, if required. All wiring shall be number coded, waterproof, mechanically protected and concealed in channel and/or sealed in conduit. Any time a wire passes through metal, the hole shall have a rubber grommet.</p> <p>2. <b><u>Reflectors:</u></b> All reflectors shall be 3" minimum diameter with an aluminum or plastic base.</p> <p>3. <b><u>License Plate:</u></b> There shall be provision for mounting the license plate, properly illuminated.</p> <p>4. <b><u>Mudguards:</u></b> Shall be provided and installed, to comply with law, and prevent water, mud, and debris from getting on batteries, fuel tank, cab, or rear body steps. Mudguards, properly braced, shall be installed forward of the rear axle and at front axle, as applicable.</p>	<p>YES</p> <p>YES</p> <p>YES</p> <p>YES</p>		

**ITB FS 17-137 Appendix A  
ROLL OFF TRUCKS**

COMPLY  
YES NO

COMMENTS / EXCEPTIONS

<p><b>Paint: Cab:</b> The cab excluding wheels, frame, and any bright metal or chromed accessories, shall be painted standard manufacturers white. All surfaces to receive at least a four mil. thickness coating of No. 817, or approved equal, per requirements of the South Coast Air Quality Management District of California. Dupont Corlar 5,000-epoxy primer, or approved equal, shall be used under all polyurethane enamel topcoats.</p> <p>1. <b>Frame:</b> The frame shall be painted with Sikkens, or approved equal, gloss black acrylic enamel with hardener.</p>	YES		
<p><b>Compliance:</b></p> <p>The vehicle purchased, at time of manufacture, shall meet all applicable sections of the U.S. code of Federal Regulations (CFR), including Design and Vehicle Certification, Federal Motor Vehicle Safety Standards (FMVSS), U.S. environmental Protection Agency (EPA) exhaust emission discharge regulations applicable to the design and manufacture of this size and type Heavy Automotive Vehicle.</p> <p>The vehicle purchased, at time of manufacture, shall also meet all applicable laws and regulations of the State of California. This shall include, but not limited to, the California code of Regulations (CCR), Title 13, Motor Carrier Safety Regulations, Southern California Air Quality Management District, California Vehicle code and the California Air Resources Board (CARB).</p>	YES		
<p><b>Vehicle Welding:</b></p> <p>All welding procedures used throughout the construction of the entire vehicle, including materials, qualifications and training of personnel, shall be within all applicable Guidelines and Standards of both the American Society for</p> <p><b>Vehicle Welding:</b> (continued)</p> <p>Testing and Materials (ASTM) and the American Welding Society (AWS). Structural welding of steel shall meet AWS D1.1-83 and structural welding of aluminum shall meet AWS D 1.2-83.</p>	YES		
<p>Testing and Materials (ASTM) and the American Welding Society (AWS). Structural welding of steel shall meet AWS D1.1-83 and structural welding of aluminum shall meet AWS D 1.2-83.</p>	YES		



**ITB FS 17-137 Appendix A  
ROLL OFF TRUCKS**

COMPLY  
YES NO

COMMENTS / EXCEPTIONS

<p>notification by telephone.</p> <p>2. If the contractor does not acknowledge after two (2) working days, it shall be assumed as approval for the City to repair the vehicle or obtain warranty outside vendor repair facility. The City shall be paid an area average hourly rate for labor inclusive of transportation and parts replaced one for one repairs from component manufacturers.</p> <p>3. The vehicle manufacturer shall furnish all warranty documentation to the City.</p> <p>4. Defective parts shall be labeled and retained by the City until parts are replaced. Contractor shall take full responsibility for returning any defective parts to his supplier.</p> <p>5. Outside vendor repair facility parts and labor billing to go directly to manufacturer.</p>	<p>YES</p> <p>YES</p> <p>YES</p> <p>YES</p>		
<p><b><u>Plans and Engineering Conference:</u></b></p> <p>Within 30 days after the contract has been awarded, the manufacturer shall participate in an engineering meeting at which time the entire specification for the equipment shall be reviewed by both the manufacturer and the City of Long Beach Fleet personnel so both parties fully understand how the equipment shall be made. This meeting shall be held at a mutually agreed upon time at the City of Long Beach Fleet Services Yard located at 2600 Temple Ave., Long Beach, California 90806. All expenses shall be absorbed by the contractor including Food, lodging, and travel for the contractor or manufacturer representative.</p>	<p>YES</p>		
<p><b><u>Inspection Trips:</u></b></p> <p>Prior to painting, the City of Long Beach shall send 3 inspectors to the manufacturer's plant for a final pre-delivery inspection to verify that the <b>PRE-PAINT INSPECTION:</b> automated roll off truck has been manufactured and is in compliance with the City of Long Beach's specifications. All expenses shall be paid for by the manufacturer including food, lodging and travel.</p>	<p>YES</p>		<p>*AUTOCAR TRUCK - HAGERSTOWN, INDIANA *AMREP BODY - ONTARIO, CA.</p>



**ITB FS 17-137 Appendix A  
ROLL OFF TRUCKS**

COMPLY  
YES NO

COMMENTS / EXCEPTIONS

	COMPLY YES NO	COMMENTS / EXCEPTIONS
<p><b><u>Legals:</u></b></p> <ol style="list-style-type: none"> <li>1. Contractor shall furnish a certified weight slip with each completed vehicle.</li> <li>2. Must meet all requirements of the South Coast Air Quality Management District (SCAQMD), at the time of bid award.</li> <li>3. Must comply with all Federal and State regulations and must meet all standards of safety for this type of equipment.</li> <li>4. Successful bidder must supply the City of Long Beach with a certified weight distribution analysis that verifies the legal payload of vehicle is in compliance with the California bridge law.</li> <li>5. Contractor shall furnish all paperwork necessary for DMV registration at time of delivery. <b><u>(no exceptions)</u></b>.</li> </ol>	<p>YES  YES  YES  YES  YES</p>	
<p><b><u>Training:</u></b> Successful bidder shall be required to train operators one full day and to train mechanics in preventative maintenance and specialized repair of equipment one full day.</p>	<p>YES</p>	
<p><b><u>Specialty Tools and Repair Manuals:</u></b>  Successful bidder shall supply any specialty tools, computer software, service manuals, parts manuals, bumper to bumper color coded air, electrical, and hydraulic schematics as per build, with first truck delivered.</p>	<p>YES</p>	
<p><b><u>Liquidated Damages</u></b>  Time is of the essence for delivery. Failure to deliver on or before the date stated by vendor in delivery section is a material breach of the contract. The parties agree that damages for delay would be difficult to calculate. Therefore, liquidated damages in the amount of <b>\$100 per day</b>, beginning the date following the ARO and continuing each day until all equipment, materials, supplies and/or services are delivered to the City, will be withheld from final payment.</p>	<p>YES</p>	

ITB FS 17-137  
ROLL OFF TRUCKS (4)

**BID SECTION**

COST FOR VEHICLE	<u>\$ Input Price Electronically</u>
COST FOR CNG TANK CONVERSION	<u>\$ Input Price Electronically</u>
TIRE TAX	<u>\$ Input Price Electronically</u>
DELIVERY	<u>\$ Input Price Electronically</u>
SALES TAX (10.25%)	<u>\$ Input Price Electronically</u>
TOTAL COST FOR 4 (FOUR)	<u>\$ Input Price Electronically</u>

## Attachment A

### Debarment, Suspension, Ineligibility and Voluntary Exclusion Certification

*Please read Acceptance of Certification and Instructions for Certification before completing*

As a current or potential vendor for the City of Long Beach (City) your firm, through its business relationship with the City, may be the recipient of federal grant funds. As such, the City is required to document that neither your business entity or organization, nor any of your principals are debarred, suspended, ineligible, or have voluntarily been excluded from receiving federal grant funds. Consistent with Executive Order No. 12549 Title 2 CFR Part 180 Subpart C, all potential recipients of federal grant funds are required to comply with the requirements specified below. By submission of proposal/bid/agreement, the undersigned, under penalty of perjury, certifies that the participant, nor any of its principals in the capacity of owner, director, partner, officer, manager, or other person with substantial influence in the development or outcome of a covered transaction, whether or not employed by the participant:

- Are not currently under suspension, debarment, voluntary exclusion, or determination of ineligibility by any Federal department or agency;
- Have not, within a three (3) year period preceding this bid/agreement/proposal, been suspended, debarred, voluntarily excluded or declared ineligible by a federal agency;
- Do not presently have a proposed debarment proceeding pending;
- Have not, within a three (3) year period preceding this bid/agreement/proposal, been indicted or convicted, or had a civil judgment rendered against it by a court of competent jurisdiction in any matter involving fraud or official misconduct;
- Have not, within a three (3) year period preceding this bid/agreement/proposal, had one or more public transactions (Federal, State, or local) terminated for cause or default.

If reorganization, management turnover, or a shift or change of principals' status occurs, written notice must be submitted within 21 days. Subsequent disclosure of unfavorable information will be subject to thorough review and remedial action. Updated versions of this certification may be requested on a routine basis.

Where the potential prospective recipient of Federal assistance funds is unable to certify to any of the statement in this certification, such prospective participant shall attach an explanation to the applicable bid/agreement/proposal.

LOS ANGELES TRUCK CENTERS, LLC dba LOS ANGELES FREIGHTLINER

Business/Contractor/Agency

RON CREIGHTON

FLEET & MUNICIPAL SALES

Name of Authorized Representative

Title of Authorized Representative



AUGUST 29, 2017

Signature of Authorized Representative

Date

r20141001

## **Acceptance of Certification**

1. This bid/agreement/proposal or like document has the potential to be a recipient of Federal funds. In order to be in compliance with Code of Federal Regulations, the City requires this completed form. By signing and submitting this document, the prospective bidder/proposer is providing the certification and acknowledgement as follows:
2. The terms "covered transaction," "debarred," "suspended," "ineligible," "lower tier covered transaction," "participant," "person," "primary covered transaction," "principal," "proposal," and "voluntarily excluded," as used in this clause, have the meanings set out in the Definitions and Coverage sections of rules implementing Executive Order 12549.
3. The certification in this clause is a material representation of fact upon which reliance was placed when this transaction was entered into. If it is later determined that the prospective recipient of Federal assistance funds knowingly rendered an erroneous certification, in addition to other remedies available to the Federal Government, the department or agency with which this transaction originated may pursue available remedies, including suspension and/or debarment.
4. The potential recipient of Federal assistance funds agrees by submitting this bid/agreement/proposal or like document that, should the proposed covered transaction be entered into, it shall not knowingly enter into any lower tier covered transaction with a person who is debarred, suspended, declared ineligible, or voluntarily excluded from participation in this covered transaction, unless authorized by the department or agency with which this transaction originated.

### **Instructions for completing the form, Attachment –Debarment Certification**

1. The City of Long Beach sometimes receives Federal funding on certain purchases/projects. To ensure that the City is in compliance with Federal regulations we require this form to be completed.
2. The City of Long Beach checks the System for Award Management at [www.sam.gov](http://www.sam.gov) to make sure that Consultants who are awarded City contracts and/or purchase orders are not debarred or suspended. Prospective Consultants should perform a search on this website for your company and or persons associated with your business.
3. If your business is in compliance with the conditions in the form, please have the appropriate person complete and sign this form and return with your bid/proposal/agreement.
4. If at anytime, your business or persons associated with your business become debarred or suspended, we require that you inform us of this change in status.
5. If there are any exceptions to the certification, please include an attachment. Exceptions will not necessarily result in denial of award, but will be considered in determining bidder responsibility. For any exception, indicate to whom it applies, initiating agency and dates of action.
6. Note: Providing false information may result in criminal prosecution or administrative sanctions.

***If you have any questions on how to complete this form, please contact the  
Purchasing Division in the City of Long Beach Business Relations Bureau at 562-570-6200***

Rev 12.11.13



City of Long Beach  
Purchasing Division  
333 W Ocean Blvd/7<sup>th</sup> Floor  
Long Beach CA 90802

## ATTACHMENT B

### Reference Information Form

Client/Contractor Name CITY OF TORRANCE

Project Manager/Contact Name DAMIAN SKINNER E-mail DSkinner@TorranceCA.gov Ph. No. 310-781-6900

Address 20500 MADRONA AVENUE TORRANCE, CA. 90503

Project Description BID NO. B2016-46

Project Dates (Start and End) 10/19/2016 Contract Term(s) \_\_\_\_\_ Contract Amount \$248,279.89

Client/Contractor Name CITY OF OXNARD

Project Manager/Contact Name KEN DUNHAM E-mail ken.dunham@ci.oxnard.ca.us Ph. No. 805-247-8920

Address 300 WEST 3rd. STREET OXNARD, CA. 93030

Project Description BID NO. CM-R15-19R - CNG ROLL-OFF REFUSE TRUCK

Project Dates (Start and End) \_\_\_\_\_ Contract Term(s) \_\_\_\_\_ Contract Amount \$733,269.00

Client/Contractor Name CITY OF ONTARIO

Project Manager/Contact Name MICHAEL JOHNSON E-mail mjohnson@ci.ontario.ca.us Ph. No. 909-395-2690

Address 1425 S. BONVIEW AVENUE ONTARIO, CA. 91761

Project Description CNG ROLL-OFF

Project Dates (Start and End) \_\_\_\_\_ Contract Term(s) \_\_\_\_\_ Contract Amount \$765,000.00

Client/Contractor Name CITY OF GLENDALE

Project Manager/Contact Name AFSHIN BOKAEI E-mail ABokaei@Glendaleca.gov Ph. No. (818) 548-2102

Address 141 N. GLENDALE AVENUE, ROOM #346

Project Description BID NO. GLN-400001563 CNG ROLL-OFF

Project Dates (Start and End) \_\_\_\_\_ Contract Term(s) \_\_\_\_\_ Contract Amount \$267,542.16

Client/Contractor Name CITY OF BURBANK

Project Manager/Contact Name ROBERT CRAWFORD E-mail rcrawford@burbankca.gov Ph. No. 818-238-3841

Address 301 R. OLIVE AVENUE BURBANK, CA. 91510

Project Description PORT OF LOS ANGELES BID NO. F-845 (COOPERATIVE PURCHASE)

Project Dates (Start and End) JUNE 2014 Contract Term(s) \_\_\_\_\_ Contract Amount \$226,991.41

Attachment C

**W-9 Request for Taxpayer  
Identification Number and Certification**

[Form must be signed and dated]

**Request for Taxpayer  
 Identification Number and Certification**

Give Form to the requester. Do not send to the IRS.

Print or type See Specific Instructions on page 2.	Name (as shown on your income tax return) <b>LOS ANGELES TRUCK CENTERS, LLC</b>	
	Business name/disregarded entity name, if different from above	
	Check appropriate box for federal tax classification: <input type="checkbox"/> Individual/sole proprietor <input type="checkbox"/> C Corporation <input type="checkbox"/> S Corporation <input type="checkbox"/> Partnership <input type="checkbox"/> Trust/estate <input checked="" type="checkbox"/> Limited liability company. Enter the tax classification (C=C corporation, S=S corporation, P=partnership) ▶ _____ <input type="checkbox"/> Other (see instructions) ▶ _____	Exemptions (see instructions):  Exempt payee code (if any) _____ Exemption from FATCA reporting code (if any) _____
	Address (number, street, and apt. or suite no.) <b>2429 S. PECK ROAD</b>	Requester's name and address (optional)
City, state, and ZIP code <b>WHITTIER, CA, 90601</b>		
List account number(s) here (optional)		

**Part I Taxpayer Identification Number (TIN)**

Enter your TIN in the appropriate box. The TIN provided must match the name given on the "Name" line to avoid backup withholding. For individuals, this is your social security number (SSN). However, for a resident alien, sole proprietor, or disregarded entity, see the Part I Instructions on page 3. For other entities, it is your employer identification number (EIN). If you do not have a number, see *How to get a TIN* on page 3.

<b>Social security number</b>												
<table border="1" style="width:100%; border-collapse: collapse;"> <tr> <td style="width:15%; height: 20px;"> </td> <td style="width:15%; height: 20px;"> </td> <td style="width:15%; height: 20px;"> </td> <td style="width:15%; height: 20px;"> </td> <td style="width:15%; height: 20px;"> </td> <td style="width:15%; height: 20px;"> </td> </tr> <tr> <td style="text-align:center;">-</td> <td style="text-align:center;">-</td> <td style="text-align:center;">-</td> <td style="text-align:center;">-</td> <td style="text-align:center;">-</td> <td style="text-align:center;">-</td> </tr> </table>							-	-	-	-	-	-
-	-	-	-	-	-							
<b>Employer identification number</b>												
<table border="1" style="width:100%; border-collapse: collapse;"> <tr> <td style="width:15%; height: 20px;"> </td> <td style="width:15%; height: 20px;"> </td> <td style="width:15%; height: 20px;"> </td> <td style="width:15%; height: 20px;"> </td> <td style="width:15%; height: 20px;"> </td> <td style="width:15%; height: 20px;"> </td> </tr> </table>												

Note. If the account is in more than one name, see the chart on page 4 for guidelines on whose number to enter.

**Part II Certification**

Under penalties of perjury, I certify that:

- The number shown on this form is my correct taxpayer identification number (or I am waiting for a number to be issued to me), and
- I am not subject to backup withholding because: (a) I am exempt from backup withholding, or (b) I have not been notified by the Internal Revenue Service (IRS) that I am subject to backup withholding as a result of a failure to report all interest or dividends, or (c) the IRS has notified me that I am no longer subject to backup withholding, and
- I am a U.S. citizen or other U.S. person (defined below), and
- The FATCA code(s) entered on this form (if any) indicating that I am exempt from FATCA reporting is correct.

Certification instructions. You must cross out item 2 above if you have been notified by the IRS that you are currently subject to backup withholding because you have failed to report all interest and dividends on your tax return. For real estate transactions, item 2 does not apply. For mortgage interest paid, acquisition or abandonment of secured property, cancellation of debt, contributions to an individual retirement arrangement (IRA), and generally, payments other than interest and dividends, you are not required to sign the certification, but you must provide your correct TIN. See the instructions on page 3.

<b>Sign Here</b>	Signature of U.S. person ▶	Date ▶
------------------	----------------------------	--------

**General Instructions**

Section references are to the Internal Revenue Code unless otherwise noted.

**Future developments.** The IRS has created a page on [irs.gov](http://irs.gov) for information about Form W-9, at [www.irs.gov/w9](http://www.irs.gov/w9). Information about any future developments affecting Form W-9 (such as legislation enacted after we release it) will be posted on that page.

**Purpose of Form**

A person who is required to file an information return with the IRS must obtain your correct taxpayer identification number (TIN) to report, for example, income paid to you, payments made to you in settlement of payment card and third party network transactions, real estate transactions, mortgage interest you paid, acquisition or abandonment of secured property, cancellation of debt, or contributions you made to an IRA.

Use Form W-9 only if you are a U.S. person (including a resident alien), to provide your correct TIN to the person requesting it (the requester) and, when applicable, to:

- Certify that the TIN you are giving is correct (or you are waiting for a number to be issued),
- Certify that you are not subject to backup withholding, or
- Claim exemption from backup withholding if you are a U.S. exempt payee. If applicable, you are also certifying that as a U.S. person, your allocable share of any partnership income from a U.S. trade or business is not subject to the withholding tax on foreign partner's share of effectively connected income, and
- Certify that FATCA code(s) entered on this form (if any) indicating that you are exempt from the FATCA reporting, is correct.

**Note.** If you are a U.S. person and a requester gives you a form other than Form W-9 to request your TIN, you must use the requester's form if it is substantially similar to this Form W-9.

**Definition of a U.S. person.** For federal tax purposes, you are considered a U.S. person if you are:

- An individual who is a U.S. citizen or U.S. resident alien,
- A partnership, corporation, company, or association created or organized in the United States or under the laws of the United States,
- An estate (other than a foreign estate), or
- A domestic trust (as defined in Regulations section 301.7701-7).

**Special rules for partnerships.** Partnerships that conduct a trade or business in the United States are generally required to pay a withholding tax under section 1446 on any foreign partner's share of effectively connected taxable income from such business. Further, in certain cases where a Form W-9 has not been received, the rules under section 1446 require a partnership to presume that a partner is a foreign person, and pay the section 1446 withholding tax. Therefore, if you are a U.S. person that is a partner in a partnership conducting a trade or business in the United States, provide Form W-9 to the partnership to establish your U.S. status and avoid section 1446 withholding on your share of partnership income.

## Attachment D

### **EQUAL BENEFITS ORDINANCE DISCLOSURE**

As a condition of being awarded a contract with the City of Long Beach ("City"), the selected Contractor/Vendor ("Contractor") may be required during the performance of the Contract, to comply with the City's nondiscrimination provisions of the Equal Benefits Ordinance ("EBO") set forth in the Long Beach Municipal Code section 2.73 et seq. The EBO requires that during the performance of the contract, the Contractor shall provide equal benefits to its employees with spouses and employees with domestic partners. Benefits include but are not limited to, health benefits, bereavement leave, family medical leave, membership and membership discounts, moving expenses, retirement benefits and travel benefits. A cash equivalent payment is permitted if an employer has made all reasonable efforts to provide domestic partners with access to benefits but is unable to do so. A situation in which a cash equivalent payment might be used if where the employer has difficulty finding an insurance provider that is willing to provide domestic partner benefits.

The EBO is applicable to the following employers:

- For-profit employers that have a contract with the City for the purchase of goods, services, public works or improvements and other construction projects in the amount of \$100,000 or more
- For-profit entities that generate \$350,000 or more in annual gross receipts leasing City property pursuant to a written agreement for a term exceeding 29 days in any calendar year

Contractors who are subject to the EBO must certify to the City before execution of the contract that they are in compliance with the EBO by completing the EBO Certification Form, attached, or that they have been issued a waiver by the City. Contractors must also allow authorized City representatives access to records so the City can verify compliance with the EBO.

The EBO includes provisions that address difficulties associated with implementing procedures to comply with the EBO. Contractors can delay implementation of procedures to comply with the EBO in the following circumstances:

- 1) By the first effective date after the first open enrollment process following the contract start date, not to exceed two years, if the Contractor/vendor submits evidence of taking reasonable measures to comply with the EBO; or
- 2) At such time that the administrative steps can be taken to incorporate nondiscrimination in benefits in the Contractor/vendor's infrastructure, not to exceed three months; or
- 3) Upon expiration of the contractor's current collective bargaining agreement(s).

Compliance with the EBO



If a contractor has not received a waiver from complying with the EBO and the timeframe within which it can delay implementation has expired but it has failed to comply with the EBO, the Contractor may be deemed to be in material breach of the Contract. In the event of a material breach, the City may cancel, terminate or suspend the City agreement, in whole or in part. The City also may deem the Contractor an irresponsible bidder and disqualify the Contractor from contracting with the City for a period of three years. In addition, the City may assess liquidated damages against the Contractor which may be deducted from money otherwise due the Contractor. The City may also pursue any other remedies available at law or in equity.

By my signature below, I acknowledge that the Contractor understands that to the extent it is subject to the provisions of the Long Beach Municipal Code section 2.73, the Contractor shall comply with this provision.

Printed Name: RON CREIGHTON Title: FLEET & MUNICIPAL SALES

Signature:  Date: AUGUST 29, 2017

Business Entity Name: LOS ANGELES TRUCK CENTERS, LLC dba LOS ANGELES FREIGHTLINER

## EQUAL BENEFITS ORDINANCE CERTIFICATION OF COMPLIANCE

### Section 1. CONTRACTOR/VENDOR INFORMATION

LOS ANELES TRUCK CENTERS, LLC dba

Name: LOS ANGELES FREGHTLINER Federal Tax ID No ██████████  
Address: 2429 S. PECK ROAD  
City: WHITTIER, State: CA ZIP: 90601  
Contact Person: RON CREIGHTON Telephone: (909) 510-4406  
Email: rcreighton@lafreightliner.com Fax: (562) 447-1544

### Section 2. COMPLIANCE QUESTIONS

- A. The EBO is inapplicable to this Contract because the Contractor/Vendor has no employees.  Yes  No
- B. Does your company provide (or make available at the employees' expense) any employee benefits?  Yes  No  
(If "yes," proceed to Question C. If "no," proceed to section 5, as the EBO does not apply to you.)
- C. Does your company provide (or make available at the employees' expense) any benefits to the spouse of an employee?  
 Yes  No
- D. Does your company provide (or make available at the employees' expense) any benefits to the domestic partner of an employee?  
 Yes  No (If you answered "no" to both questions C and D, proceed to section 5, as the EBO is not applicable to this contract. If you answered "yes" to both Questions C and D, please continue to Question E. If you answered "yes" to Question C and "no" to Question D, please continue to section 3.)
- E. Are the benefits that are available to the spouse of an employee identical to the benefits that are available to the domestic partner of an employee?  
 Yes  No  
(If "yes," proceed to section 4, as you are in compliance with the EBO. If "no," continue to section 3.)

Section 3. PROVISIONAL COMPLIANCE

- A. Contractor/vendor is not in compliance with the EBO now but will comply by the following date:

\_\_\_\_\_ By the first effective date after the first open enrollment process following the contract start date, not to exceed two years, if the Contractor/vendor submits evidence of taking reasonable measures to comply with the EBO; or

\_\_\_\_\_ At such time that the administrative steps can be taken to incorporate nondiscrimination in benefits in the Contractor/vendor's infrastructure, not to exceed three months; or

\_\_\_\_\_ Upon expiration of the contractor's current collective bargaining agreement(s).

- B. If you have taken all reasonable measures to comply with the EBO but are unable to do so, do you agree to provide employees with a cash equivalent? (The cash equivalent is the amount of money your company pays for spousal benefits that are unavailable for domestic partners.)

\_\_\_\_ Yes \_\_\_\_ No

Section 4. REQUIRED DOCUMENTATION

At time of issuance of purchase order or contract award, you may be required by the City to provide documentation (copy of employee handbook, eligibility statement from your plans, insurance provider statement, etc.) to verify that you do not discriminate in the provision of benefits.

Section 5. CERTIFICATION

I declare under penalty of perjury under the laws of the State of California that the foregoing is true and correct and that I am authorized to bind this entity contractually. By signing this certification, I further agree to comply with all additional obligations of the Equal Benefits Ordinance that are set forth in the Long Beach Municipal Code and in the terms of the contract of purchase order with the City.

Executed this 29 day of AUGUST, 2017, at WHITTIER, CA.

Name RON CREIGHTON

Signature 

Title FLEET & MUNICIPAL SALES

Federal Tax ID No. 



City of Long Beach  
Purchasing Division  
333 w. Ocean Blvd 7<sup>th</sup> Floor  
Long Beach, CA 90802

## ATTACHMENT E

### INSURANCE REQUIREMENTS

Contractor shall submit proof of insurability from an insurance company with an: 8 rating {as specified in City AR 8-27} from AM Best Company with bid. Failure to submit this proof will disqualify the bid.

- Successful bidder shall obtain and maintain at its expense until completion of performance and acceptance by the City, from an insurer:
  - Admitted (Licensed) in the State of California with a current financial responsibility rating of an Excellent or better and a current financial size category (FSC) of V (Capital Surplus and Conditional Surplus Funds of greater than \$10 million) or greater rating as reported by AM Best Company or equivalent, unless waived in writing by the City's Risk Manager, or
  - Non-admitted in the State of California with a current financial responsibility rating of an Excellent or better and a current financial size category (FSC) of VIII (Capital Surplus Funds or greater than \$100 million) or greater rating as reported by AM Best Company or equivalent, unless waived in writing by City's Risk Manager.
  - Comprehensive General Liability naming City, its Officials, Employees, and Agents as additional insureds for injury to or death of persons or damage to or loss of property arising from or connected to vendor's performance here-under \$1,000,000 combined single limit for each occurrence and \$2,000,000 General Aggregate.
  - Automobile Liability: \$500,000 combined single limit per accident for bodily injury and property damage covering owned, non-owned and hired vehicles.
  - Worker's Compensation: As required by California Labor Code.
- Self-insurance of self-insured retention must be approved in writing by City and protect City in same manner and extent as if policies had not contained retention. Each policy must be endorsed to state that coverage shall not be cancelled by either party or reduced in coverage except after 30 days prior written notice to City. Vendor must furnish to City before performance certificates of insurance and original endorsements, with the original signature of one authorized by the insurer to bind coverage on its behalf, for approval as to sufficiency and form. This insurance shall not be deemed to limit vendor's liability hereunder.
- Contractor shall maintain at its expense, until completion of performance and acceptance by City, from an insurer:
  - Admitted (licensed) in the State of California with a current financial responsibility rating of A (Excellent) or better and a current financial size category (FSC) of V (capital surplus



City of Long Beach  
Purchasing Division  
333 w. Ocean Blvd 7<sup>th</sup> Floor  
Long Beach, CA 90802

- and conditional surplus funds of greater than \$10 million) or greater rating as reported by A.M. Best Company or equivalent, unless waived in writing by City's Risk Manager, or
- Non-admitted in the State of California with a current financial responsibility rating of A (Excellent) or better and a current financial size category (FSC) of VIII (capital surplus and conditional surplus funds of greater than \$100 million) or greater rating as reported by A.M. Best Company or equivalent, unless waived in writing by the City's Risk Manager.
  - All coverages for Subcontractors shall be subject to the requirements stated herein and shall be maintained at no expense to the City.
  - Contractor shall furnish the City with certificates of insurance and original endorsements providing coverage as required above. The certificates and endorsements for each insurance policy are to be signed by a person authorized by that insurer to bind coverage on its behalf.
  - Before any of Contractor's or Subcontractor's employees shall do any work on the City's property, Contractor shall furnish the City with the required certificates evidencing that such insurance is being maintained. Such certificates shall specify the date when such insurance expires. Such insurance shall be maintained until after the Work under the Contract has been completed and accepted.
  - Such insurance as required herein or in any other documents to be considered a part hereof shall not be deemed to limit Contractor's liability under this Contract.
  - Contractor shall defend, indemnify and hold harmless the City, its officials and employees from and against any and all liability for claims for bodily injury and property damage arising out of negligent acts, omissions or errors of any employee of Contractor at the Site.
  - Contractor shall list the name and location of the place of business of each Subcontractor who will perform work, labor or services for Contractor, or who specially fabricates and installs a portion of the Work or improvement in an amount in excess of one-half of one percent of Contractor's total contract cost. The Subcontractor list shall be submitted with Contractor's Bid.

By submitting a signature below, Bidder promises that insurance requirements can be provided as requested.

Printed Name:	<u>RON CREIGHTON</u>	Title:	<u>FLEET &amp; MUNICIPAL SALES</u>
Signature:	<u></u>	Date:	<u>AUGUST 29, 2017</u>



# XPEDITOR

ACX 6X4 TYPICAL  
 CUMMINS ISL ENGINE  
 ALLISON 4500 TRANSMISSION  
 MERITOR 20K STEER AXLE  
 MERITOR RT46 REAR AXLE  
 HENDRICKSON HMX 46K REAR SUSPENSION  
 207" WHEELBASE  
 62" OVERHANG  
 ALL DIMENSIONS IN INCHES

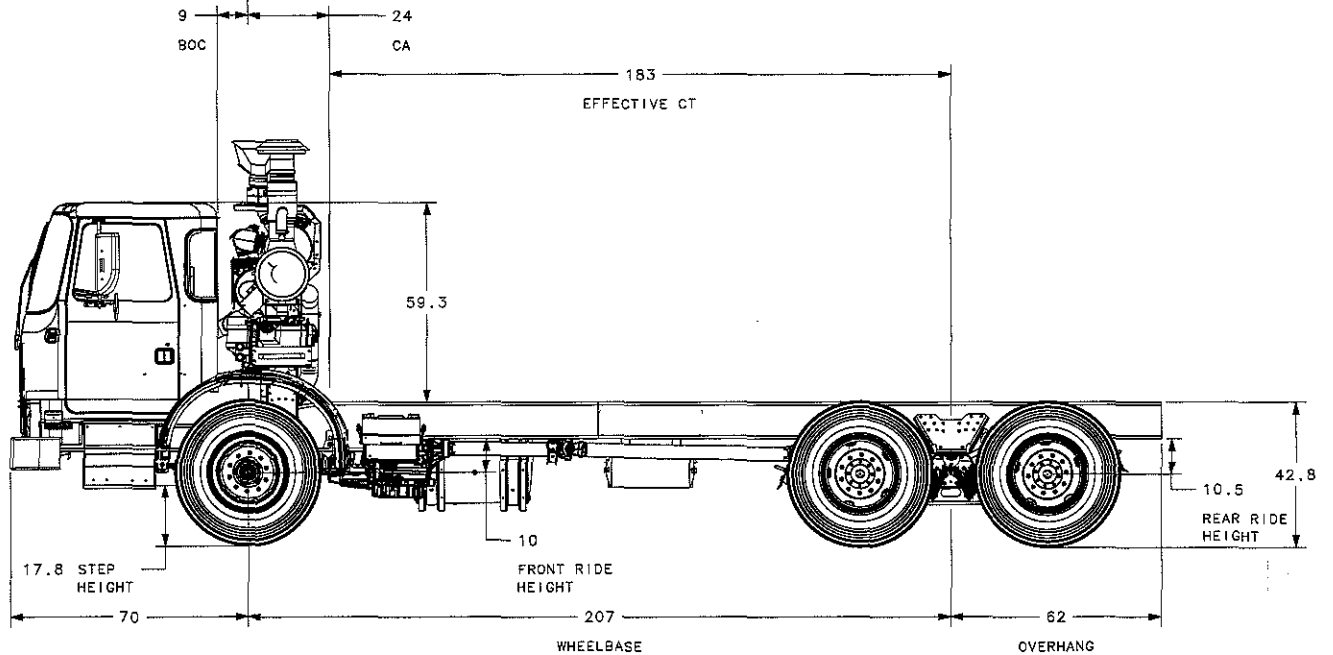
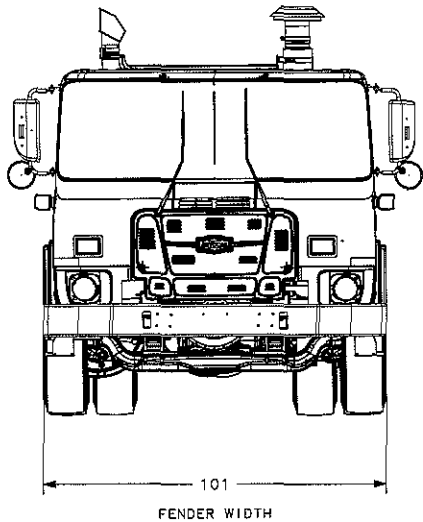
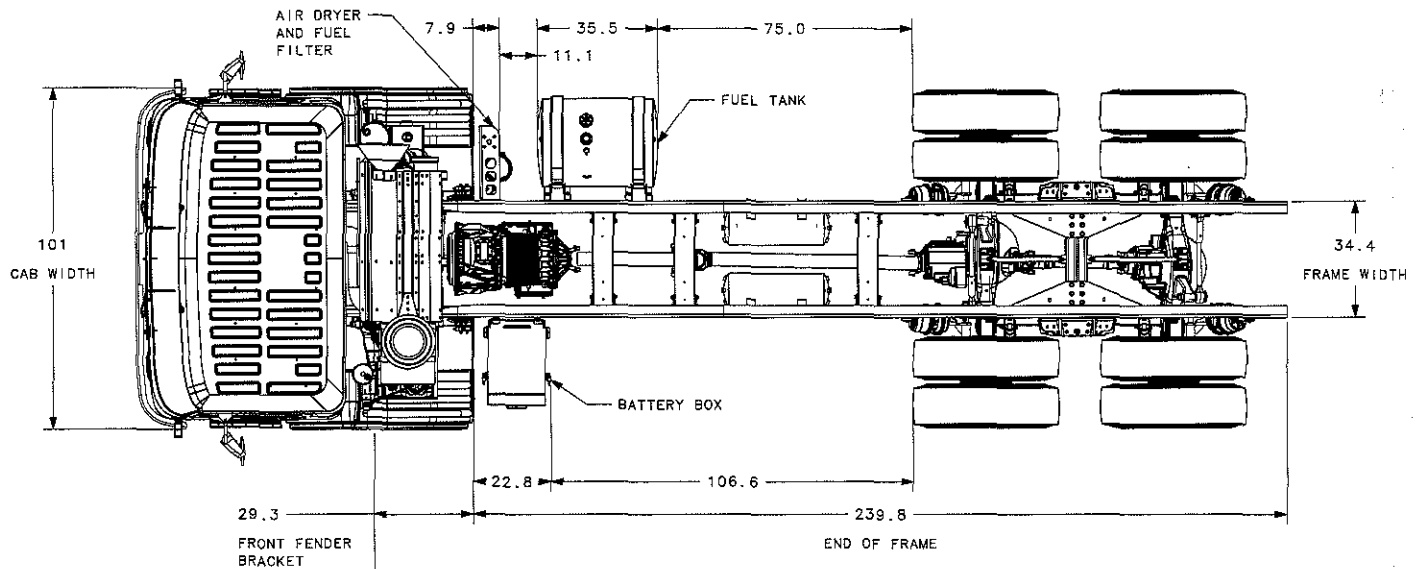

## FRAME WIDTHS FOR ALL MODELS

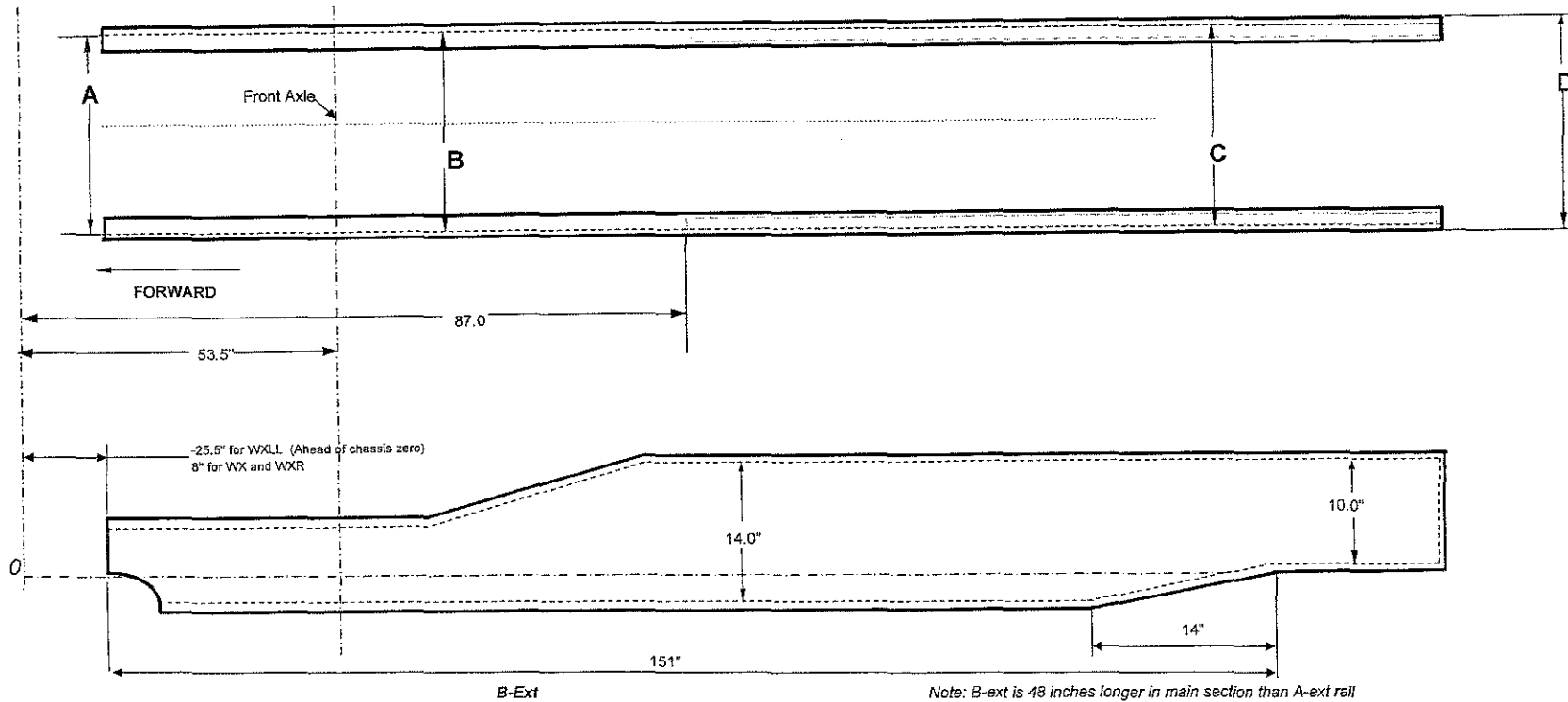

## Xpeditor

FRAME RAIL SIZE	INNER REINF	Section Modulus		RBM		A		B		C		D		Weight/Foot of Rail (1)	
		Main	Rear	Main	Rear	(inches)	(mm)	(inches)	(mm)	(inches)	(mm)	(inches)	(mm)	(lbs.)	(kg)
10.76" x 3.50" x 0.375"	NONE	29.41	18.96	3,529,000	2,275,000	33.62	853.95	33.62	853.95	33.62	853.95	34.37	873.00	43.2	19.6
10.76" x 3.50" x 0.375"	.25" x 10"	35.17	28.92	4,220,000	3,470,000	33.62	853.95	33.62	853.95	33.12	841.25	34.37	873.00	69.6	31.6

NOTES: (1) Divide by 2 for weight per foot of frame for each individual rail (rear section)  
Yield strength of steel rails is 120,000 psi minimum

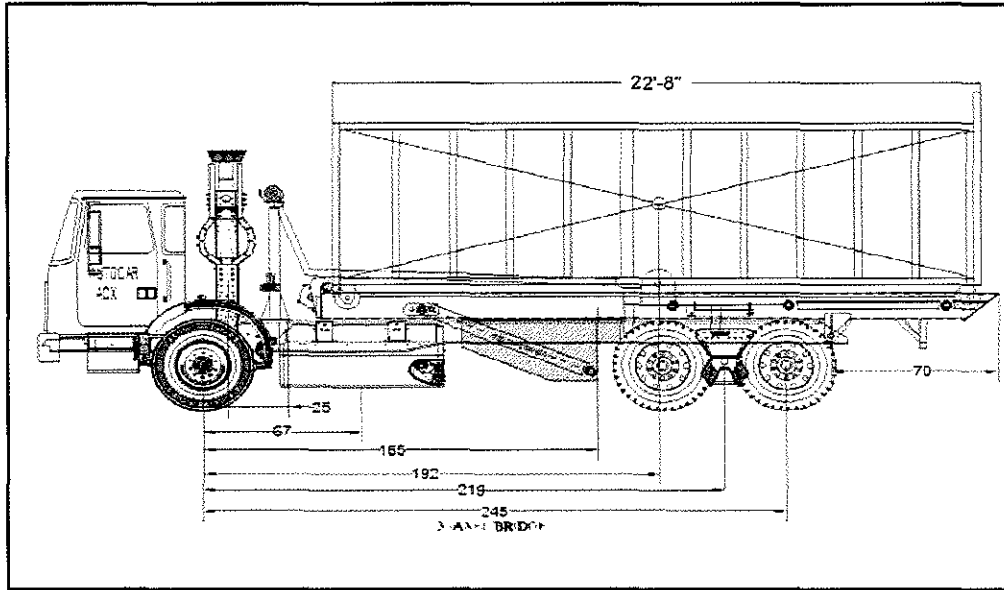

ALL WEIGHTS AND PAYLOADS ARE ESTIMATED AND COULD VARY + OR - 3%

## Weight Distribution

CITY OF LONG BEACH  
 AUTOCAR ACX  
 Roll-off  
 CNG 40 DGE

Body Weight LBS	
BRIDGE LAW	RollOff
51,000	6,500

Fuel Tanks		
	CNG	
	Empty	Full
LBS	1,035	1,395
Mid Route Weight LBS	1,215	

Chassis Builder	AUTOCAR	Axels	3
Body Type	RollOff		
Chassis Length	219	Length	
Tank Location	67		
Body CG Location	165		
Refuse Load	192		

Additional LBS	Options
TARP SYSTEM	800

	Front axle	Pusher axle	Tandem	Single	Tag axel	Total
LBS Max	20,000		34,000	0		
Chassis	10,262	0	5,986	0	0	16,248
Tools/Driver	420	0	45	0	0	375
Fuel/Tank	843	0	372	0	0	1,215
Sub Total Chassis	11,525	0	6,313	0	0	17,838
Body Weight	1,603	0	4,897	0	0	6,500
TARP	511	0	289	0	0	800
Tare	13,639	0	11,499	0	0	25,138
Load	3,144	0	22,356	0	0	25,500
Gross Weight	16,783	0	33,855	0	0	50,638

Refuse weight LBS	<b>PAYLOAD</b>
	25,500









# AMROCNG-H-24

## STANDARD BODY SPECIFICATIONS

### Hoist Type

60,000lb Cable Reeving  
120,000lb Cylinder Capacity  
30,000lb Line Pull

### Box Capacity

Up To 24ft

### Rail Dimensions

12 x 4 x 3/8 x 23' 6" Rectangular Tubing  
ASTM A500 steel-Grade B (50,000 yield min)

### Rail Type

Outside Rail 34" (Standard)

### Hoist Cylinders

5 1/2" Bore, 62 5/8 Stroke, 3" Rod

### Reeving Cylinders

6" Bore, 97 1/2" Stroke, 3" Rod

### Pulleys

9" Diameter With Bronze Bushings On 2 1/4" Shafts

### Cable

7/8" x 75', 6 x 25 IWRC, EIPS. Rated At 80,000lbs

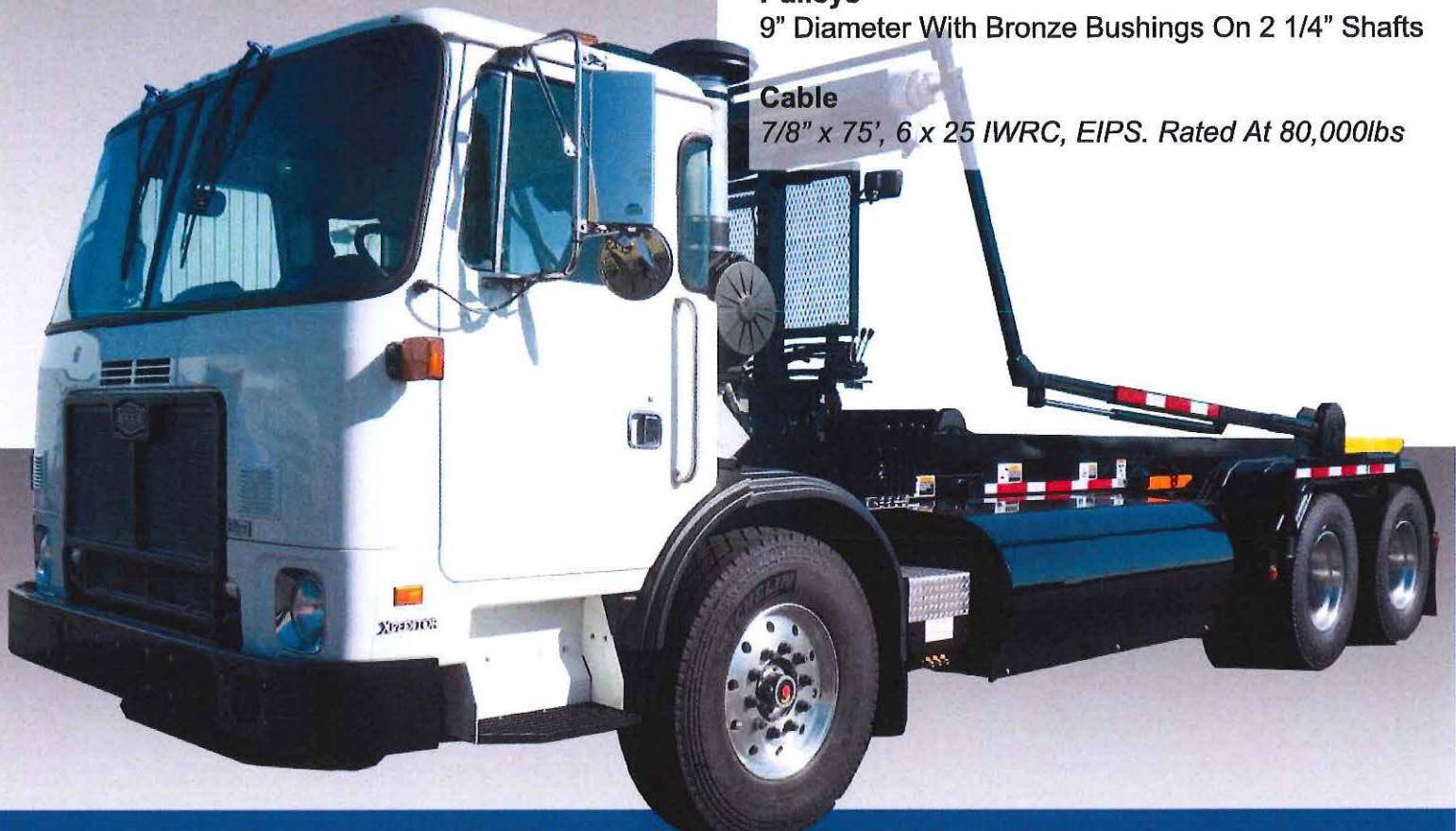

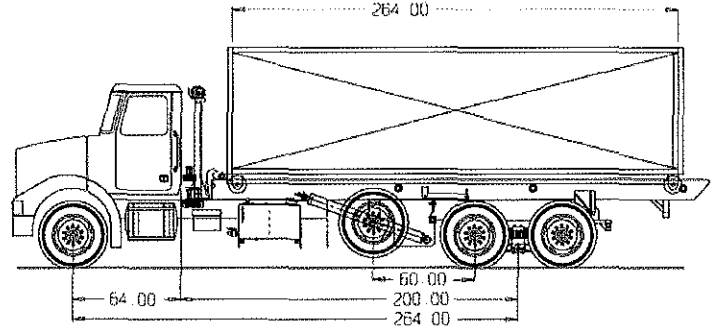
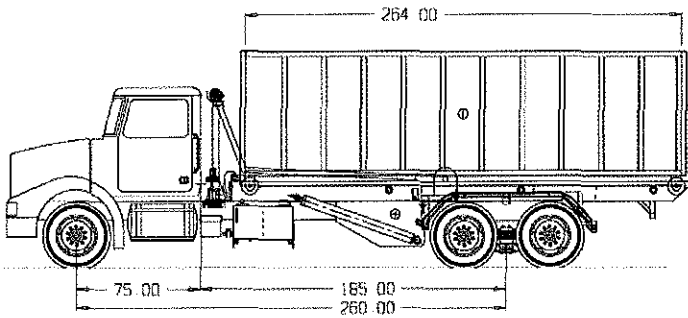

### CHASSIS RECOMMENDATIONS

185" Clear Frame (Without Tarping System)  
 190" Clear Frame (With Tarping System)  
 GAVWR - Front Axle 16,000lbs Minimum  
 Frame - Heavy Duty  
 Radiator - If Front Pump Is Desired Radiator Must  
 Be Modified By Chassis Manufacturer  
 Muffler - Vertical Exhaust With Guard And Rain  
 Cap Or Horizontal

### ROLL OFF SPECIFICATIONS

#### HOIST TYPE

60,000lb Reeving  
 60,000lb Winch\*  
 Inside Frame Hoist  
 (\*optional)

#### RATED CAPACITY

120,000lb Cylinder Capacity, 30,000lb Line Pull

#### CONTAINER CAPACITY

Up To 24'

#### RAIL DIMENSIONS

12 X 4 X 3/8" X 23' 6" Rect. Tubing\*  
 10 X 4 X 3/8" X 23' 6" Rect. Tubing\*  
 8 X 4 X 1/2" X 23' 6" Rect. Tubing\*  
 \*ASTM A500 steel-Grade B (50,000 yield min)

#### RAIL TYPES

Outside Rail (Standard 34")  
 Inside\*  
 Inside/Outside\*  
 "Universal" Top Channel\*  
 (\*optional)

#### CABLE PULLEY

9" Diameter Grooved for 3/4 or 1" Cable  
 Bronze Bushing

#### ROLLERS (OUTSIDE RAIL)

(3) 4 1/2 X 2 1/2 X 4 With Zerk Fitting

#### CABLE

7/8" x 75', 6 x 25 IWRC, EIPS.

#### SUB-FRAME / FISH PLATE

1/4" X 24 X 60

#### HOIST CYLINDER MOUNTS

Lower Shaft 3 1/2"  
 Upper Shaft 2 1/2"

#### HOIST ANGLE

42 - 46 Degrees (Variable)

#### HINGE PIN

2" X 46" Cold Roll Solid Bar

### CONTROLS

Exterior - Manual Levers On Control Valve  
 Interior - Pneumatic or Cable\*  
 (\*optional)

### HOIST CYLINDERS

(2) Single Stage, Double Acting  
 Length - 77 1/2"  
 Bore - 5 1/2"  
 Stroke - 62 5/8"  
 Rod - 3" Chrome

### REEVING CYLINDERS

Single Stage, Double Acting  
 Length 97 1/2"  
 Bore - 6"  
 Stroke - 83 5/8"  
 Rod - 3"

### CONTROL VALVE

Commercial VA35

### HYDRAULIC TANK

40gal Capacity With Sight & Temp Gauge

### POWER SOURCE

Transmission Mounted - Air Shift  
 Transmission Mounted - Hot Shift  
 Front Direct Drive  
 Gear or Vane Pump

### FENDERS

Minimizer - Full Tandem\*  
 Stainless Steel Polished - Full Tandem\*  
 Polished Aluminum Smooth - Full Tandem\*  
 Stainless Steel Polished - 1/4"  
 More Available Upon Request  
 (\*optional)

### HITCH

Pull Trailer - Premier Model 470 Air 90,000lb\*  
 Pup Trailer - Premier Model 470 Air 90,000lb\*  
 Frame or Rail Mounted With Hydraulics  
 Requires Factory Installed Trailer Protection Valve  
 (\*optional)

### TARPING SYSTEM

Full Auto Tarp\*  
 Spring Arm System\*  
 Pull Tarp System\*  
 Multiple Manufacturers Available  
 (\*optional)

### CAB PROTECTION

Steel Mesh Screen Behind Cab\*  
 (\*optional)

### ELECTRICAL

Standard Incandescent Lighting  
 LED Lighting Package\*  
 Work Lights Back Of Cab\*  
 Work Lights On Rear Light Bar\*  
 Body Electrical - Harnessed  
 (\*optional)

### TOOL BOX

Steel Lockable 36"\*  
 Aluminum Lockable 36"\*  
 (\*optional)

### ICC BAR

Fixed - Standard  
 Manual Moveable With Lock Pin\*  
 Hydraulic Automatic\*  
 (\*optional)

### MISCELLANEOUS OPTIONS

"Stinger" Extendable Rails  
 Angle Iron Between Rollers  
 Additional Rollers  
 "Wet Line"  
 Tie Down Winches

### ESTIMATED BODY WEIGHT

6,900lbs (Not Including Options)

### SYSTEM OPERATING PRESSURE

1800psi



City of Long Beach  
Standard Warranty

AMREP Inc. warrants the equipment covered by this limited warranty to be free from defects in material and workmanship under normal use, when proper service and maintenance as described in its operation and maintenance manuals are performed, for a period of 12 months from the date equipment is placed in service by the first purchaser.

This limited warranty is extended to the original user only and our obligation is limited to repairing or exchanging any part of the equipment, but not a complete packer body, provided that, in our judgment, the part is defective. Such components or parts thereof shall be repaired or replaced *without cost* to the first purchaser for parts, labor, and transportation.

This warranty is void on any AMREP equipment which, in our opinion shows signs of having been subjected to abuse or misuse, negligence or accident, or having been operated beyond rated capacity, or equipment that has been repaired, altered, or modified by anyone other than AMREP or persons expressly authorized by AMREP.

AMREP reserves the right to at any time, make changes in the design, material, and specifications of the equipment and accessories thereof, without thereby becoming obligated to make similar changes in such equipment or accessories previously manufactured.

AMREP does not assume any liability for loss profits, product, time, or any other direct, indirect or consequential losses, damages or delays. Other than extension of the warranty under AMREP's extended warranty program, no employee or representative is authorized to change this warranty in any or grant any other warranty.

Extended Warranty:

Hydraulic Cylinders 5 Years

Hydraulic Pump 2 Years

**BODY SERIAL NUMBER:** \_\_\_\_\_

**DATE:** \_\_\_\_\_

**Bid Results**

**Bidder Details**

**Vendor Name** Los Angeles Truck Centers, LLC  
**Address** 2429 S. Peck Road  
 Whittier, CA 90601  
 United States  
**Responsee** RON CREIGHTON  
**Responsee Title** FLEET & MUNICIPAL SALES  
**Phone** 909-510-4406 Ext.  
**Email** rcreighton@lafreightliner.com  
**Vendor Type** NONE

**Bid Detail**

**Bid Format** Electronic  
**Submitted** August 31, 2017 12:10:40 AM (Pacific)  
**Delivery Method**  
**Bid Responsive**  
**Bid Status** Submitted  
**Confirmation #** 114898  
**Ranking** 0

**Responsee Comment**

PRIME BID

**Buyer Comment**

**Attachments**

File Title	File Name	File Type
ITB FS 17-137 ACX64	ITB FS 17-137 Roll Off Trucks (4) ACX .pdf	Response File

**Line Items**

Type	Item Code	UOM	Qty	Unit Price	Line Total	Discount	Comment
<b>Discount Terms</b> no discount							
<b>Vehicles</b>							
1	Roll Off Trucks	EA	4	\$213,814.8900	\$855,259.5600	\$855,259.5600	SEE PGS. 4 & 5 FOR OPTION DISCOUNTS & GRANT OPPORTUNITY
				<b>Subtotal</b>	<b>\$855,259.5600</b>	<b>\$855,259.5600</b>	
<b>Equipment</b>							
2	CNG Fuel Tank Conversion	EA	4	\$26,000.0000	\$104,000.0000	\$104,000.0000	DUAL 40 DGE
				<b>Subtotal</b>	<b>\$104,000.0000</b>	<b>\$104,000.0000</b>	
<b>Fees</b>							
3	Tire Tax (per vehicle)	LT	4	\$17.5000	\$70.0000	\$70.0000	10 TIRES
4	Delivery - nontaxable (per vehicle)	LT	4	0	0	0	DELIVERY INCLUDED

HEAVY DUTY CNG ROLL OFF TRUCKS QTY 4 (ITB FS 17-137), bidding on September 5, 2017 11:00 AM (Pacific)

Printed 10/30/2017

**Bid Results**

Type	Item Code	UOM	Qty	Unit Price	Line Total	Discount	Comment
5	Sales Tax at 10.25% (per vehicle)	LT	4	\$24,582.8200	\$98,331.2800	\$98,331.2800	
				<b>Subtotal</b>	<b>\$98,401.2800</b>	<b>\$98,401.2800</b>	
				<b>Total</b>	<b>\$1,057,660.8400</b>	<b>\$1,057,660.8400</b>	