



CITY OF LONG BEACH

DEPARTMENT OF PUBLIC WORKS

333 WEST OCEAN BOULEVARD • LONG BEACH, CA 90802 • (562) 570-6383 • FAX (562) 570-6012

December 5, 2017

HONORABLE MAYOR AND CITY COUNCIL
City of Long Beach
California

RECOMMENDATION:

Authorize the City Manager, or designee, to execute a Public Walkways Occupancy Permit for sidewalk dining at Cheese Addiction, located at 4236 Atlantic Avenue. (District 8)

DISCUSSION

The operator of Cheese Addiction, located at 4236 Atlantic Avenue, requests a permit to temporarily occupy part of the adjoining sidewalk for the purpose of sidewalk dining. The proposed permit area and the list of furnishings to be placed in the permit area are shown on Exhibit A. Approval of this permit is based on the conditions and standards of Chapter 14.14 of the Long Beach Municipal Code, which describes temporary uses of public right-of-way.

The current width of the sidewalk at this location is 12 feet. A minimum clearance of 6 feet along the sidewalk adjacent to the permit area will be maintained to provide for acceptable sidewalk clearances adjacent to the proposed permit area.

This matter was reviewed by the Department of Development Services Building and Safety Bureau on November 2, 2017, by Deputy City Attorney Linda T. Vu on October 31, 2017, and by Budget Analysis Officer Julissa José-Murray on November 7, 2017.

TIMING CONSIDERATIONS

City Council action on this matter is not time critical.

FISCAL IMPACT

A permit processing fee of \$313 was deposited in the General Fund (GF) in the Public Works Department (PW), and a security deposit of \$295 was collected to ensure sidewalk repairs upon permit termination. Approval of this recommendation will provide continued support to the local economy.

SUGGESTED ACTION:

Approve recommendation.

Respectfully submitted,

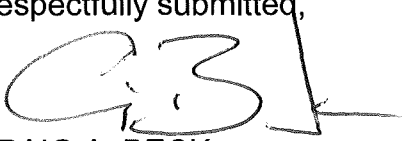

CRAIG A. BECK
DIRECTOR OF PUBLIC WORKS

CB:SC:EL:JH:BP:CB:LA

APPROVED:



PATRICK H. WEST
CITY MANAGER

ATTACHMENT: - EXHIBIT A: SKETCH & LIST OF FURNISHINGS

VICINITY MAP

NO SCALE



ATLANTIC AVE

CARTAGENA ST

CHEESE ADDICTION

ATLANTIC

AVE

(E) BIKE RACK(S) TO BE RELOCATED OR REMOVED AS REQUIRED

(E) STREET TREE AND STREET TREE GRATE

CURB FACE

PEDESTRIAN ACCESS

PEDESTRIAN ACCESS KEEP CLEAR - NO OBSTRUCTIONS

PROPERTY LINE

BARRICADE

(E) SIDEWALK

DOOR ENTRANCE AREA KEEP CLEAR NO OBSTRUCTIONS

(P) PROPOSED SIDEWALK DINING PERMIT AREA

PRIVATE PROPERTY

PROPERTY LINE

CHEESE ADDICTION
4236 ATLANTIC AVE

PROPERTY LINE



SHOWS AREA OF PERMIT

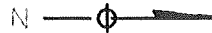

CITY OF LONG BEACH - CALIFORNIA
DEPARTMENT OF PUBLIC WORKS, ENGINEERING BUREAU

PUBLIC WALKWAYS OCCUPANCY

PERMIT
CHEESE ADDICTION
4236 ATLANTIC AVE

List of Approved Furnishings and Accessories
(Attachment to Public Walkways Occupancy Permit for Sidewalk Dining Purposes)

Restaurant: CHEESE ADDICTION LLC Permittee: CHEESE ADDICTION LLC
Address: 4236 ATLANTIC AVE
LONG BEACH CA 90807 Telephone: 562 881 6679

Tables number: 1 - ONE - UNO

Chairs number: 3 - THREE - TRES

Umbrella(s) height & number: 1 - ONE - UNO @ 7 FEET - 84" - 213 CM
- . 213 METER

Heater(s) height & number: NONE

Menu board
note: maximum height of 5 ft 6 in, maximum width of 2 ft & none permitted in the coastal zone N/A

Waiter station size: NONE

Planters for trees or other greenscaping describe: NONE

Other: RAILINGS - SEE SCHEMATICS PROVIDED

We intend to make occasional use of the permit area for live or recorded entertainment (Note: A separate entertainment permit is required).

The following are prohibited:

- canopies (ground supported)
- television monitors

Permittee signature: GIANNI ALRANDESE

Date: 11-1-2017

Print name here: GIANNI ALRANDESE

This list of furnishings and accessories is effective only when attached to a completed Public Walkways Occupancy Permit.

Existing Concrete Base

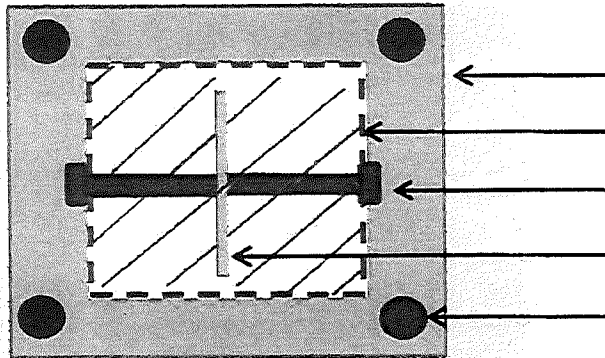

1/4" x 6" x 6" Stainless steel Base Plate

4" x 4" x 36" wooden post

2 (two) 4" Nut and Bolts - top and bottom

Center pillar - 3.5" (W) x 6" (H) - welded to base plate

Expanding Concrete anchor bolts x 4

Top View

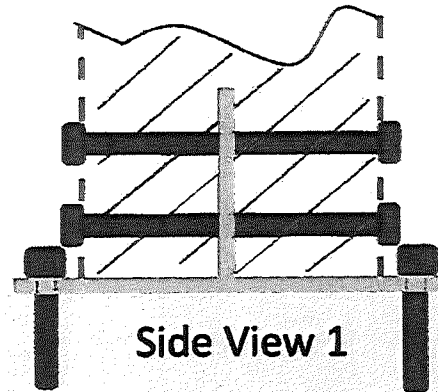

Side View 1

Existing Concrete Base

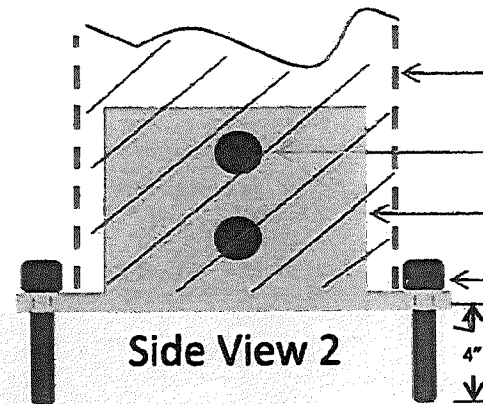

4" x 4" x 36" wooden post

4" Nut and Bolts

Center pillar - 3.5" (W) x 6" (H)
Welded to base plate

Expanding Concrete anchors & bolts

4"
4"

Side View 2

Existing Concrete Base

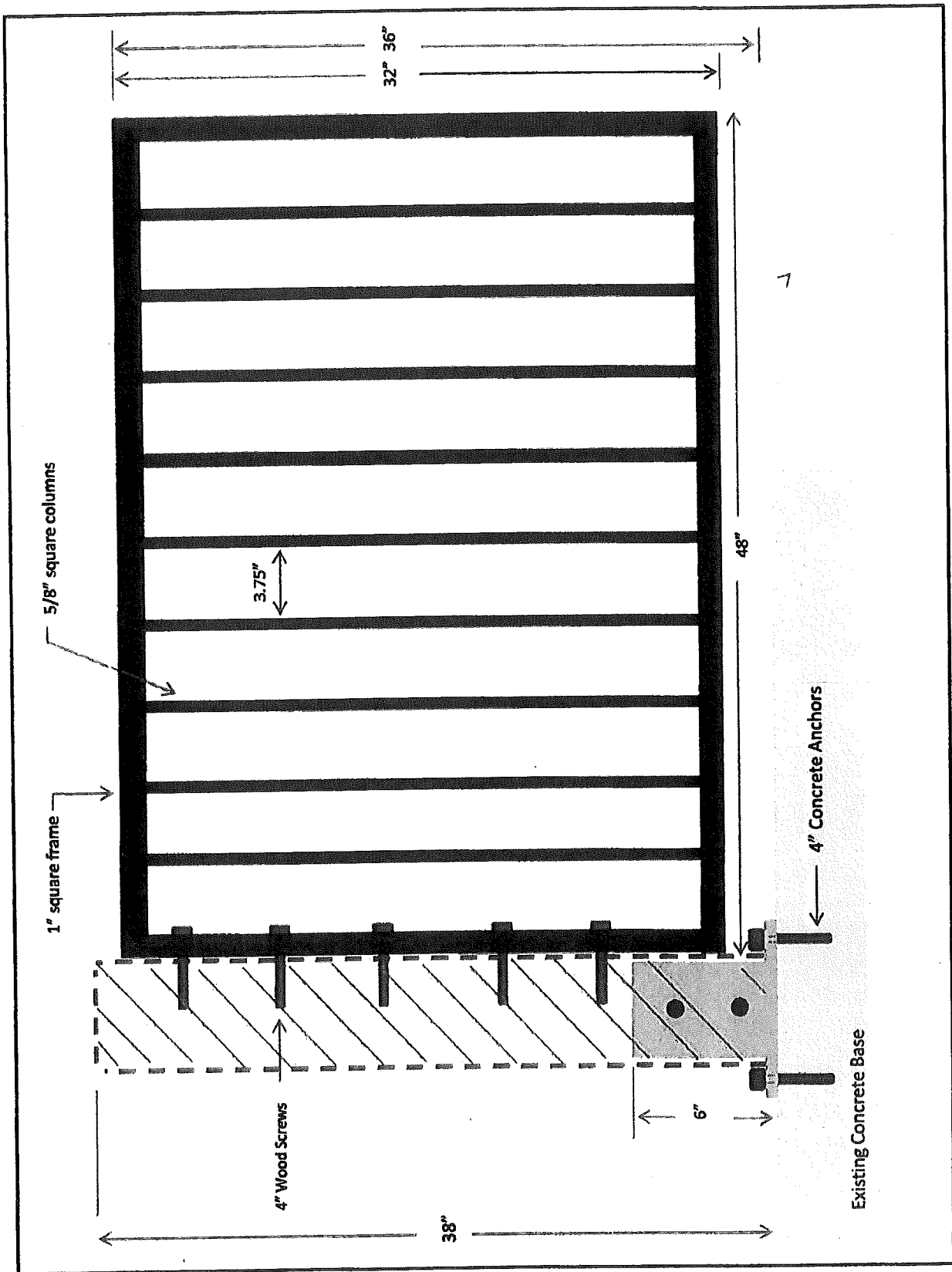

EXHIBIT A
PAGE 4 OF 4