

OFFICE OF THE CITY ATTORNEY
CHARLES PARKIN, City Attorney
333 West Ocean Boulevard, 11th Floor
Long Beach, CA 90802-4664

1
2
3
4
5
6
7
8
9
10
11
12
13
14
15
16
17
18
19
20
21
22
23
24
25
26
27
28

COOPERATIVE AGREEMENT
IMPROVEMENT OF ARTESIA BOULEVARD BETWEEN
HARBOR AVENUE AND BUTLER AVENUE
33791

THIS AGREEMENT is made and entered, in duplicate, as of 1-12-15,
~~2014~~ for reference purposes only, pursuant to a minute order of the City Council of the
City of Long Beach at its meeting held July 22, 2014, by and among the CITY OF LONG
BEACH and the CITY OF COMPTON.

WHEREAS, Artesia Boulevard is a divided arterial highway within the cities
of Long Beach and Compton that requires pavement improvements and pavement
resurfacing between the intersections of Harbor Avenue and Butler Avenue; and

WHEREAS, the City of Long Beach retained GHD, Inc., to prepare
construction plans and specifications, and engineering cost estimates for the required
pavement improvements and pavement resurfacing that identify the jurisdictional
boundary of the cities of Long Beach and Compton and the specific work within each city;
and

WHEREAS, the work to be done can be more efficiently done concurrently
along and across the jurisdictional boundary of these two cities; and

WHEREAS, the parties have identified the work to be done on Artesia
Boulevard, from the intersection of Artesia Boulevard and Harbor Avenue to Gale Avenue
(the "Project"), that includes work within both cities; and

WHEREAS, a cost estimate for the design, construction, construction
engineering and inspection and project admin/management/etc. of the work within the
City of Compton has been prepared by the City of Long Beach as part of its consultant's
design services that was reviewed and is agreeable to the parties; and

WHEREAS, the parties have secured funding for design, construction,
construction engineering and inspection and project admin/management/etc. of the
Project; and

1 WHEREAS, the parties desire to enter into this Cooperative Agreement for
2 the purpose of setting forth their respective roles and responsibilities in order to expedite
3 the Project;

4 NOW, THEREFORE, in consideration of the mutual terms and conditions in
5 this Agreement, the parties agree as follows:

6 1. SCOPE OF WORK. The Project consists of the approved scope of
7 work identified on the reduced plans dated December 10, 2013, attached hereto as
8 Exhibit "A." Any changes to Exhibit "A" requested by the City of Compton must be made
9 in writing by its Director of Public Works and approved in advance by the City of Long
10 Beach Director of Public Works prior to the commencement of work.

11 2. PROJECT BUDGET. The final cost estimate for the Project is
12 identified as One Million One Hundred Sixty-One Thousand Seven Hundred Fifty-Nine
13 Dollars (\$1,161,759.00) on the PROJECT BUDGET, attached hereto as Exhibit "B." The
14 parties agree that the Project Budget allocates One Hundred Thirty-One Thousand Three
15 Hundred Thirty-Six Dollars (\$131,336) from the City of Compton and One Million Thirty
16 Thousand Four Hundred Twenty-Three Dollars (\$1,030,423) from the City of Long Beach
17 for design, construction, construction engineering and inspection and project
18 admin/management/etc. costs.

19 3. CITY OF COMPTON'S RESPONSIBILITIES. Compton shall:

20 A. Deposit One Hundred Thirty-One Thousand Three Hundred
21 Thirty-Six Dollars (\$131,336) with the City of Long Beach for this Project within
22 thirty (30) days of the execution of this Agreement;

23 B. Provide no-cost permits for Project activities in the public
24 right-of-way;

25 C. Provide as-needed technical assistance.

26 4. CITY OF LONG BEACH'S RESPONSIBILITIES. Long Beach shall:

27 A. Pay one hundred percent (100%) of the cost of the Project,
28 estimated not to exceed One Million One Hundred Sixty-One Thousand Seven

1 Hundred Fifty-Nine Dollars (\$1,161,759.00);

2 B. Assume responsibility for all procurement activities, including
3 the preparation of plans and specifications, cost estimates and all Project
4 construction documents;

5 C. Award the contract for construction of the Project as required
6 by applicable law to a contractor. Contractor's insurance shall name the City of
7 Compton as additional insured;

8 D. Provide or select appropriate construction engineering and
9 inspection services;

10 E. Hold weekly Project meetings with the selected contractor as
11 required;

12 F. Upon Project completion, provide as-built plans to the City of
13 Compton.

14 5. FINAL ACCOUNTING; REFUND OR ADDITIONAL
15 CONTRIBUTION. Within one hundred twenty (120) calendar days after final acceptance
16 of the Project, the City of Long Beach shall cause a final accounting to be prepared and
17 delivered to the City of Compton. If Project costs within the City of Compton exceed its
18 \$131,336 deposit, the City of Compton shall pay its remaining balance to the City of Long
19 Beach within sixty (60) calendar days. If Project costs within the City of Compton are
20 less than its \$131,336 deposit, the City of Long Beach shall pay the remaining balance to
21 the City of Compton within sixty (60) calendar days.

22 6. INDEMNIFICATION.

23 A. Pursuant to Government Code Section 895.4, the City of
24 Compton shall indemnify, defend and hold the City of Long Beach harmless from
25 any liability imposed for injury (as defined by Government Code Section 810.8)
26 occurring by reason of any acts or omissions on the part of the City of Compton
27 under or in connection with any work, authority or jurisdiction delegated to the City
28 of Compton under this Agreement.

OFFICE OF THE CITY ATTORNEY
CHARLES PARKIN, City Attorney
333 West Ocean Boulevard, 11th Floor
Long Beach, CA 90802-4664

1 B. The City of Long Beach shall indemnify, defend and hold the
2 City of Compton harmless from any liability imposed for injury (as defined by
3 Government Code Section 810.8) occurring by reason of any acts or omissions on
4 the part of the City of Long Beach under or in connection with any work, authority
5 or jurisdiction delegated to the City of Long Beach under this Agreement

6 7. NON-LIABILITY OF CITY OFFICERS AND EMPLOYEES.

7 A. No officer or employee of the City of Long Beach shall be
8 personally liable to the City of Compton in the event of any default or breach by
9 the City of Long Beach or for breach of any obligation of the terms of this
10 Agreement.

11 B. No officer or employee of the City of Compton shall be
12 personally liable to the City of Long Beach in the event of any default or breach by
13 the City of Compton or for breach of any obligation of the terms of this Agreement

14 8. NOTICE. Any notice hereunder by either party shall be in writing
15 and personally delivered or deposited in the U.S. Postal Service, first class, postage
16 prepaid, addressed to the City of Long Beach at 333 West Ocean Boulevard, Long
17 Beach, California 90802, Attn: City Manager; and to the City of Compton at 205 South
18 Willowbrook Avenue, Compton, California 90220, Attn: Director, Public Works/Municipal
19 Utilities Department. Notice shall be deemed given on the date deposited in the mail or
20 on the date personal delivery is made, whichever first occurs.

21 9. ENTIRE AGREEMENT. This Agreement constitutes the entire
22 understanding between the parties and supersedes all other agreements, whether oral or
23 written, with respect to the subject matter herein.

24 10. AMENDMENT. This Agreement shall not be amended except in
25 writing signed by the parties that expressly refers to this Agreement.

26 11. TERMINATION. This Agreement shall terminate upon completion
27 and acceptance of the Project, or on APRIL 1st, 2016, whichever is earlier.

28 12. WAIVER. The waiver of any breach of this Agreement shall not be

OFFICE OF THE CITY ATTORNEY
CHARLES PARKIN, City Attorney
333 West Ocean Boulevard, 11th Floor
Long Beach, CA 90802-4664

1 effective unless in writing signed by the party permitting waiver and shall not constitute a
2 waiver of any other or subsequent breach of this Agreement.

3 13. GOVERNING LAW. This Agreement shall be governed by and
4 construed in accordance with the laws of the State of California (except those provisions
5 of California law pertaining to conflicts of laws).

6 14. THIRD PARTY BENEFICIARY. This Agreement is not intended or
7 designed to or entered for the purpose of creating any benefit or right for any person or
8 entity of any kind that is not a party to this Agreement.

9 ///

10 ///

11 ///

12 ///

13 ///

14 ///

15 ///

16 ///

17 ///

18 ///

19 ///

20 ///

21 ///

22 ///

23 ///

24 ///

25 ///

26 ///

27 ///

28 ///

1
2
3
4
5
6
7
8
9
10
11
12
13
14
15
16
17
18
19
20
21
22
23
24
25
26
27
28

IN WITNESS WHEREOF, the parties have caused this document to be duly executed with all formalities required by law as of the date first stated above.

CITY OF LONG BEACH, a municipal corporation

March 10, 2014
2015

By [Signature]
City Manager
Assistant City Manager

EXECUTED PURSUANT TO SECTION 301 OF THE CITY CHARTER.

This Agreement is approved as to form on 2/24, 2014. 15

CHARLES PARKIN, City Attorney

By [Signature]
Deputy

CITY OF COMPTON

1/8/15, 2014

By [Signature]
City Manager

Approved as to form:

By [Signature] (1/8/15)
Craig J. Cornwell, City Attorney

ATTEST

By [Signature] 1-12-15
Alita Godwin, City Clerk

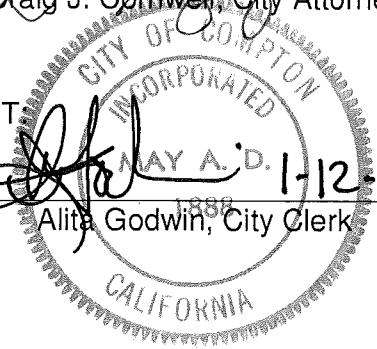

OFFICE OF THE CITY ATTORNEY
CHARLES PARKIN, City Attorney
333 West Ocean Boulevard, 11th Floor
Long Beach, CA 90802-4664

MATCHLINE STATION 26+00 FOR CONTINUATION SEE ABOVE RIGHT

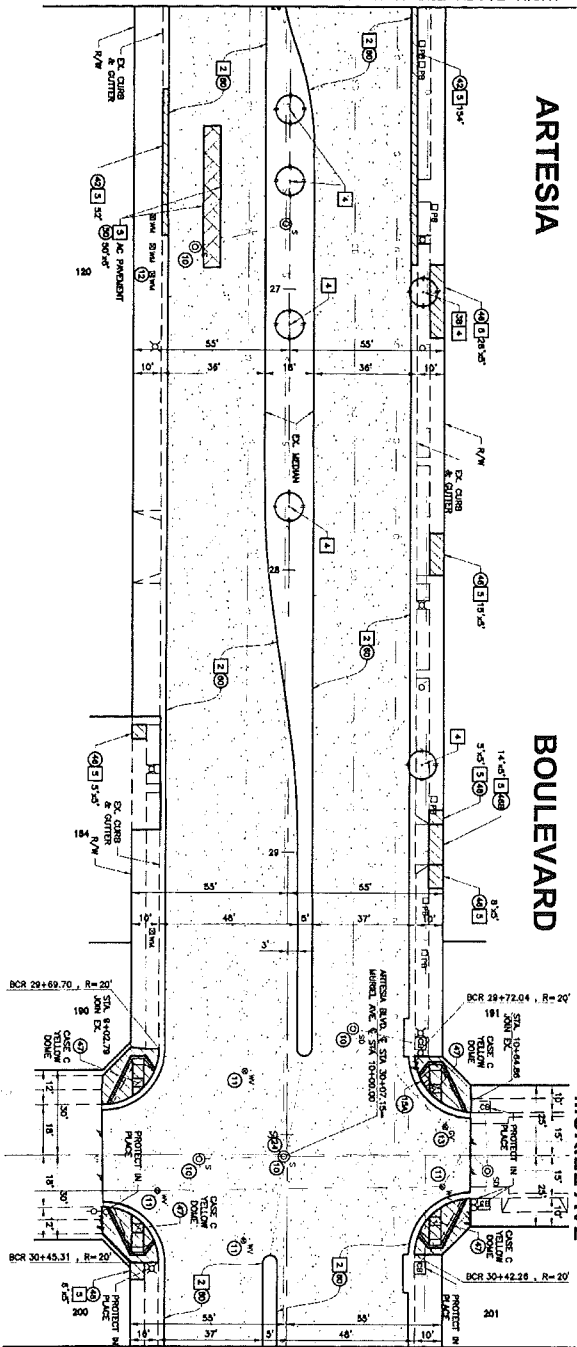

MATCHLINE STATION 20+00 FOR CONTINUATION SEE SHEET 3

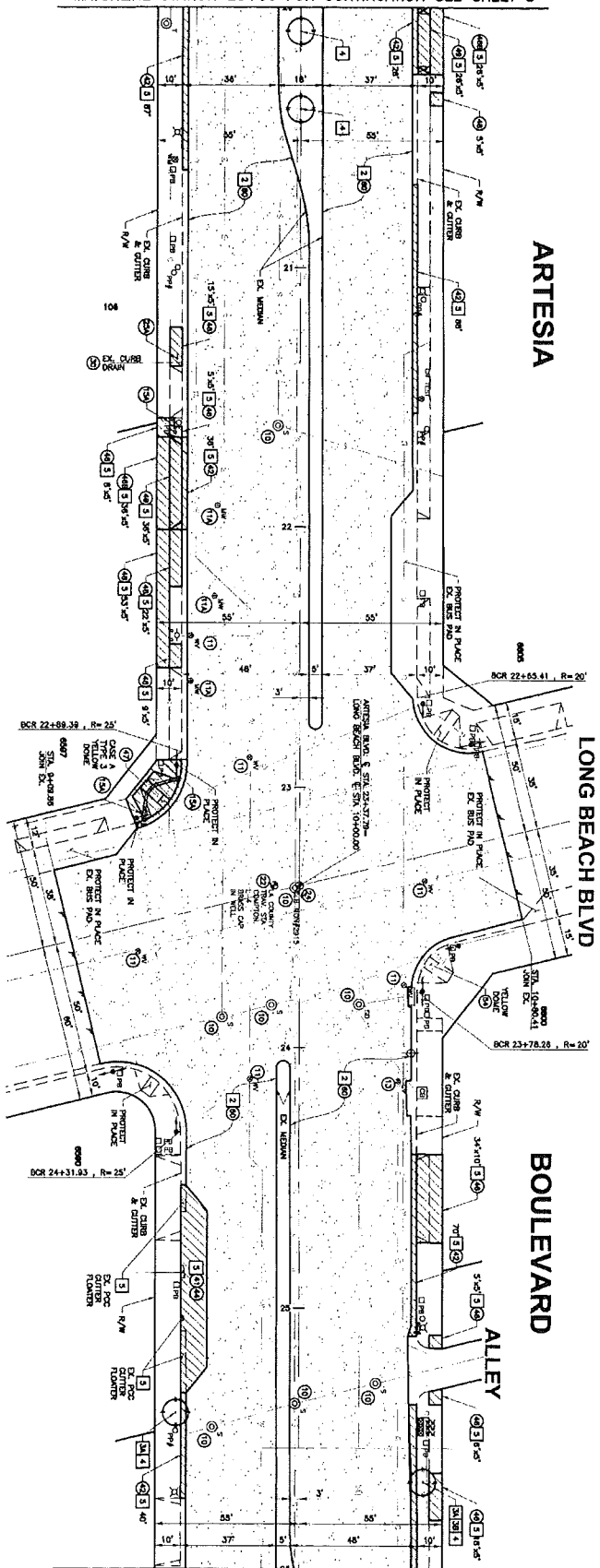

FINAL SUBMITTAL

1/2/17

12/5/17

SCALE: 1" = 20'

NO. 4: 0974

SHEET 4 OF 9

DATE: 12/5/17

PROJECT: ARTESIA BOULEVARD BETWEEN PT WILONG BEACH BLVD AND PT EMURIEL AVE CONSTRUCTION PLAN

FIG 2 ROCK

PAGE

DRAWING NO: C-5004

**ARTESIA BOULEVARD BETWEEN
 PT WILONG BEACH BLVD AND PT EMURIEL AVE
 CONSTRUCTION PLAN**

DESIGNED BY:	REVISIONS	DESCRIPTION
LIS & VMAC	No. DATE SHEET APPROVAL	
DRAWN BY:		
VMAC / AA		
DESIGN CHECK BY:		
GED		
DRAWING CHECK BY:	AS-BUILT:	REF. C-3707, C-5322, C-5366, C-5629, F38, G38, 08-4127, 08-4128, 08-4047
GED		

MATCHLINE STATION 36+75 FOR CONTINUATION SEE ABOVE RIGHT

MATCHLINE STATION 30+75 FOR CONTINUATION SEE SHEET 4

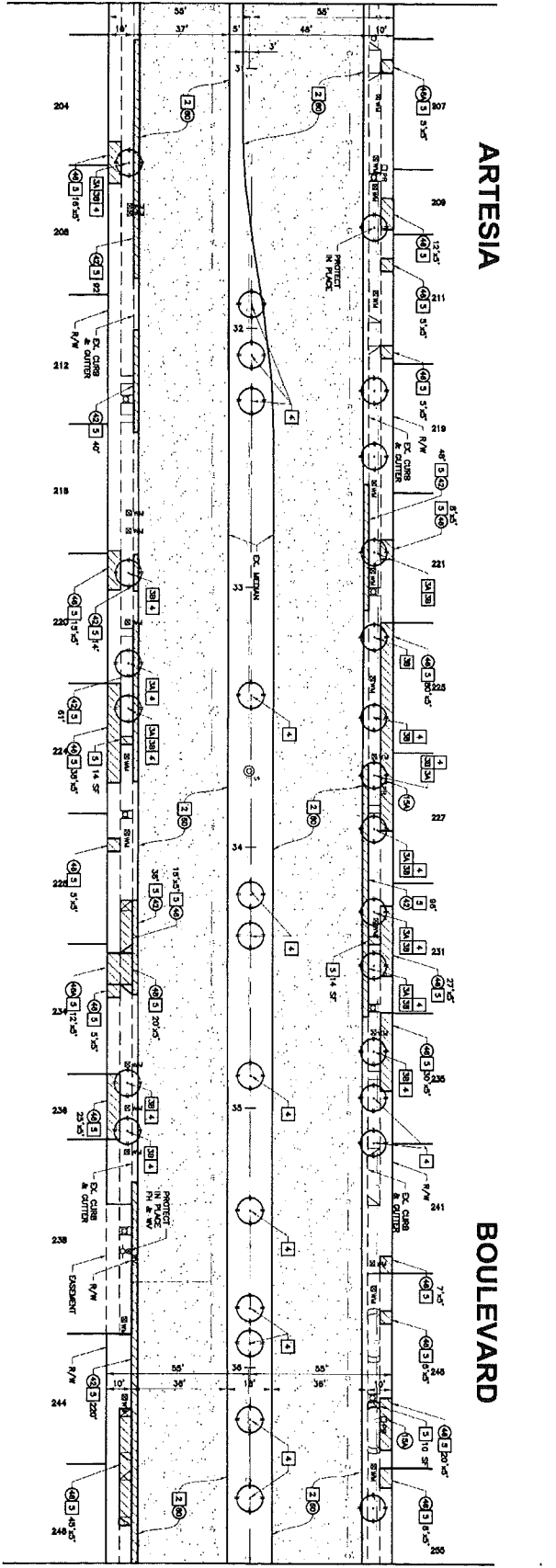
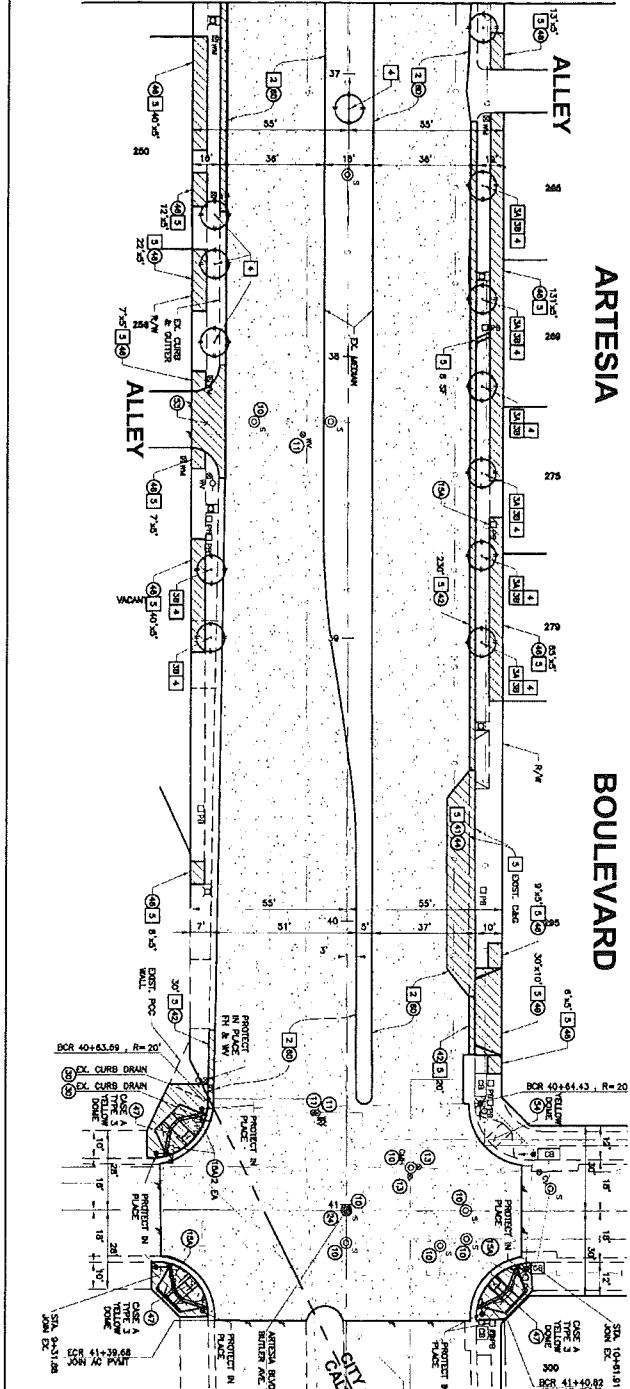

MATCHLINE STATION 36+75 FOR CONTINUATION SEE BELOW LEFT

FINAL SUBMITTAL

DATE: 12/13/13

PROJECT: ARTESIA BOULEVARD IMPROVEMENTS

SCALE: 1"=20'

NO. 10-4181-11

DATE: 12/13/13

PROJECT: ARTESIA BOULEVARD IMPROVEMENTS

DATE: 12/13/13

PROJECT: ARTESIA BOULEVARD IMPROVEMENTS

DATE: 12/13/13

PROJECT: ARTESIA BOULEVARD IMPROVEMENTS

DATE: 12/13/13

**ARTESIA BOULEVARD BETWEEN
 PT E/MURIEL AVE AND PT E/BUTLER AVE
 CONSTRUCTION PLAN**

NO. 10-4181-11

DATE: 12/13/13

PROJECT: ARTESIA BOULEVARD IMPROVEMENTS

DATE: 12/13/13

PROJECT: ARTESIA BOULEVARD IMPROVEMENTS

DATE: 12/13/13

PROJECT: ARTESIA BOULEVARD IMPROVEMENTS

DATE: 12/13/13

DESIGNED BY:	REVISIONS	DESCRIPTION
US & W	NO. DATE SHEET APPROVAL	
DAVID BY:		
VMC / AA		
DESIGN CHECK BY:		
DEB		
DRAWING CHECK BY:	AS-BUILT	REF: C-3707, C-5322, C-5366, C-5629, F34, G36, OB-4127, OB-4128, OB-4047
DEB		

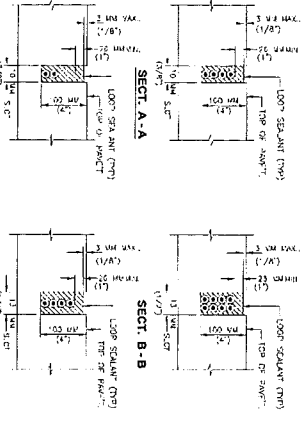
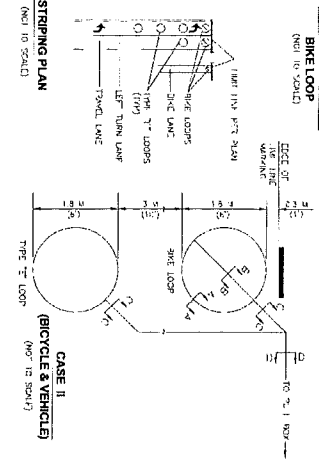
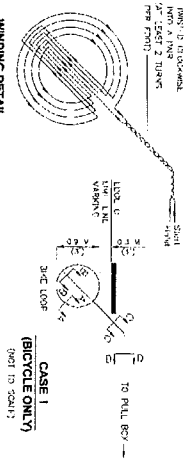

- NOTES:
1. LOOPING SHALL BE CORRECTED IN JUNCTS.
 2. DEPTH OF SAW SLOT SHALL NOT EXCEED DEPTH OF PAVENT.
 3. WIDTH OF SAW SLOT SHALL BE SMOOTH WITH NO CHISEL EDGES.
 4. SECTIONS SHALL BE SHOWN WITH CHAIN, BOUNDARY AND "HORIZONTAL" DEFS.
 5. BEFORE INSTALLING LOOP CONDUCTORS:
 6. VERIFY THAT ALL EXISTING UTILITY LINES ARE PROTECTED.
 7. VERIFY THAT ALL EXISTING UTILITY LINES ARE PROTECTED.
 8. VERIFY THAT ALL EXISTING UTILITY LINES ARE PROTECTED.
 9. VERIFY THAT ALL EXISTING UTILITY LINES ARE PROTECTED.
 10. VERIFY THAT ALL EXISTING UTILITY LINES ARE PROTECTED.

1
6/9

2
6/9

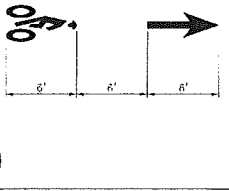

GENERAL STRIPING NOTES

1. ALL MARKINGS & STRIPING SHALL BE THERMOPLASTIC.
2. COLORED CURB ZONES SHALL BE REMOVED AND/OR REPAIRED INSTANTLY AS FOLLOWS:
 (a) **RED** INDICATES PAINT CURB RED. LENGTH AS NOTED PER PLAN (4.9-307).
 (b) **GREEN** INDICATES PAINT CURB GREEN. LENGTH & TIME LIMIT AS NOTED PER PLAN (4.9-207 LONG & TIME LIMIT OF 30 MINUTES).
 (c) **WHITE** INDICATES PAINT CURB WHITE. LENGTH AS NOTED PER PLAN (4.9-207).
 (d) **BLUE** INDICATES PAINT CURB BLUE. LENGTH AS NOTED PER PLAN (4.9-207).
3. CONTRACTOR SHALL VERIFY IN FIELD AND REPLACE IN KIND ALL COLORED CURB ZONES AS DIRECTED BY THE ENGINEER.
4. INDICATES BICYCLE LOOP DETECTOR.
5. (TYP) INDICATES THAT SHOWN CONSTRUCTION ITEMS SHALL OCCUR AS SHOWN ON OTHER PAGES OF THE PLANS TYPICALLY.
6. THE CONTRACTOR SHALL REVIEW THE CONSTRUCTION DRAWINGS THOROUGHLY. OMISSION AND/OR DISCREPANCY BEFORE START OF ANY CONSTRUCTION.
7. ALL EXISTING PAVEMENT MARKINGS, MARKERS AND STRIPING CONFLICTING WITH AND/OR UNLESS PROPOSED MARKINGS, MARKERS AND STRIPING SHALL BE REMOVED COMPLETELY BY WET GRINDING OR WET SANDBLASTING, AND THEN REPAIRED TO A FINISH AND CURB CORNER NO NEW MARKINGS/STRIPING SHALL BE APPLIED OVER ANY EXISTING MARKINGS/STRIPING.

STRIPING & SIGNING CONSTRUCTION NOTES (FOR STRIPING & SIGNING PLAN)

- (80) INSTALL 12" CROSSWALK MARKING, COLOR AS NOTED ON PLAN, PER C&B STANDARD PLAN No. 307.
- (81) INSTALL ARROW PAVEMENT MARKING/ARROW, TYPE AND COLOR AS NOTED ON PLAN, PER CALTRANS STANDARD AND C&B STANDARD PLAN No. 308.
- (82) INSTALL WHITE STOP LETTERS AND LIGHT BLUE MARKERS PER C&B STANDARD PLAN No. 309.
- (83) INSTALL 50-FOOT WHITE LINE STRIPING WITH TYPE C MARKER AT EITHER END.
- (84) INSTALL 50-FOOT YELLOW CENTERLINE STRIPING WITH TYPE D MARKER AT EITHER END.
- (85) INSTALL STRIPING (WITH BASED PAVEMENT MARKERS AS REQUIRED). DETAIL AS NOTED, PER PLAN AND CALTRANS STANDARD PLAN 404-400.
- (86) INSTALL WHITE BINE LINE ARROW AND BINE LINE SYMBOL, PER CALTRANS STANDARD PLAN 204 AND 205 AND DETAIL (S19) THIS SHEET.
- (87) INSTALL TYPE "T" INDUCTIVE LOOP DETECTOR PER CALTRANS STD PLAN ES-55.
- (88) INSTALL BIPOLE/VEHICLE INDUCTIVE LOOP DETECTOR PER DETAIL (S19) THIS SHEET.

FINAL SUBMITTAL

1/25/13
 1/25/13
 1/25/13

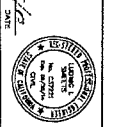

NO. 1 REV. 9
 DATE: 12/13/13
 DRAWN BY: VMC / AA
 CHECKED BY: GEC
 DATE: 12/13/13

ARTESIA BOULEVARD BETWEEN WEST CITY LIMIT AND BUTLER AVE STRIPING NOTES AND DETAILS

FIELD BOOK PAGE GRAPHIC SCALE 0 1 2 3

REVISIONS	APPROVAL	DESCRIPTION
NO.	DATE	SHEET

DESIGNED BY: SM & S
 DRAWN BY: VMC / AA
 CHECKED BY: GEC
 DRAFTING CHECK BY: GEC

AS-BUILT: R.F. C-3707, C-5322, C-5364, C-5429, F3A, G3A, 08-4127, 08-4128, 08-4047

DATE: 12/13/13
 DRAWN BY: VMC / AA
 CHECKED BY: GEC
 DATE: 12/13/13

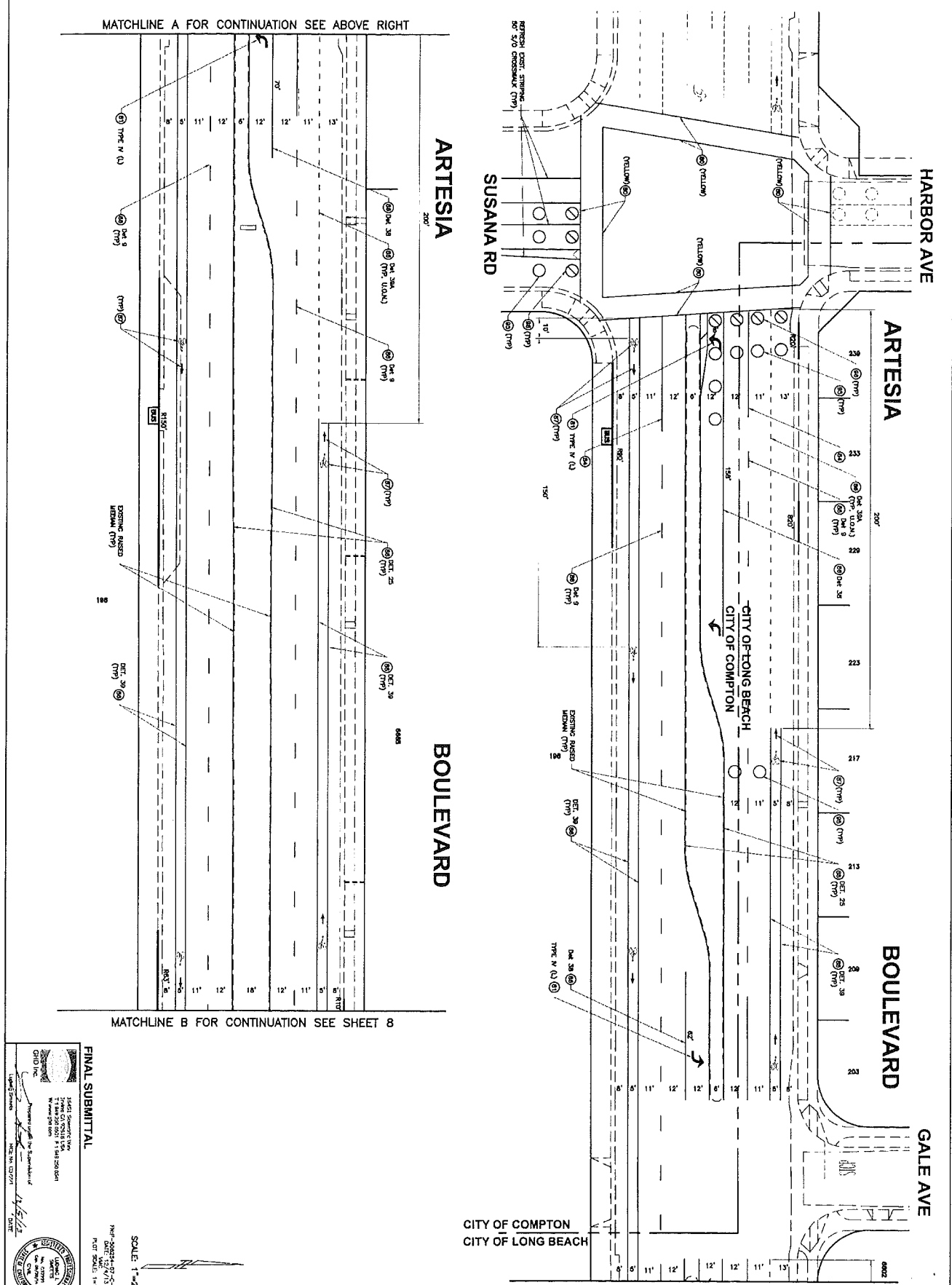

FINAL SUBMITTAL

15421 S. Harbor Ave
 City of Compton
 90220-1000
 310-638-1000
 310-638-1001
 310-638-1002
 310-638-1003
 310-638-1004
 310-638-1005
 310-638-1006
 310-638-1007
 310-638-1008
 310-638-1009
 310-638-1010
 310-638-1011
 310-638-1012
 310-638-1013
 310-638-1014
 310-638-1015
 310-638-1016
 310-638-1017
 310-638-1018
 310-638-1019
 310-638-1020

SCALE: 1"=20'

DATE: 11/5/17

ARTESIA BOULEVARD BETWEEN HARBOR AVE AND PT W/LONG BEACH BLVD SIGNING AND STRIPING PLAN

NO. 17-0074
 SHEET 7 OF 9
 DRAWING NO. C-8004

DESIGNED BY	REVISIONS	DATE	SHEET	APPROVAL	DESCRIPTION
LIS & YMC					
YMC / AA					
DESIGN CHECK BY					
CEB					
DRAWING CHECK BY					
CEB					

REF: C-3707, C-8322, C-8366, C-8629, F38, C38, 08-4127, 08-4128, 08-4047

MATCHLINE C FOR CONTINUATION SEE ABOVE RIGHT

MATCHLINE B FOR CONTINUATION SEE SHEET 7

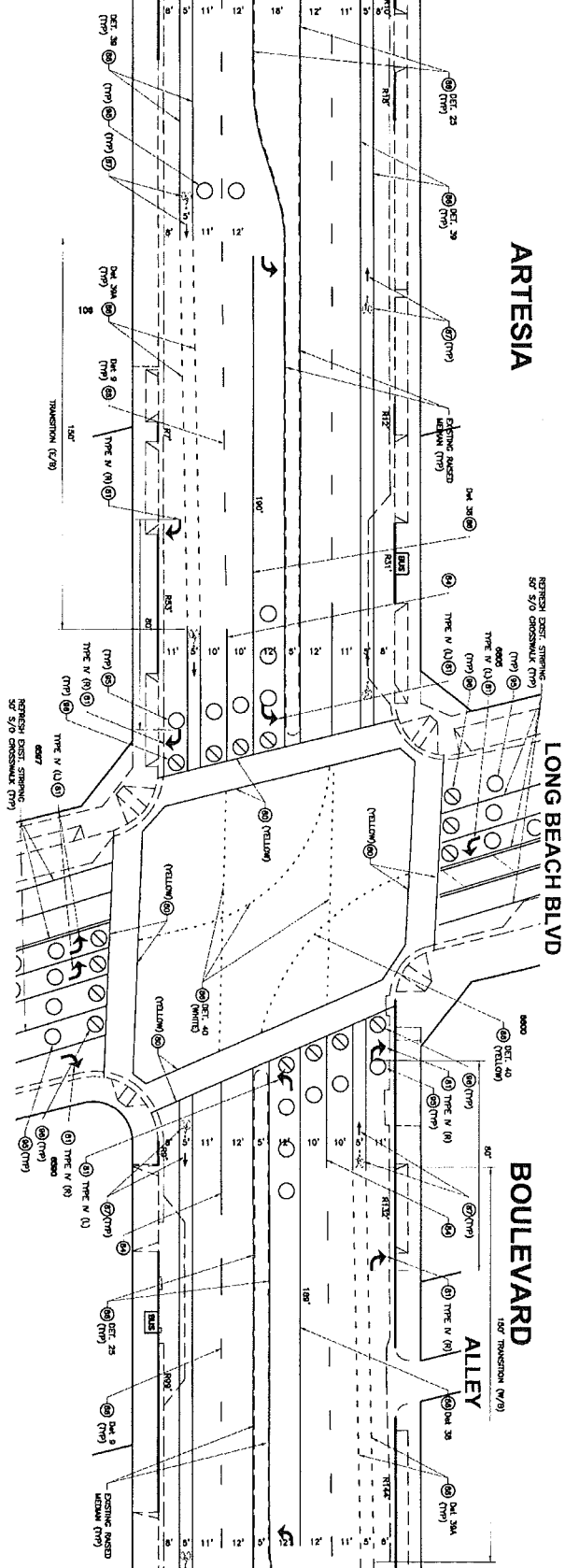
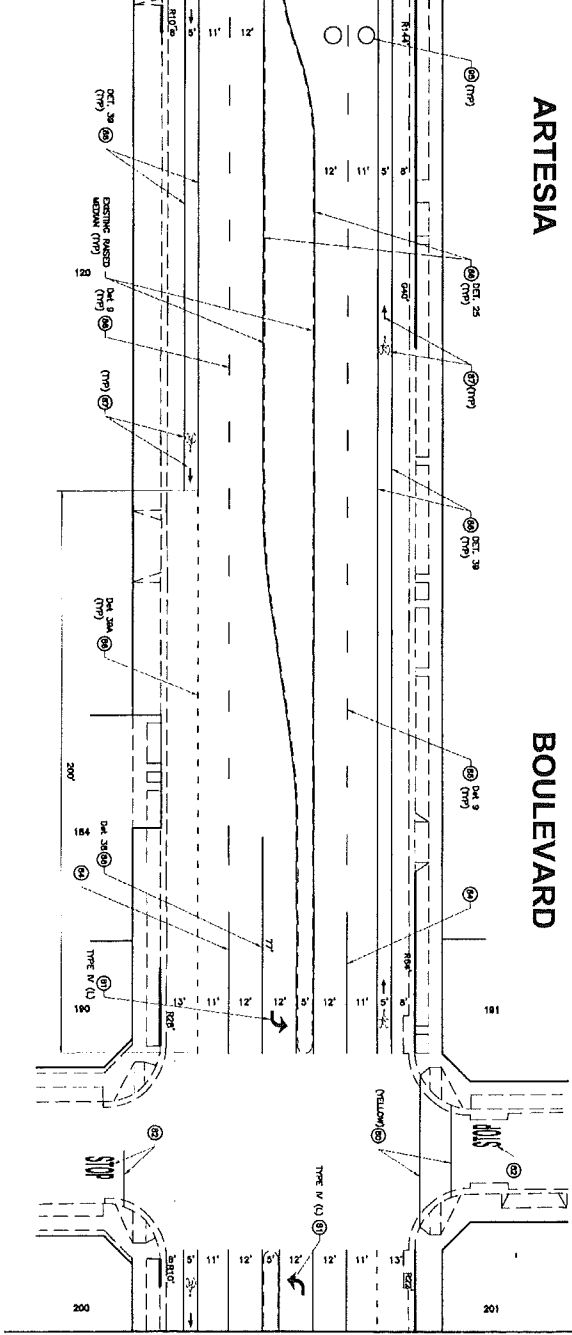

MATCHLINE D FOR CONTINUATION SEE SHEET 9

MATCHLINE C FOR CONTINUATION SEE BELOW LEFT

FINAL SUBMITTAL

15415 Seward Ave
 11800 200th St #180202, Oak
 Walnut Creek, CA 94598
 (925) 938-1100
 Fax: (925) 938-1101
 www.ghdinc.com
 GHD Inc.
 Prepared by: [Signature]
 Checked by: [Signature]
 Date: 12/13/13
 Date: 12/13/13

SCALE: 1" = 40'
 DATE: 12/13/13
 PLOT SCALE: 1" = 1"

NO. IN SET	8
JOB NO.	100000000-04
DATE	12/13/13
PROJECT	ARTESIA BOULEVARD
DRAWING NO.	C-5004

**ARTESIA BOULEVARD BETWEEN
 PT W/ LONG BEACH BLVD AND PT E/ MURIEL AVE
 SIGNING AND STRIPING PLAN**

DESIGNED BY:	REVISED	DESCRIPTION
LSB & MRC	No	
DATE	DATE	
SHEET	SHEET	
APPROVAL	APPROVAL	
DESIGNED BY:		
YMC / AA		
LESSON CHECK BY:		
DEC		
DRAFTING CHECK BY:	AS-BUILT:	
DEC		

REF. C-3707, C-5322, C-5356, C-5829, F36, 036,
 08-4127, 08-4126, 08-4047

Exhibit "B"

PROJECT BUDGET

Item Description	City of Compton	City of Long Beach	Total Budget
Estimated Construction Cost	\$ 94,913	\$ 744,660	\$ 839,573
Construction Contingency (15%)	\$ 14,237	\$ 111,699	\$ 125,936
Design Services (10%)	\$ 9,491	\$ 74,466	\$ 83,957
Const. Engrt., Const. Inspect., Project Mgmt. & Admin. (10%)	\$ 9,491	\$ 74,466	\$ 83,957
Subtotal	\$ 128,132	\$ 1,005,291	\$ 1,133,423
Overhead & Administration (2.5%)	\$ 3,203	\$ 25,132	\$ 28,336
Budget Total	\$ 131,336	\$ 1,030,423	\$ 1,161,759

RESOLUTION NO. 24,051

1 A RESOLUTION OF THE CITY COUNCIL OF THE CITY OF COMPTON
2 AUTHORIZING THE CITY MANAGER TO ENTER INTO A COOPERATIVE
3 AGREEMENT WITH THE CITY OF LONG BEACH, INCLUDING ANY
4 NECESSARY AMENDMENTS THERETO, FOR DESIGN, CONSTRUCTION
5 ENGINEERING AND INSPECTION, PROJECT MANAGEMENT AND
6 ADMINISTRATION OF THE STREET REHABILITATION PROJECT FOR
7 ARTESIA BOULEVARD, FOR AN ESTIMATED TOTAL CONTRACT AMOUNT
8 OF \$131,336

9
10 **WHEREAS**, the street infrastructure on Artesia Boulevard between City of Long
11 Beach's west city limit and Butler Avenue is in need of rehabilitation. Plans and
12 Specifications No. R-6974 and cost estimate for the Improvement of Artesia Boulevard
13 were prepared by the City of Long Beach; and

14
15 **WHEREAS**, the Artesia Boulevard rehabilitation work consists primarily of
16 pavement crack filling, milling and street resurfacing; replacing damaged
17 driveways, sidewalks and curbs; installing bus pads, traffic striping, markings, and
18 markers; traffic control; water quality best management practices; and related
19 improvements. The old asphalt material to be removed under this contract will be
20 recycled into new asphalt concrete, or utilized as base material on other street
21 projects. The street will be resurfaced with asphalt containing up to 15 percent
22 recycled material. Finally, road base made from recycled concrete, rock, sand and
23 asphalt will be utilized in this project and all concrete work will include recycled
24 waste ash, diverting these materials from our landfills; and

25
26 **WHEREAS**, the majority of the Artesia Boulevard Improvement Project is located in
27 the City of Long Beach, however, due to the location of the Long Beach/Compton city
28 boundary in the vicinity of the Artesia Boulevard intersection with Susana Road/Harbor
29 Avenue, work within the City Compton was included in the project to facilitate pavement
30 rehabilitation work and minimize public inconvenience; and

31
32 **WHEREAS**, according to City of Long Beach staff, the project was certified as
categorically exempt in 2013, thus no further action is required to comply with the
California Environmental Quality Act (CEQA); and

WHEREAS, this project was advertised in the Press-Telegram on April 25, 2014,
and four (4) bids were received on May 28, 2014; to wit: Sully Miller Contracting (Brea) in
the amount of \$839,572.63, All American Asphalt (Corona) in the amount of \$899,690.20,
Griffith Company (Santa Fe Springs) in the amount of \$919,820.68 and Excel Paving
(Long Beach) in the amount of \$899,227.83. After review of the bids by the Long Beach
City Attorney's Office and the Budget Analysis Officer, it was determined by Long Beach
staff that Sully Miller Contracting was the lowest responsible bidder; and

WHEREAS, on July 22, 2014, the Long Beach City Council approved this project
And authorized their City Manager to award the construction improvement contract to
Sully Miller Contracting and enter into a Cooperative Agreement with the City of Compton
for the prorated share of costs for the project; and

WHEREAS, joining with the City of Long Beach is sharing the costs of this project
will facilitate pavement rehabilitation work, minimize public inconvenience and save City
staff resources and funds that would need to be expended if the City of Compton were to
procure rehabilitation of Artesia Boulevard within Compton boundaries on its own; and

WHEREAS, funds in the amount of \$131,336 are available in the Public Works
Fiscal Year 2014-2015 budget [Prop C], Account No. 1900-710-000-4269; and

WHEREAS, staff recommends the City Council approve the joint project with the
City of Long Beach.

NOW, THEREFORE, THE CITY COUNCIL OF THE CITY OF COMPTON DOES HEREBY RESOLVE AS FOLLOWS:

Section 1. That the City Manager is hereby authorized to enter into a Cooperative Agreement with the City of Long Beach and deposit with the City of Long Beach, in an amount not to exceed \$131,336.00, to improve Artesia Boulevard within the City of Compton limits.

Section 2. That funds in the amount of \$131,336 are available in the Public Works Fiscal Year 2014-2015 budget [Prop C], Account No. 1900-710-000-4269.

Section 3. That copies of this Resolution shall be filed in the offices of the City Manager, City Controller, City Clerk, City Attorney and the Public Works/Municipal Utilities Department.

Section 4. That the Mayor shall sign and the City Clerk shall attest to the adoption of this Resolution.

ADOPTED this 2nd day of December, 2014.

[Signature]
MAYOR OF THE CITY OF COMPTON

ATTEST:

CITY CLERK OF THE CITY OF COMPTON

STATE OF CALIFORNIA
COUNTY OF LOS ANGELES
CITY OF COMPTON: ss

[Signature]
CHIEF DEPUTY CITY CLERK

I, Alita Godwin, City Clerk of the City of Compton, hereby certify that the foregoing Resolution was adopted by the City Council, signed by the Mayor, and attested by the City Clerk at a regular meeting thereof held on the 2nd day of December, 2014.

That said Resolution was adopted by the following vote to wit:

AYES: COUNCIL MEMBERS- Zurita, Arceneaux, Jones, Brown
NOES: COUNCIL MEMBERS- None
ABSENT: COUNCIL MEMBERS- Galvan
ABSTAIN: COUNCIL MEMBERS- None

CITY CLERK OF THE CITY OF COMPTON

[Signature]
CHIEF DEPUTY CITY CLERK